

VHM-P Variable Height Arm with Suspension/Dual Display Front-End Operation Guide

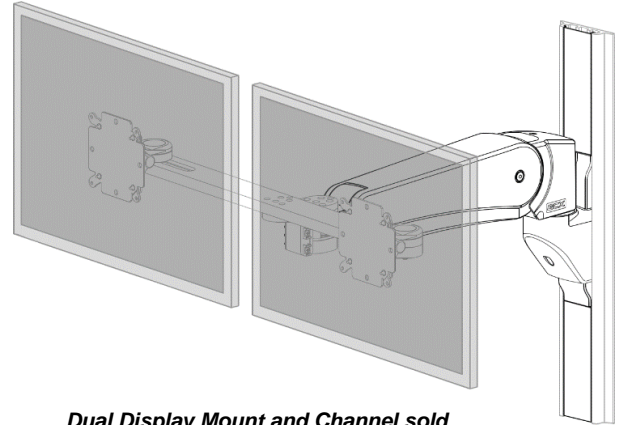

Dual Display Mount and Channel sold separately – Shown for reference only

Safety Labels Locations (VHM-P Series Arms)

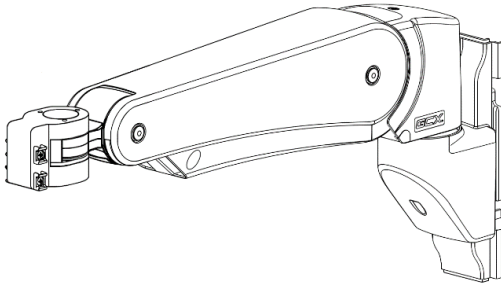
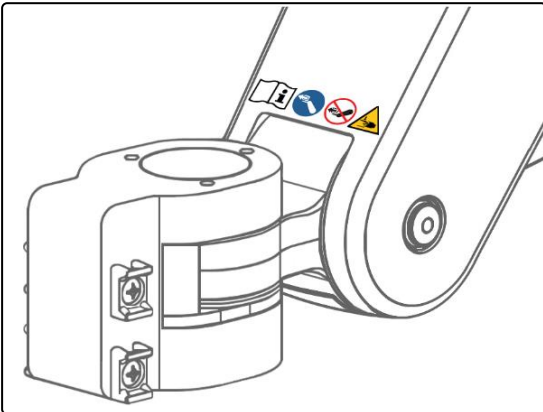

Refer to Installation Guide for additional information.



Remove the Device only when the Arm is at the highest position.



Do not remove device when arm is in a lowered position.



Potential pinch points that may cause personal injury.

Counter Balance Load Range:
25 - 45 lbs / 11.3 - 20.4 kg
or
15 - 30 lbs / 6.8 - 13.6 kg

