

VHM-P (Non-Locking) Variable Height Arm with 8"/20.3cm or 14"/35.6cm Extension and VESA® Mounting Plate for 75 x 75mm or 100 x 100mm applications
Operation Guide

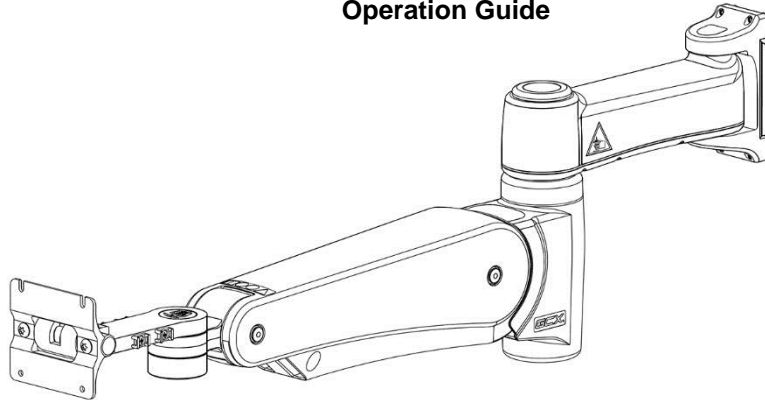

Safety Label Locations (VHM-P Series Arms)

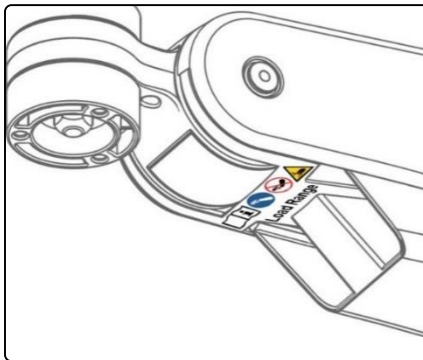
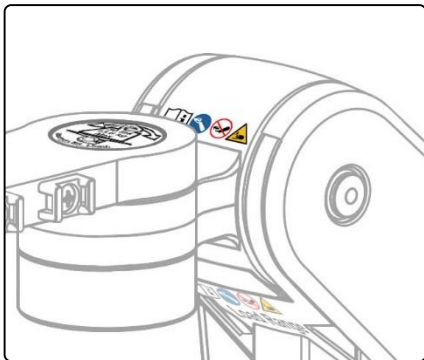

Refer to Installation Guide for additional information.



Remove the Device only when the Arm is at the highest position.



Do not remove device when arm is in a lowered position.



Potential pinch point that may cause personal injury.



Maximum weight for mounting plate with tilt function.

Counter Balance Load Range:
25 - 45 lb / 11.3 - 20.4 kg
or
15 - 30 lb / 6.8 - 13.6 kg

VHM-P (non-locking only)

