

Operation Guide
VHM-PL (Locking) Variable Height Arm (Slide Below-Arm Configuration)
with Slide-In Mounting Plate

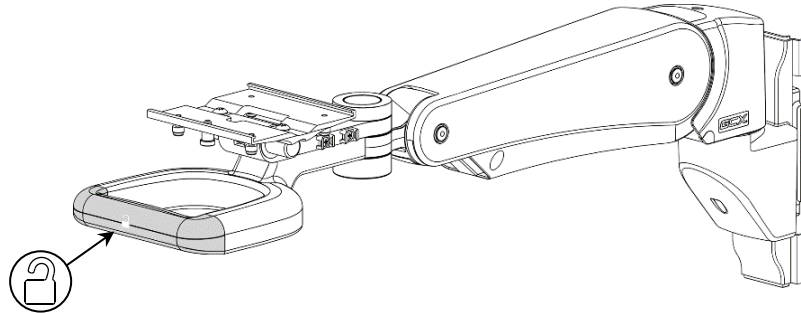

Safety Label Locations

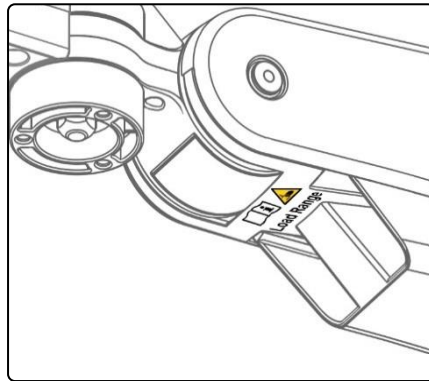
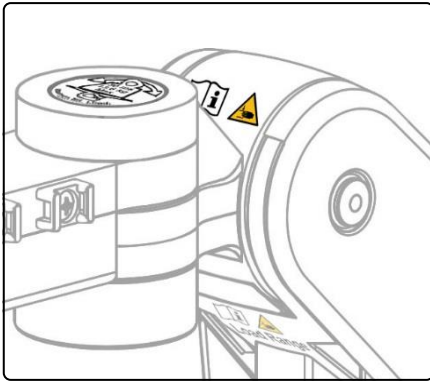

Refer to Installation Guide for additional information.



Potential pinch point that may cause personal injury.



Maximum weight for mounting plate with tilt function.

Counter Balance Load Range:
20 - 45 lb / 9.1 - 20.4 Kg
or
11 - 30 lb / 5.0 - 13.6 Kg

