

Installation Guide

Channel Mount Cross Bar with Dual VHM-25 Arms (Refer to qualified personnel)

Purpose: To describe installation of Channel Mount Cross Bar with Dual VHM-25 Arms into GCX Channels.

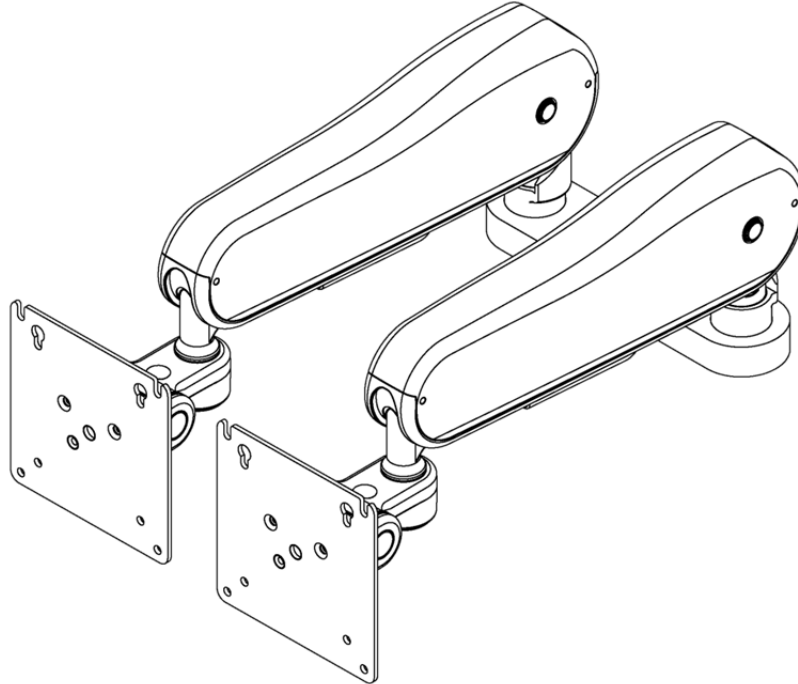

The purpose of this manual is to describe general installation for Channel Mount Cross Bar with Dual VHM-25 Arms. This manual should be used in conjunction with any instrument-specific installation guides used in mounting the monitor or display. Please read this manual and all instrument-specific installation material before installing or using this product.

Parts Reference

The following parts and hardware are included in this installation kit:

Item #	Description	Qty.
1	Channel Mount Cross Bar with Dual VHM-25 Arms	1
2	4" Long Cable Tie	2
3	Adjustable Stop	1

Tools Required:

- 1/8" Hex Wrench (Provided)
- Phillips screwdriver (Not provided)

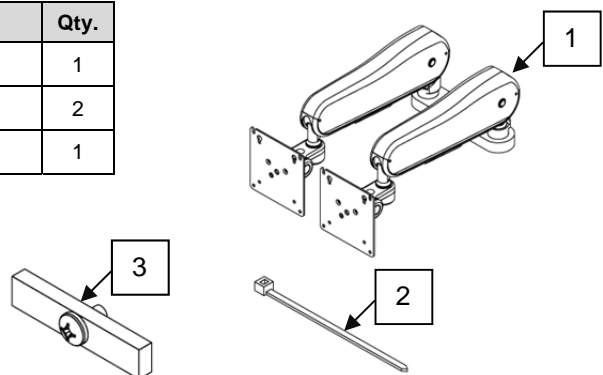

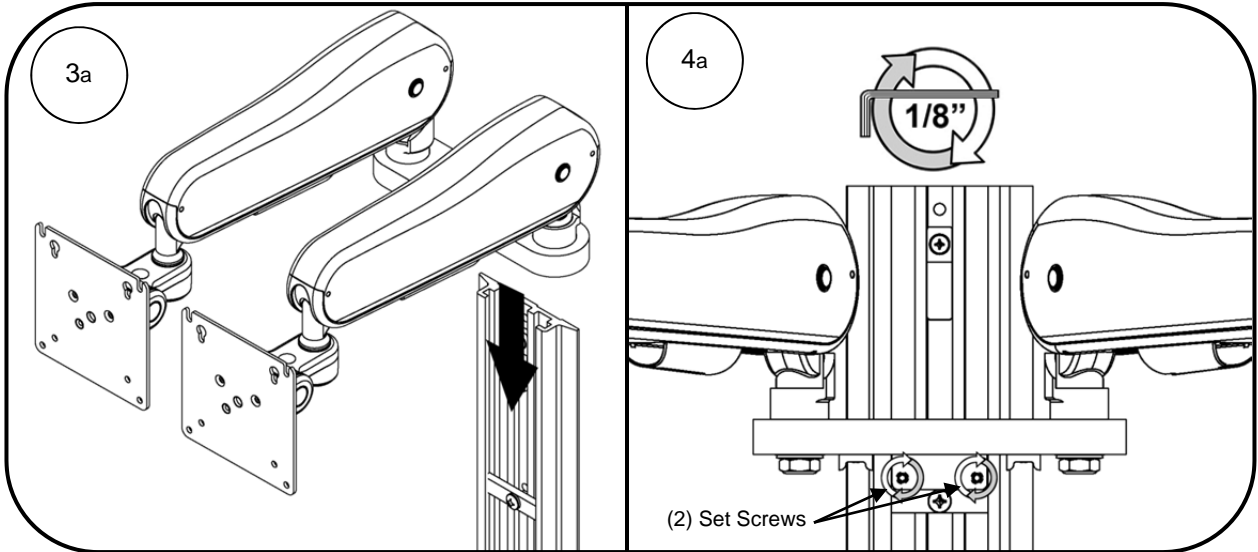
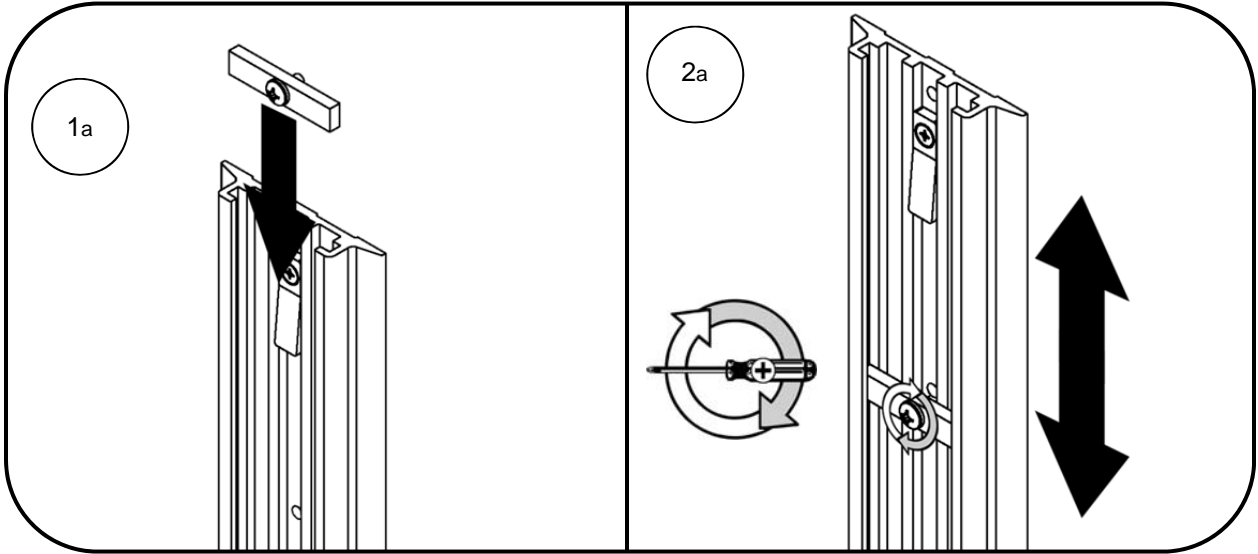

Cable Management

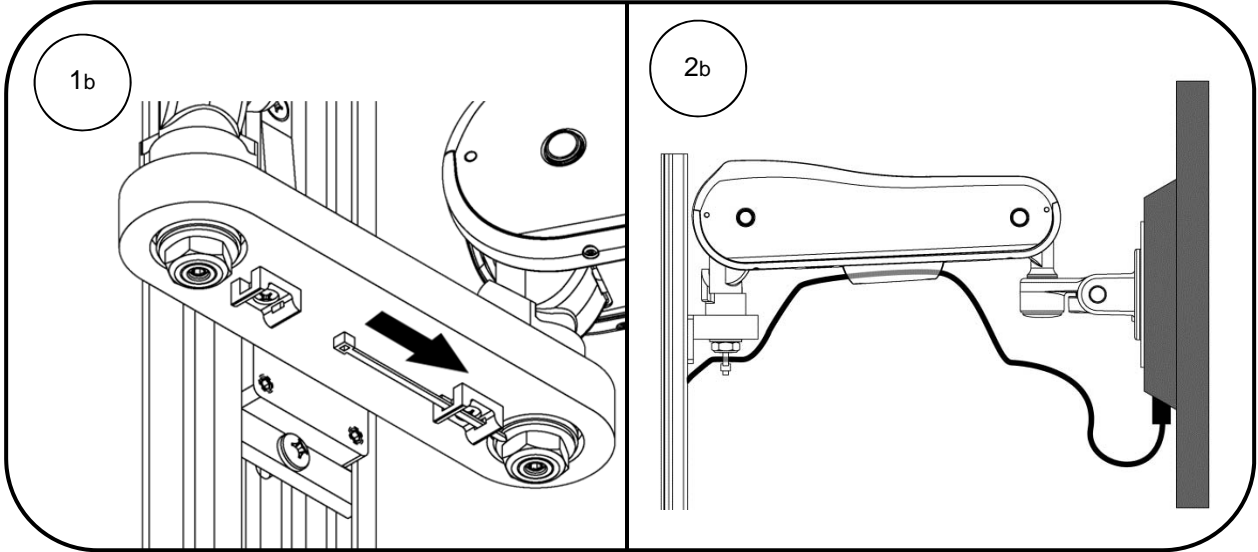

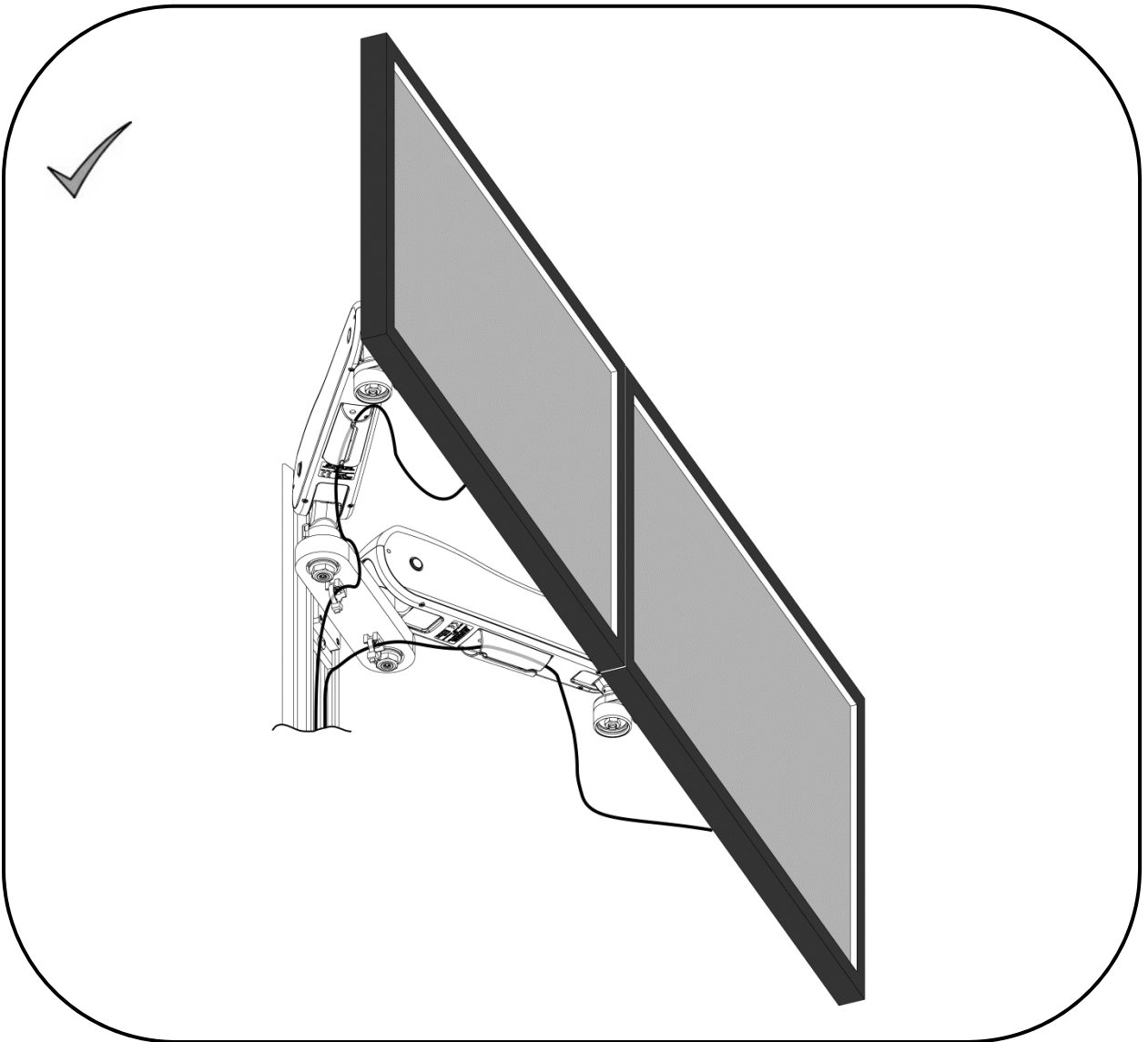
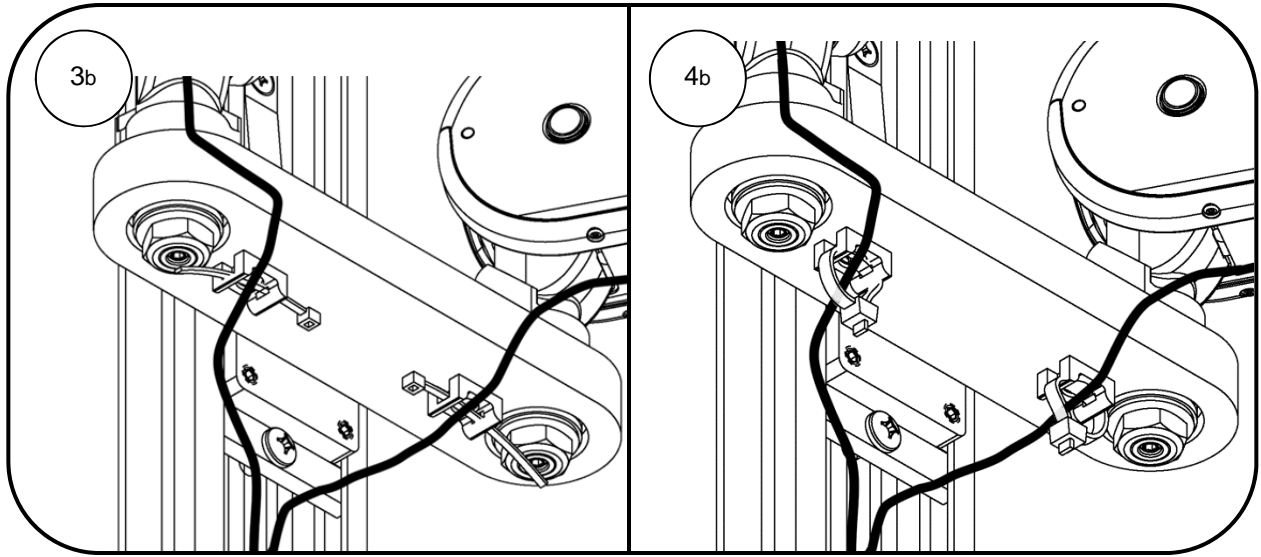

Installation note: This mount is equipped with a stop designed to prevent the arms to rotate for more than 90°, yet it does allow the swivel function on the VESA display mounts.

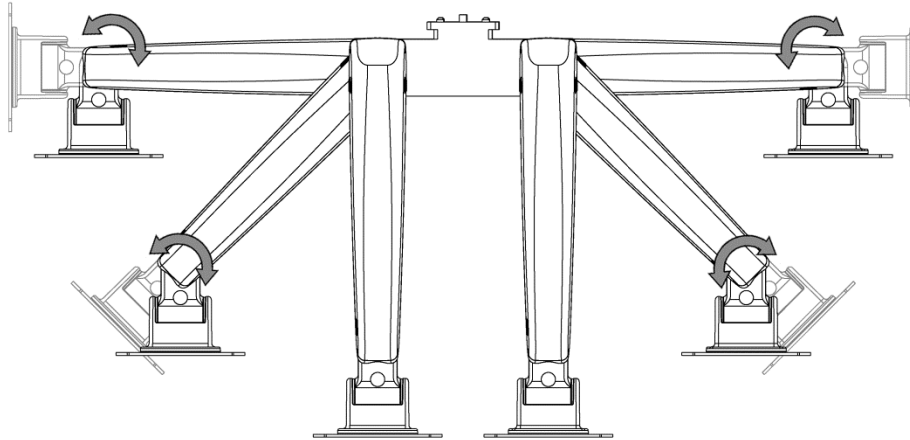

Routine Maintenance

Periodically inspect all fasteners associated with the mounting assembly. Tighten or Adjust as necessary for optimal operation and safety.

Cleaning the Mounting Assembly

The mounting assembly may be cleaned with most mild, non-abrasive solutions commonly used in the hospital environment (e.g. diluted bleach, ammonia, or alcohol solutions).

The surface finish will be permanently damaged by strong chemicals and solvents such as acetone or trichloroethylene.

Steel wool or other abrasive material should never be used.

Damaged caused by the use of unapproved substances or processes will not be warranted. We recommend testing of any cleaning solution on a small area of the mounting assembly that is not visible to verify compatibility.

Never submerge or allow liquids to enter the mounting assembly. Wipe any cleaning agents off the mounting assembly immediately using a water-dampened cloth. Dry the assembly thoroughly after cleaning.

CAUTION: GCX makes no claims regarding the efficacy of the listed chemicals or processes as a means for controlling infection. Consult your hospital's infection control officer or epidemiologist. To clean or sterilize mounted devices or accessory equipment, refer to the specific instructions delivered with those products.