

Installation Guide

Down Post for M Series and VHM Arms

The purpose of this guide is to describe the procedure for attaching down post to Arm.

Parts Reference

The following parts and hardware will be used in this procedure (see photos for parts, hardware not shown):

Item #	Description	Qty
1	Down Post	1
2	10-32 x 3/8" Socket Head Cap Screw (SHCS)	3
3	5/32" Hex Wrench	1



Tools Required: 5/32" hex key (provided).

M Series Arm – Down Post Attachment

1. Remove plastic bolt cap from Swivel Cup (front end of the arm).
2. Using the 5/32" hex wrench provided, fasten Post to Swivel Cup with three (3) 10-32 x 3/8" SHCS as shown below.

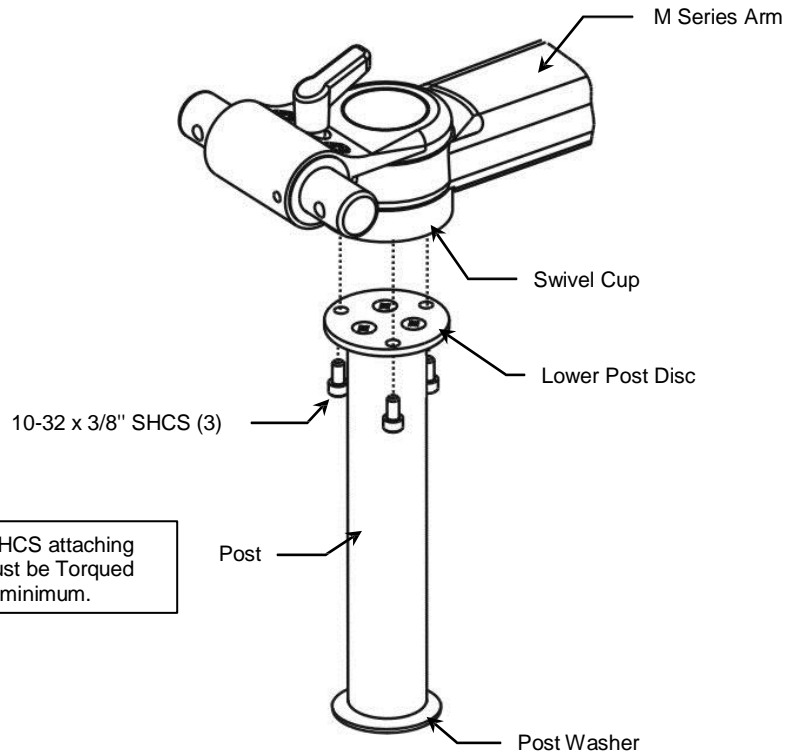
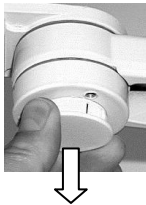

The (3) 10-32 x 3/8" SHCS attaching Post to Swivel Cup must be Torqued to 30 in/lbs (3.39N-m) minimum.

VHM Arm – Down Post Attachment

Installation Note: This installation kit is for a 2003 and later model VHM Arms only. A pre-2003 VHM Arm is not equipped with a Swivel Cup that allows attachment of the Down Post. For pre-2003 VHM Arm applications, call GCX Customer Service at (800) 228-2555. Refer to the illustration on the right for identification of a pre-2003 VHM Arm.

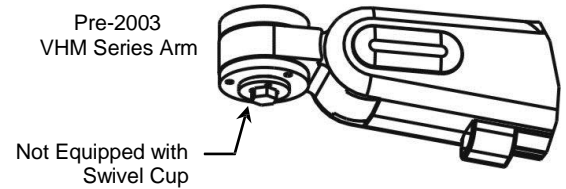

Attaching Down Post to VHM Arm (2003 and Later Models)

1. Remove plastic bolt cap from Swivel Cup (front end of the arm).
2. Using the 5/32" hex wrench provided, fasten Post to Swivel Cup with three (3) 10-32 x 3/8" SHCS as shown below

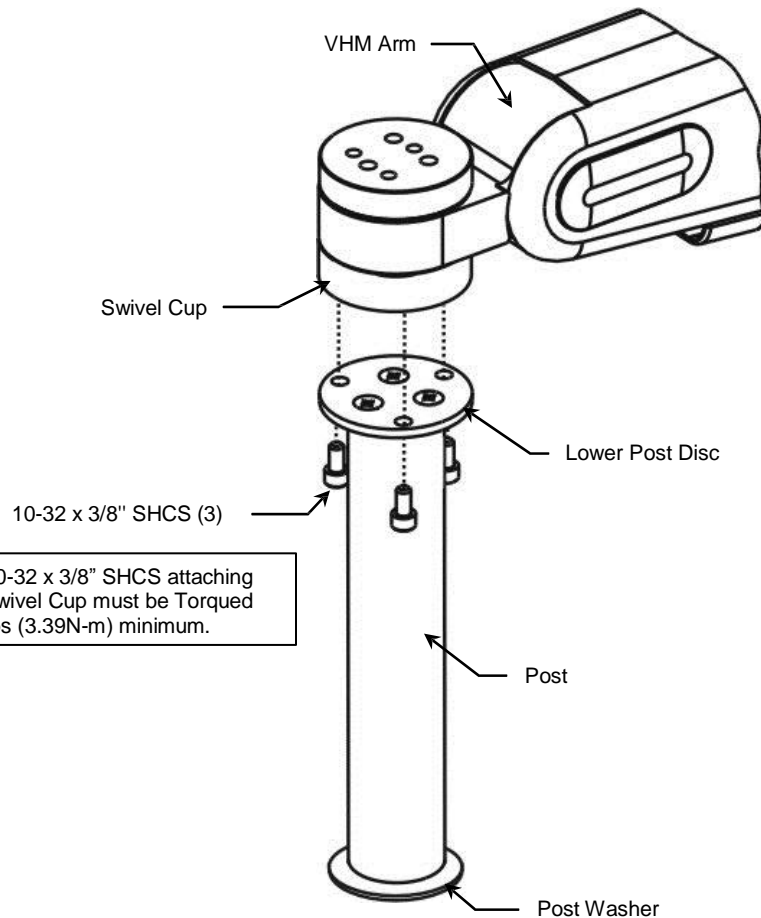
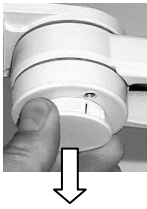

The (3) 10-32 x 3/8" SHCS attaching Post to Swivel Cup must be Torqued to 30 in/lbs (3.39N-m) minimum.

Routine Maintenance

Periodically inspect all fasteners associated with the mounting assembly. Tighten or Adjust as necessary for optimal operation and safety.

Cleaning the Mounting Assembly

1. The mounting assembly may be cleaned with most mild, non-abrasive solutions commonly used in the hospital environment (e.g. diluted bleach, ammonia, or alcohol solutions).
2. The surface finish will be permanently damaged by strong chemicals and solvents such as acetone or trichloroethylene.
3. Steel wool or other abrasive material should never be used.
4. Damaged caused by the use of unapproved substances or processes will not be warranted. We recommend testing of any cleaning solution on a small area of the mounting assembly that is not visible to verify compatibility.
5. Never submerge or allow liquids to enter the mounting assembly. Wipe any cleaning agents off the mounting assembly immediately using a water-dampened cloth. Dry the assembly thoroughly after cleaning.

CAUTION: GCX makes no claims regarding the efficacy of the listed chemicals or processes as a means for controlling infection. Consult your hospital's infection control officer or epidemiologist. To clean or sterilize mounted devices or accessory equipment, refer to the specific instructions delivered with those products.