

Installation Guide

Universal Thin Client Adapter Plate for 75/100mm VESA Mount

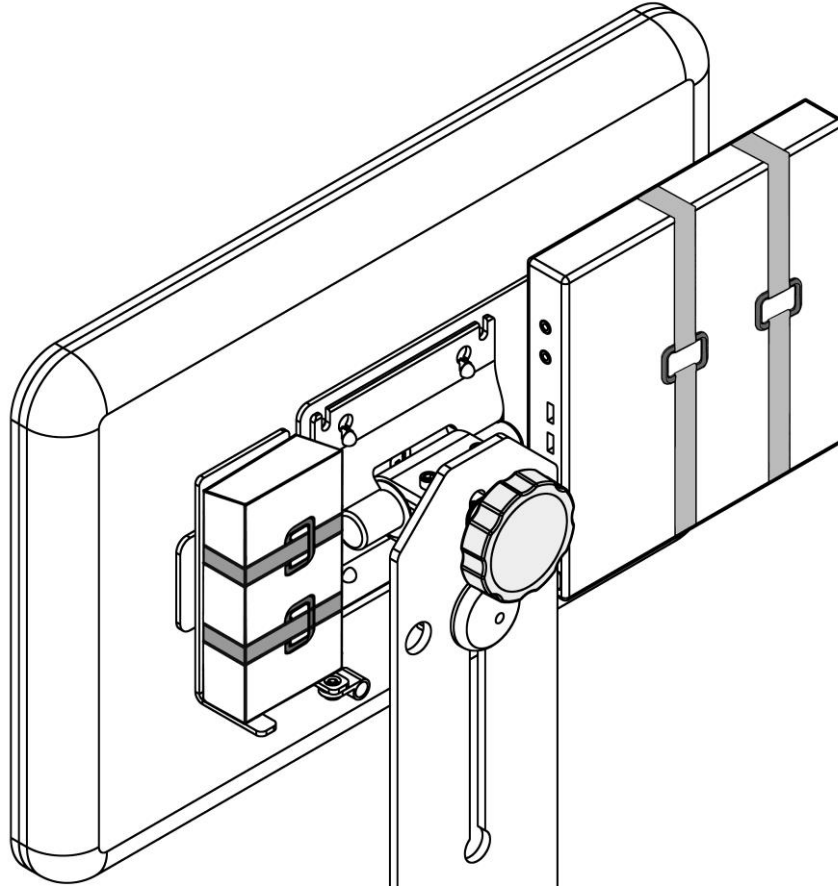

Parts Reference

The following parts and hardware are included in this installation kit:

Item #	Description	Qty.
1	Mounting Plate with Power Supply Bracket	1
2	Cap Nut	4
3	Lock Washer	4
4	Velcro Straps	2
5	M4 x 10 Flat Head Machine Screws (FHMS)	4
6	M4 x 12 Flat Head Machine Screws (FHMS)	4
7	FLP-0002-99 Hardware Kit (Not Shown)	1

Tools Required:

- 7mm Socket Wrench (Not provided)
- Phillips Screwdriver (Not provided)

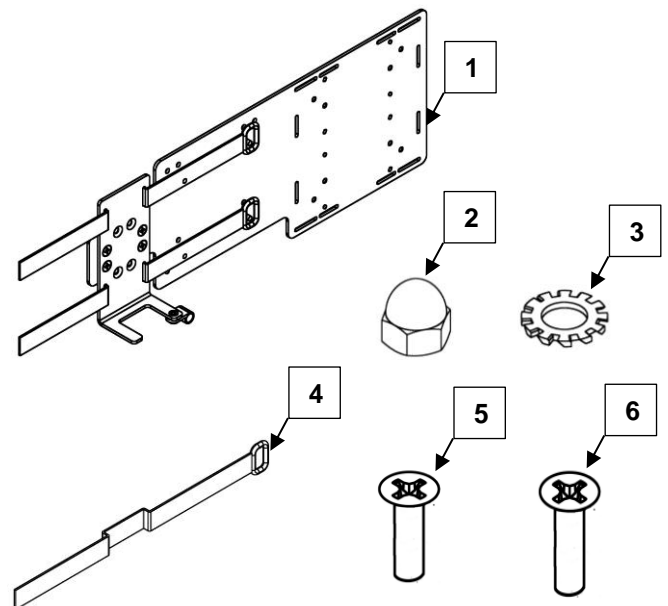

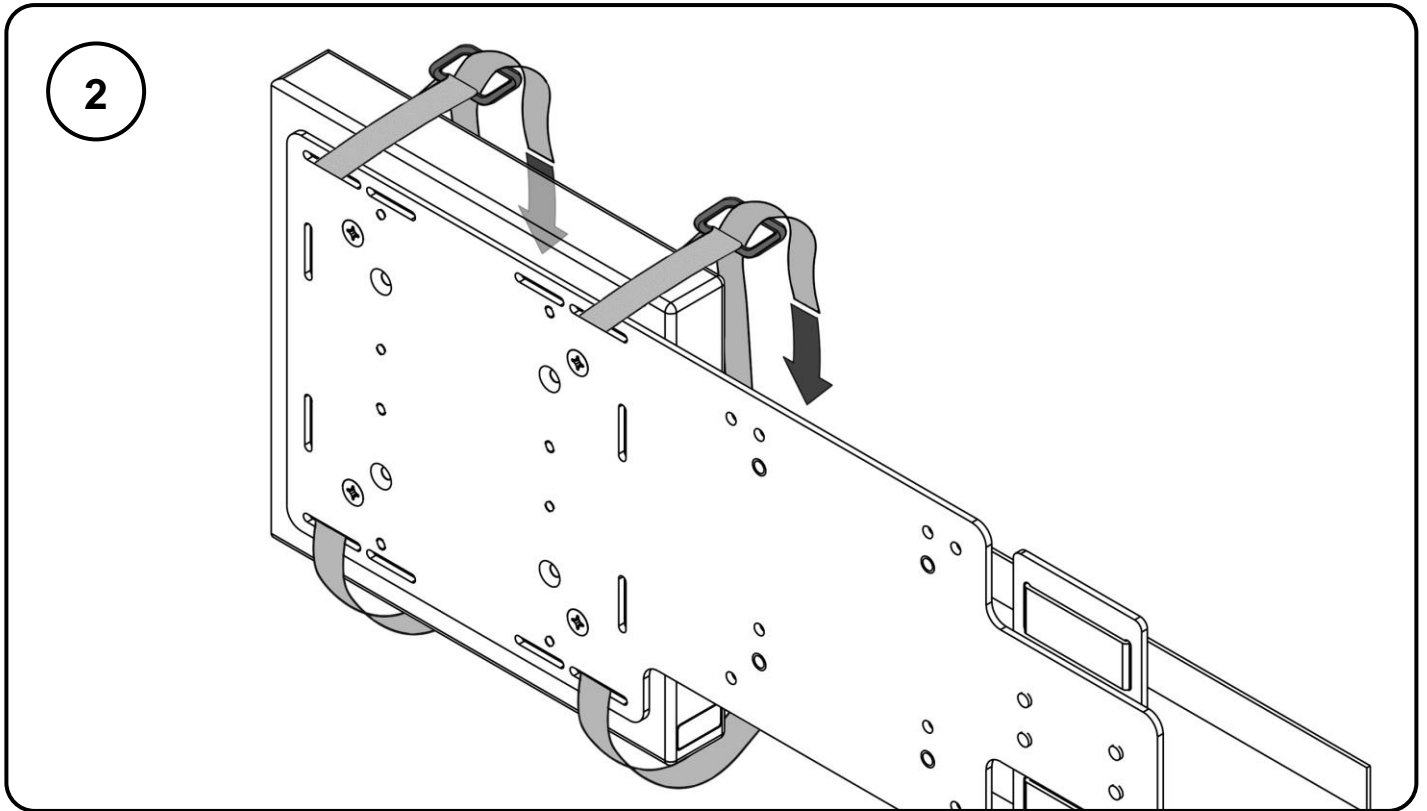
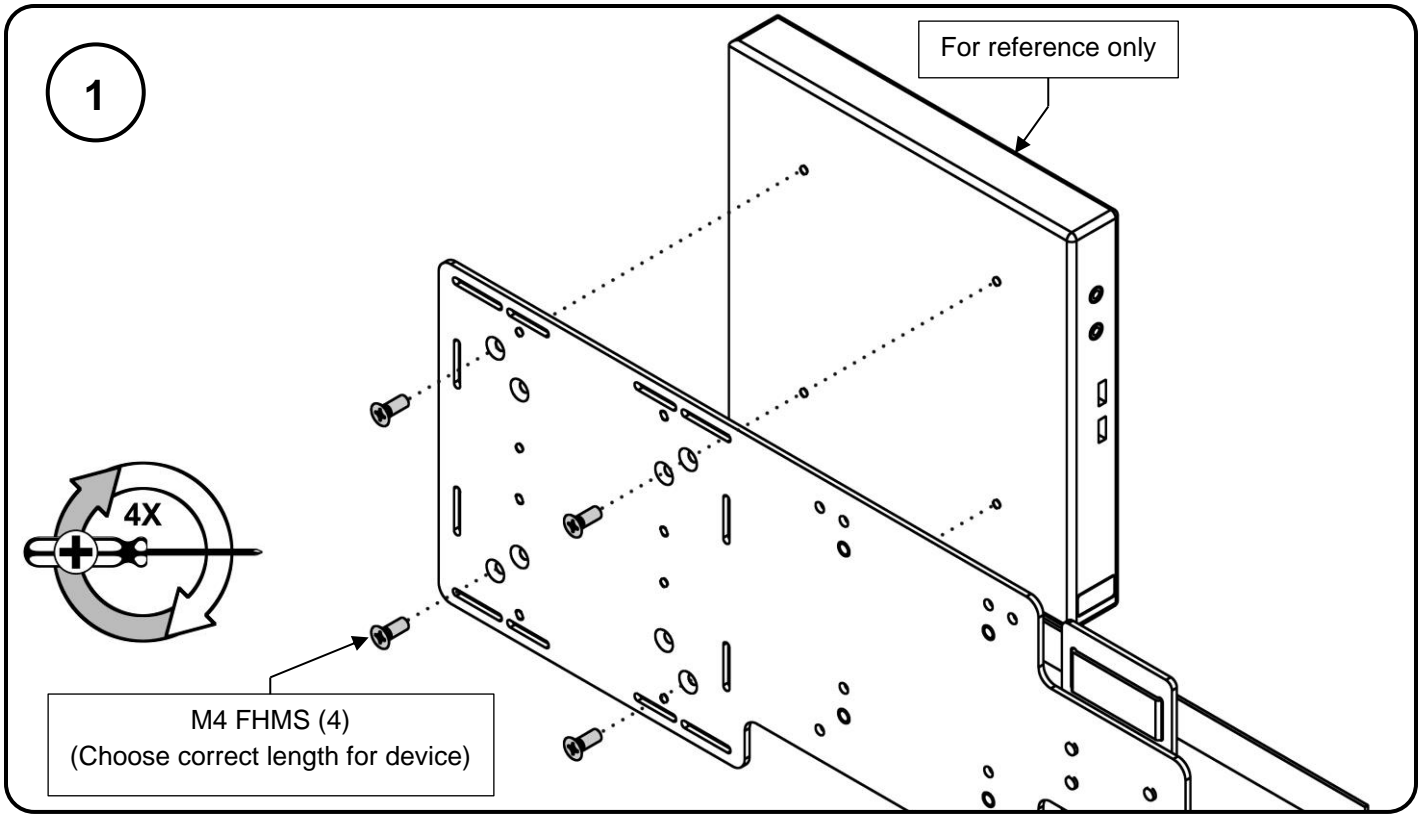

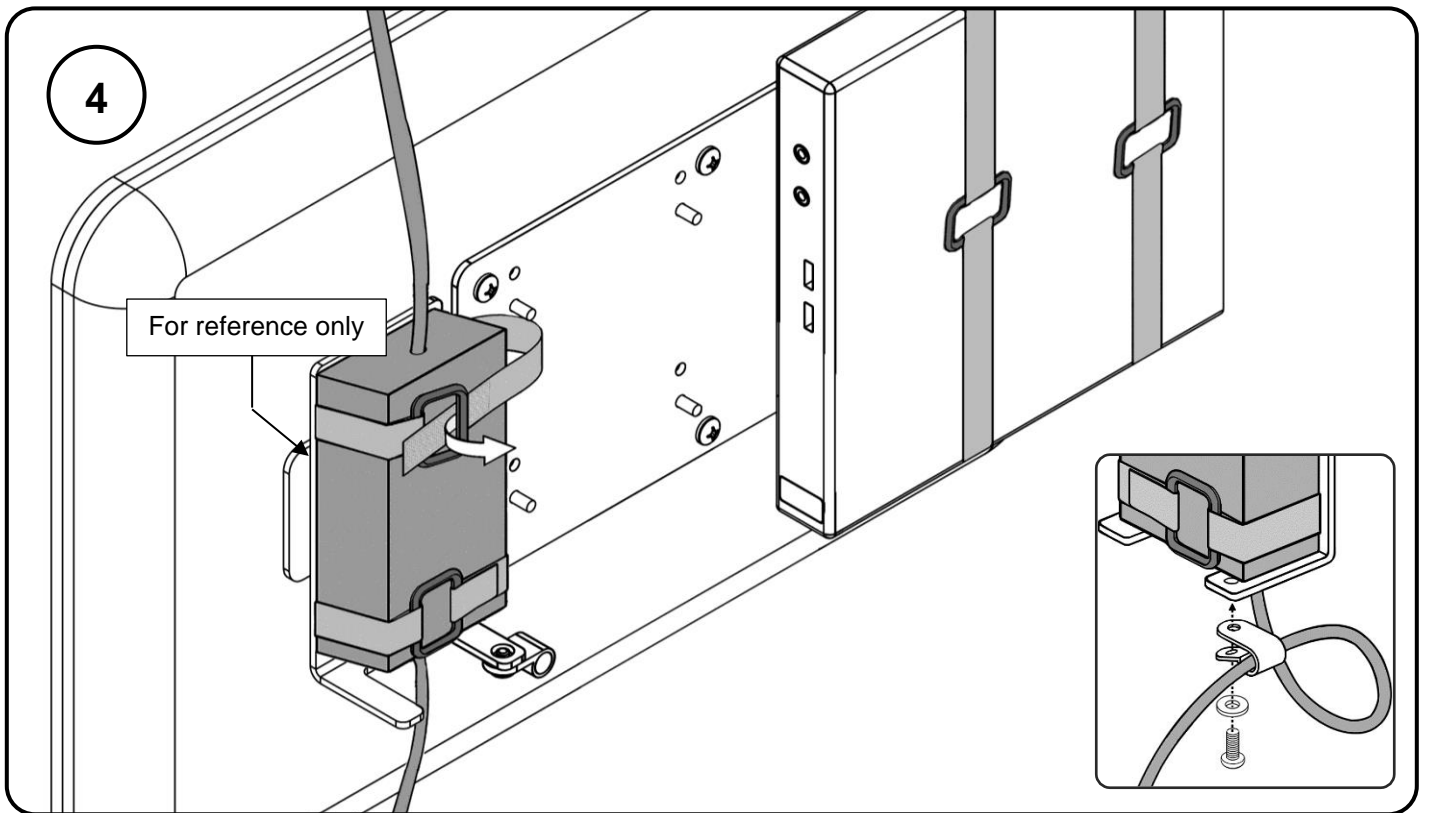
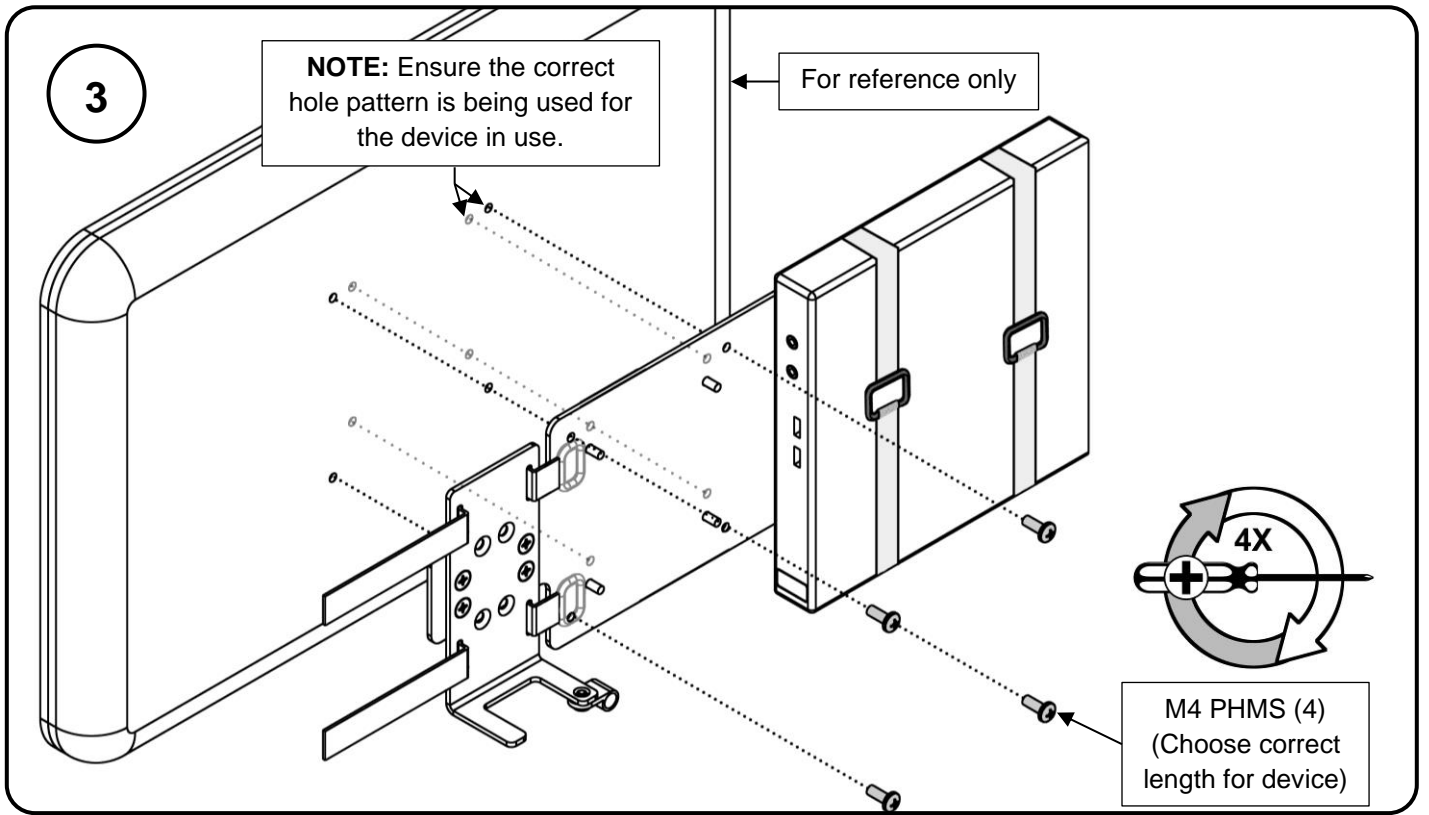

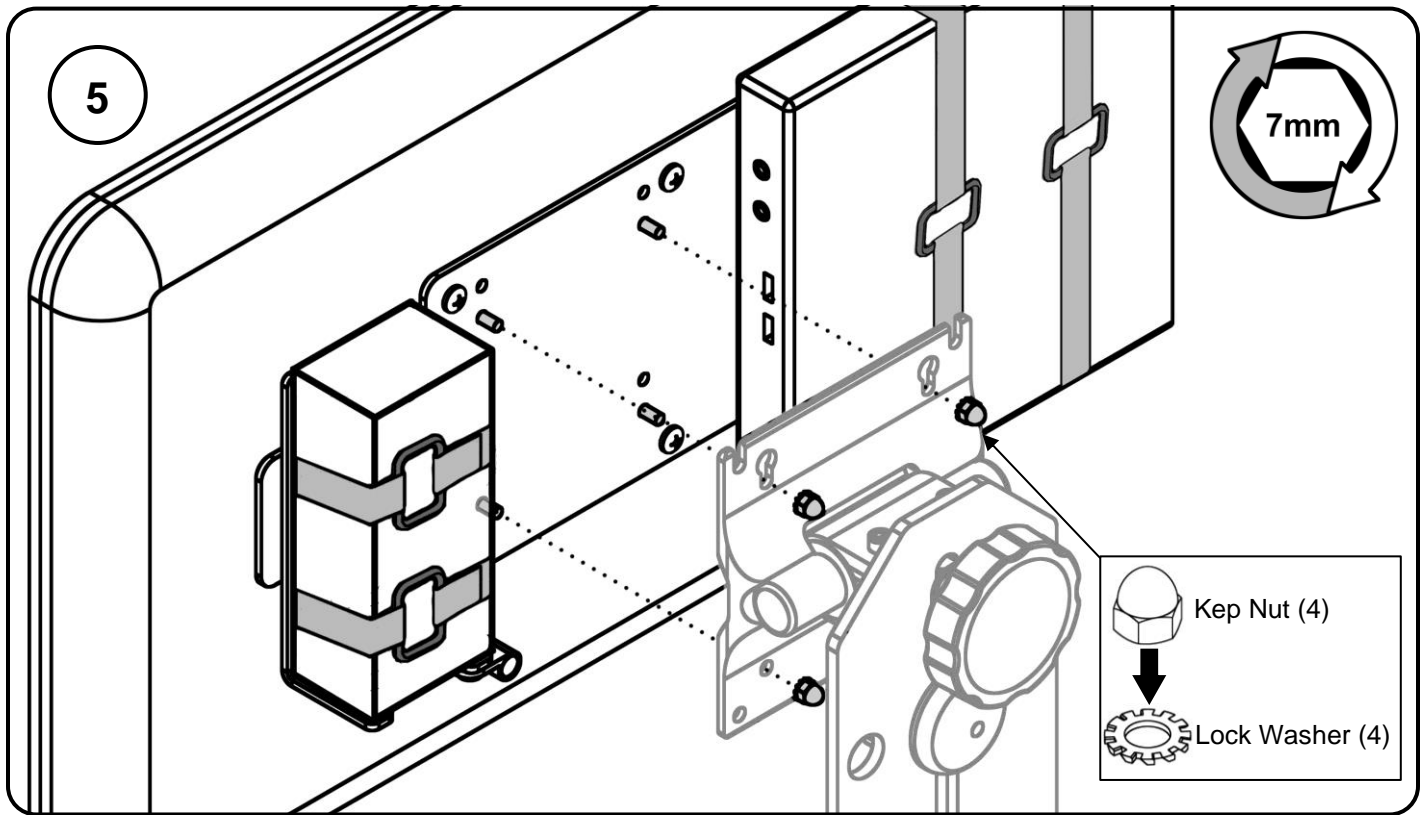

Routine Maintenance

Periodically inspect all fasteners associated with the mounting assembly. Tighten or adjust as necessary for optimal operation and safety.

Cleaning the Mounting Assembly

The mounting assembly may be cleaned with most mild, non-abrasive solutions commonly used in the hospital environment (e.g. diluted bleach, ammonia, or alcohol solutions).

The surface finish will be permanently damaged by strong chemicals and solvents such as acetone or trichloroethylene.

Steel wool or other abrasive material should never be used.

Damage caused by the use of unapproved substances or processes will not be warranted. We recommend testing of any cleaning solution on a small area of the mounting assembly that is not visible to verify compatibility.

Never submerge or allow liquids to enter the mounting assembly. Wipe any cleaning agents off the mounting assembly immediately using a water-dampened cloth. Dry the assembly thoroughly after cleaning.

⚠ CAUTION: GCX makes no claims regarding the efficacy of the listed chemicals or processes as a means for controlling infection. Consult your hospital's infection control officer or epidemiologist. To clean or sterilize mounted devices or accessory equipment, refer to the specific instructions delivered with those products.