

**Installation Guide**

**Power Strip Channel/Post Mount for Tripplite PS-415-HGULTRA**

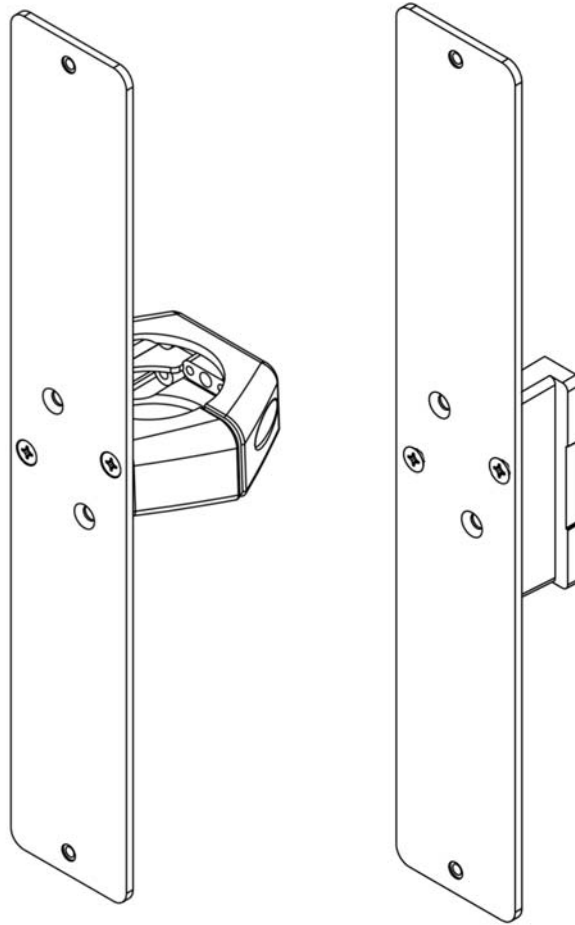

**Parts Reference**

The following parts and hardware are included in this installation kit:

| Item # | Description                                    | Qty. |
|--------|--|------|
| 1      | Power Strip Plate                              | 1    |
| 2      | Clamping Blocks                                | 1    |
| 3      | Molded Offset Slide                            | 1    |
| 4      | 10-32 X 5/16" Pan Head Machine Screws (PHMS)   | 2    |
| 5      | 10 X 5/8" Flat Head Sheet Metal Screws (FHSMS) | 2    |

**Tools Required:**

- 1/8 Hex Wrench (Provided)
- Philips Screwdriver (Not provided)

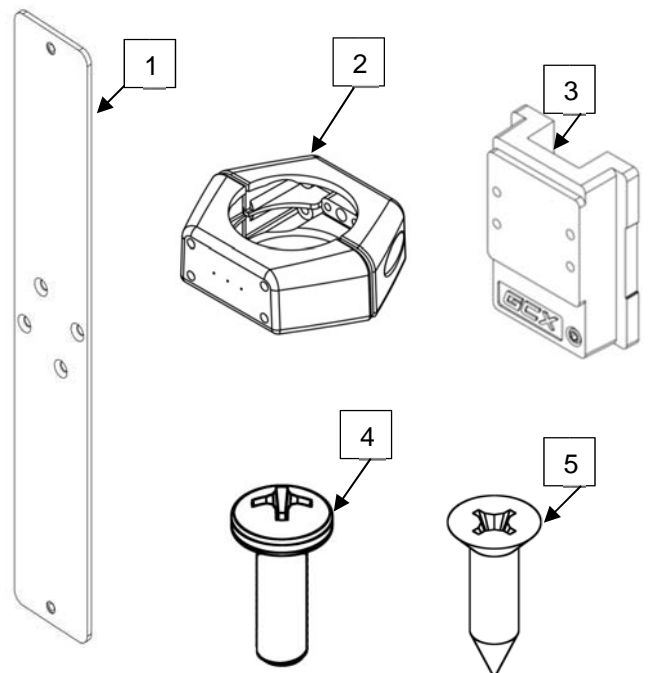

# Post Mount Installation

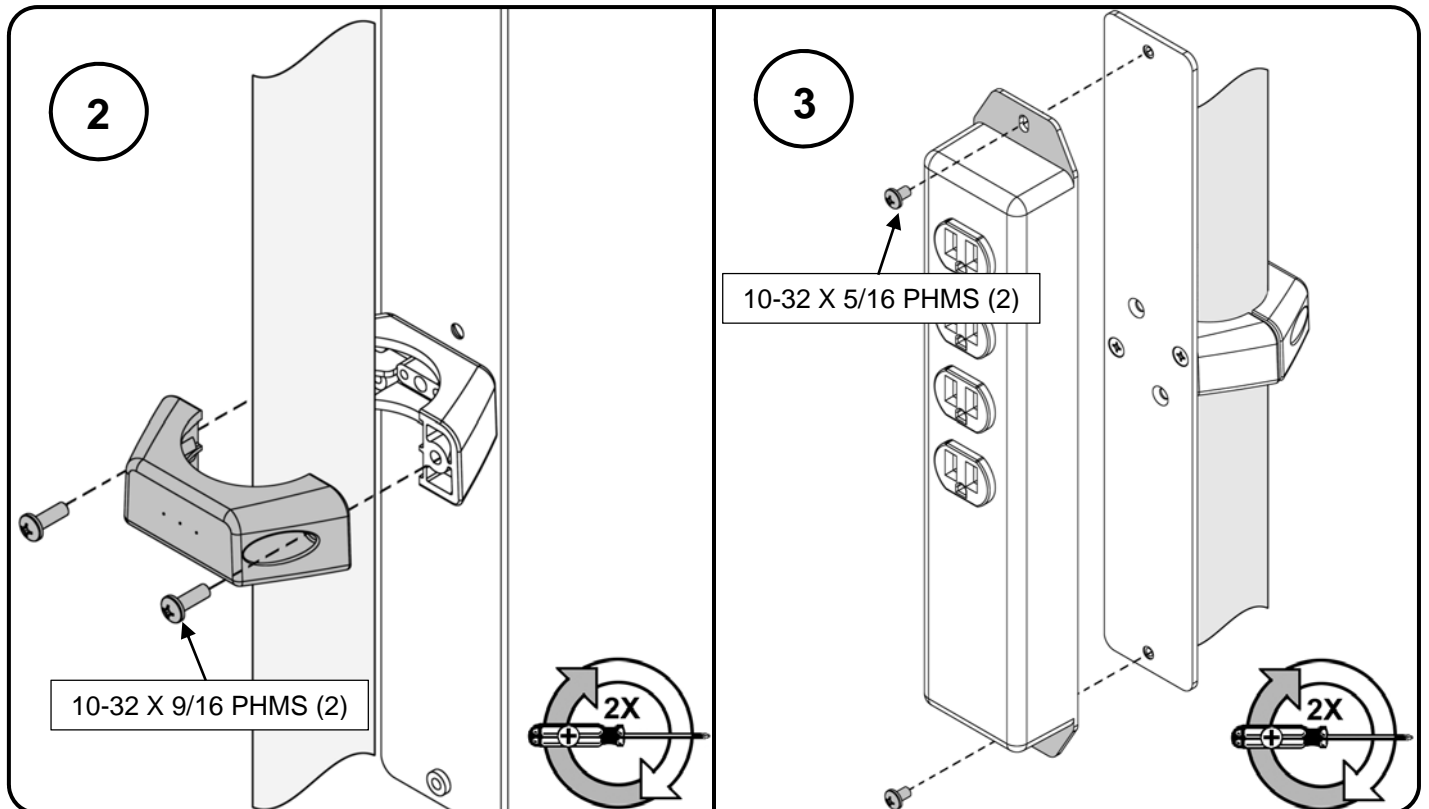
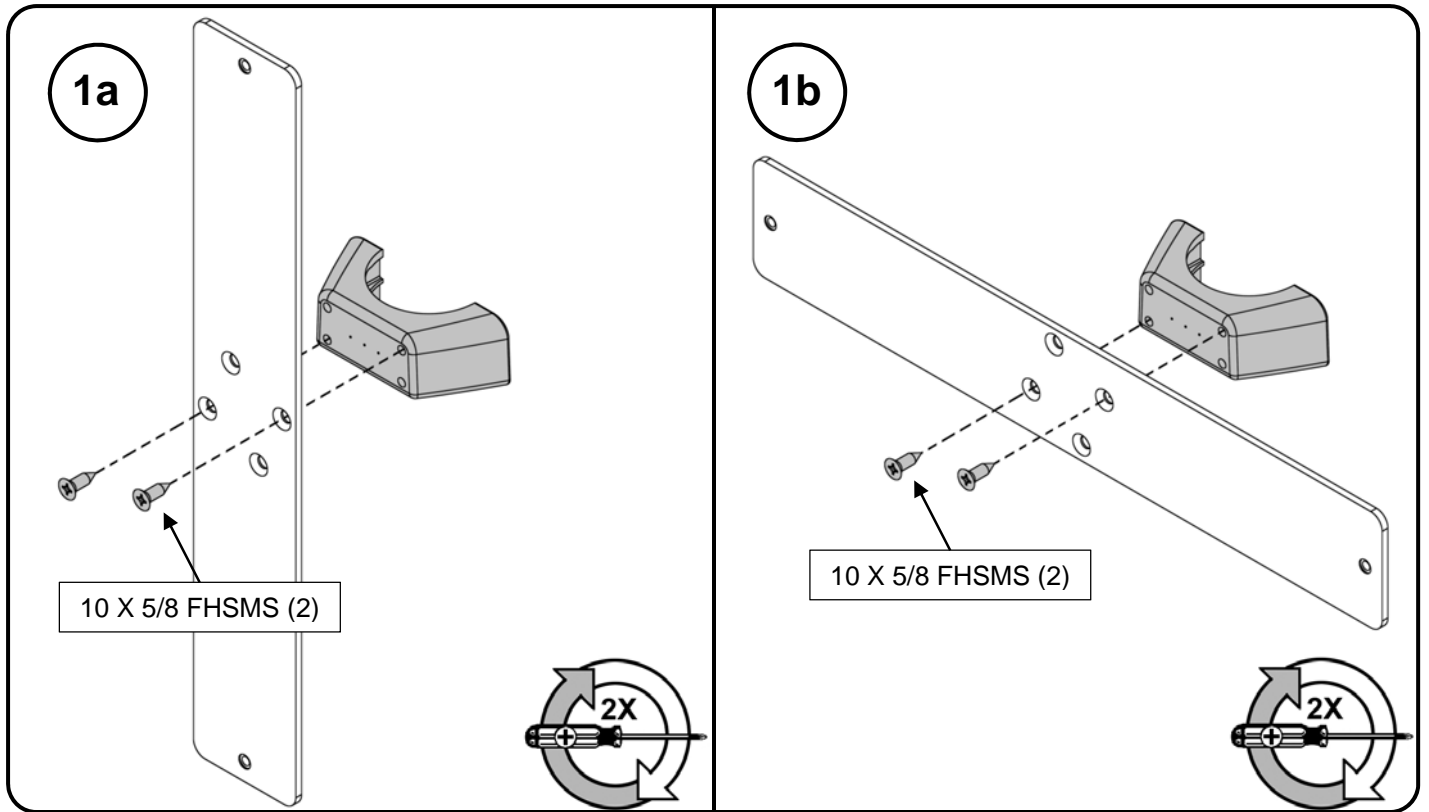

# Channel Mount Installation

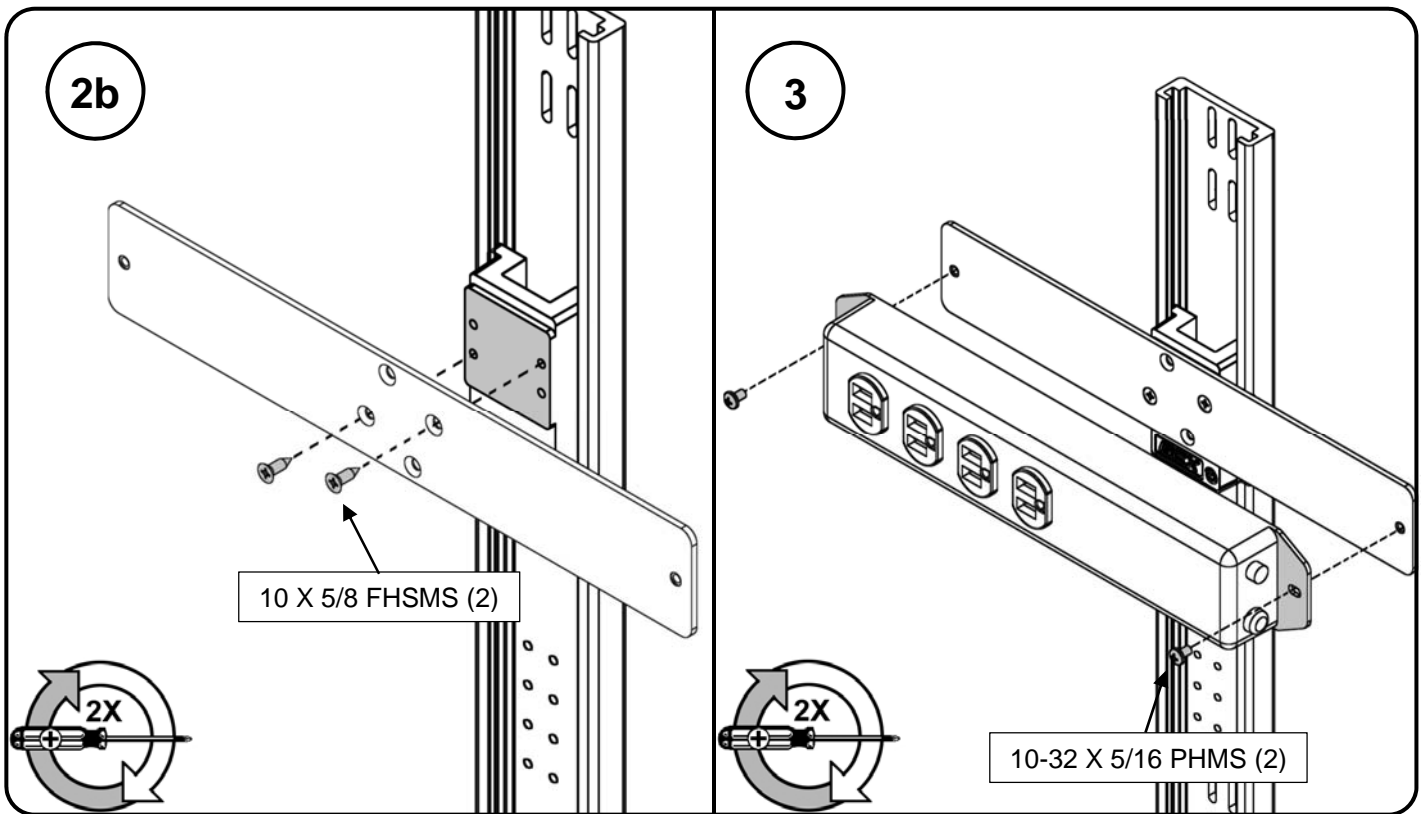
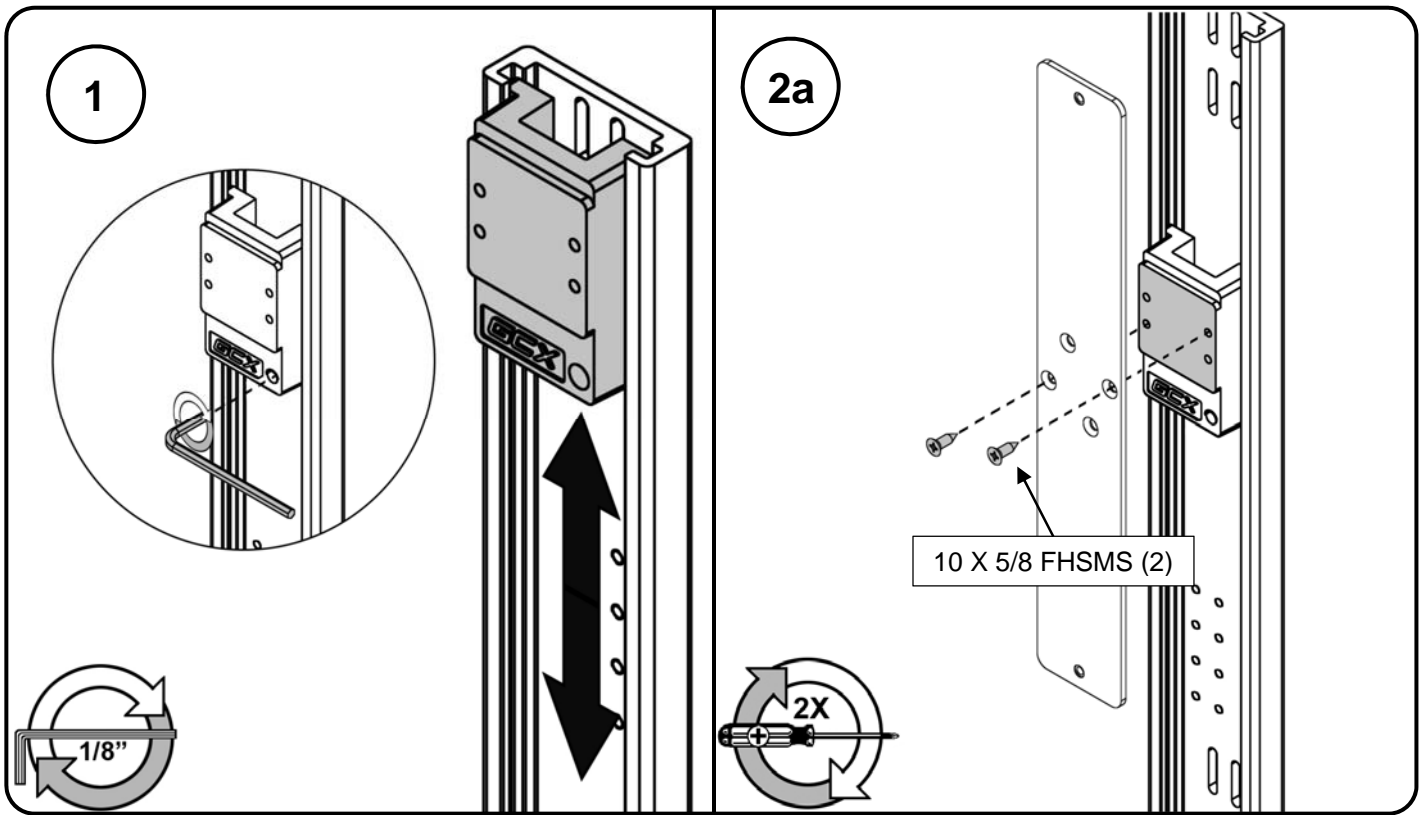

### **Routine Maintenance**

Periodically inspect all fasteners associated with the mounting assembly. Tighten or Adjust as necessary for optimal operation and safety.

### **Cleaning the Mounting Assembly**

The mounting assembly may be cleaned with most mild, non-abrasive solutions commonly used in the hospital environment (e.g. diluted bleach, ammonia, or alcohol solutions).

The surface finish will be permanently damaged by strong chemicals and solvents such as acetone or trichloroethylene.

Steel wool or other abrasive material should never be used.

Damage caused by the use of unapproved substances or processes will not be warranted. We recommend testing of any cleaning solution on a small area of the mounting assembly that is not visible to verify compatibility.

Never submerge or allow liquids to enter the mounting assembly. Wipe any cleaning agents off the mounting assembly immediately using a water-dampened cloth. Dry the assembly thoroughly after cleaning.



**CAUTION:** GCX makes no claims regarding the efficacy of the listed chemicals or processes as a means for controlling infection. Consult your hospital's infection control officer or epidemiologist. To clean or sterilize mounted devices or accessory equipment, refer to the specific instructions delivered with those products.