

**Installation Guide**

**VHM-P (Non-locking) Variable Height Arm with Fixed Front End  
For 94267/91393**

**Slide-Below-Arm Configuration**  
(Refer to Qualified Personnel)

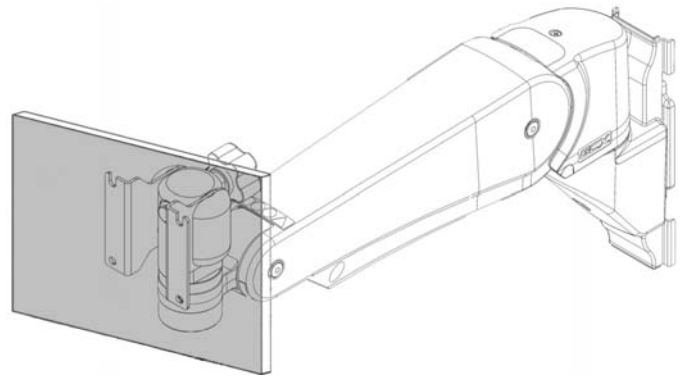
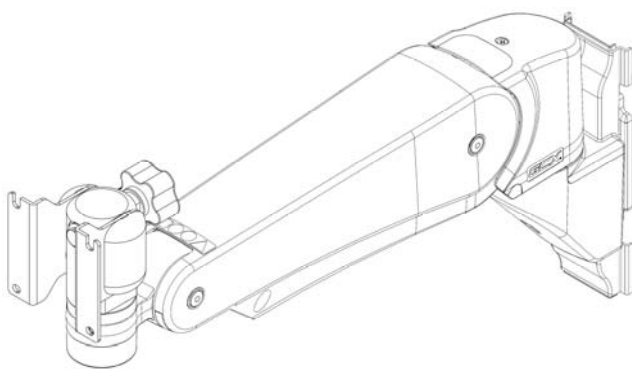

Ensure that the weight of the Device and mounting hardware (for example, L Bracket) does not exceed the load rating of the Arm. Check the bottom surface of the Arm for the "Load Range" label.

**Counter Balance Load Ranges:**

- 25 - 45 lbs / 11.3 - 20.4kg -- **Maximum Tilt Weight Limit: 30lbs / 13.6kg**
- Or
- 15 - 30 lbs / 6.8 - 13.6 kg

**Installation time**

Approximately 10-15 minutes

The Purpose of this manual is to describe general installation, operation, and adjustment procedures for the VHM-P Series Arm with Fixed Front End. This manual should be used in conjunction with any instrument- specific installation guides. Please read this manual and all instrument-specific material before installing or using this product.

**Table of Contents**

<b>1.0</b>	Parts Reference.....	2
<b>2.0</b>	Tools Required.....	3
<b>3.0</b>	Product Warning / Safety Labels.....	3
<b>4.0</b>	Installation, Operation, and Maintenance Warnings.....	3
<b>5.0</b>	Installing the Arm in Channel.....	5
<b>6.0</b>	Mounting the Device.....	6
<b>7.0</b>	Adjusting the Arm.....	7
<b>8.0</b>	Cable Management.....	8
<b>9.0</b>	Routine Maintenance.....	13
<b>10.0</b>	Cleaning the Arm.....	13
<b>11.0</b>	Troubleshooting the VHM-P Series Arm.....	14

## 1.0 Parts Reference

The following parts and hardware are included in this installation kit:

Item #	Description	Qty.
1	VHM-P Channel Mount Arm	1
2	Cable Cover	1
3	Pivot Cover (upper)	1
4	Pivot Cover (lower)	1
5	Cable Tie	7
6	16" (40.6 cm) Channel Cover	1
7	Adjustable Stop	1
8	30.5" (77.5 cm) Cable Sleeve	2
9	1/2" (13mm) x 3/4" (19mm) Wrench	1
10	1/8" Hex Wrench ( <i>not shown</i> )	1
11	5/32" Hex Wrench ( <i>not shown</i> )	1
12	Pivot Cover Cap	1
13	Slide to Channel Transition Cover	1

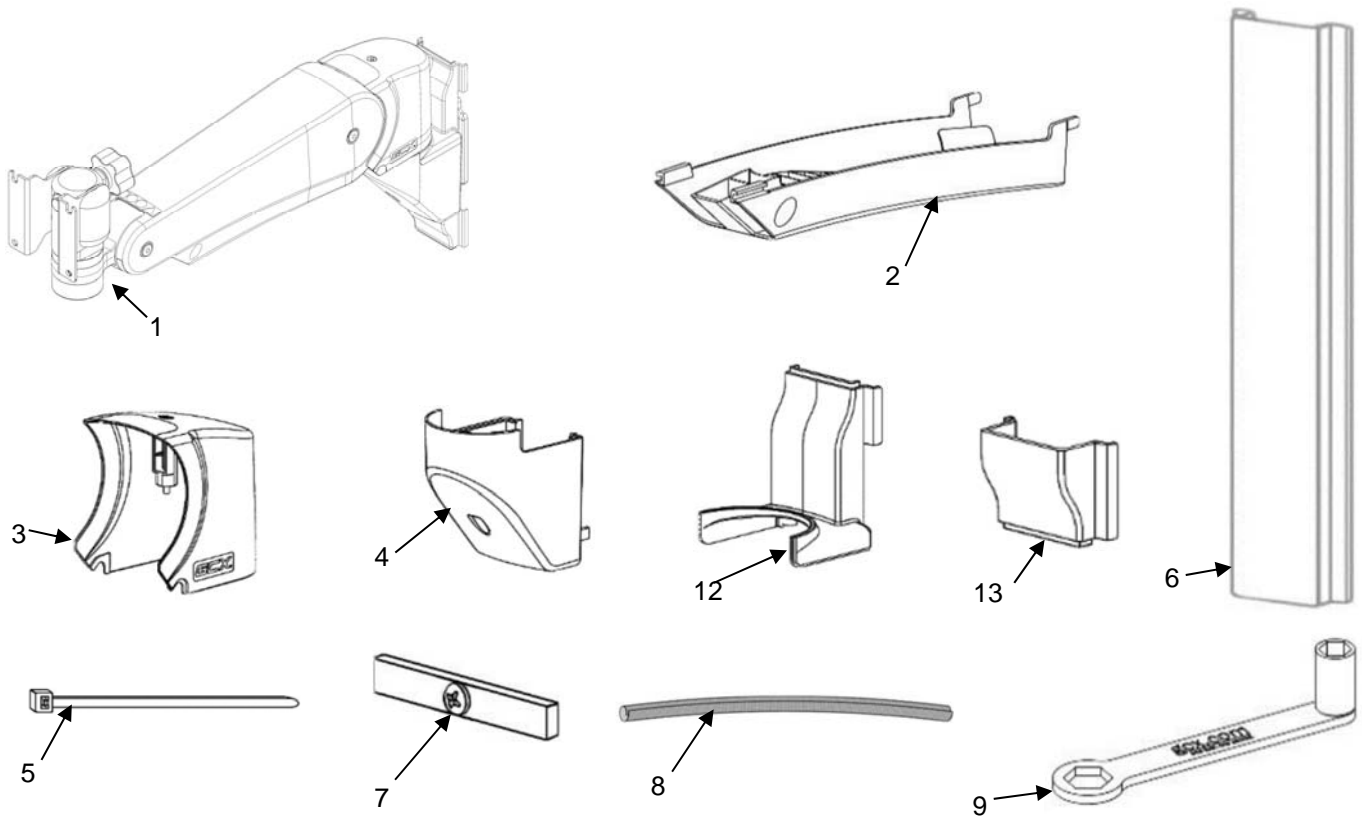

## 2.0 Tools Required

The tools listed below are required to install and adjust the Arm.

### Provided

1. 1/8" Hex Wrench
2. 5/32" Hex Wrench
3. 1/2" (13 mm) / 3/4" (19 mm) Combination Wrench

### Not Provided

4. #2 Philips Screwdriver
5. Scissors, utility knife or similar cutting tool
6. Wire Cutters (for cable ties)
7. 3/4" (19mm) Socket Wrench (for front end pivot tension)

## 3.0 Product Warning / Safety Labels

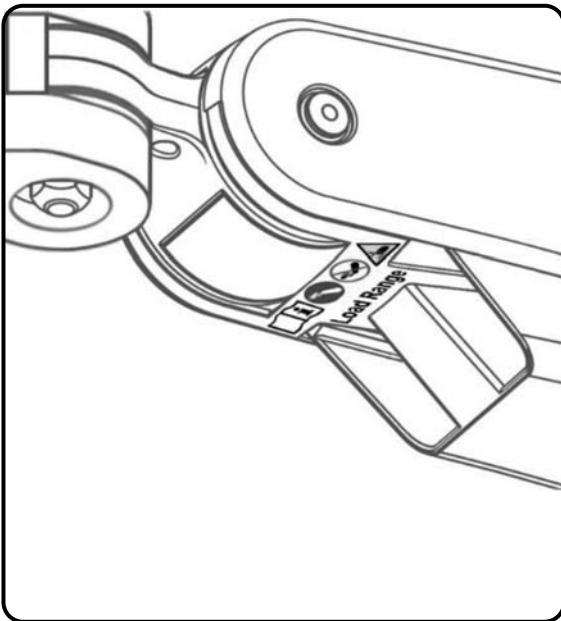
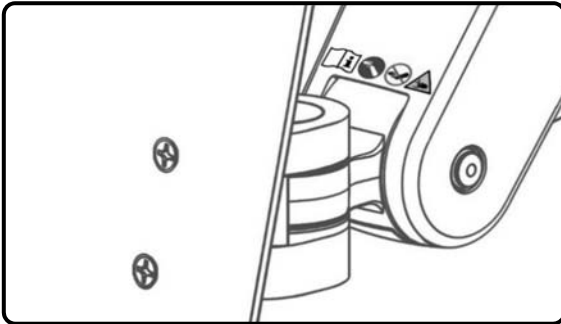

Refer to Installation Guide for additional information.



Remove the Device only when the Arm is at the highest position.



Do not remove device when arm is in a lowered position.



Potential pinch points that may cause personal injury

**Counter Balance Load Range:**  
**25 – 45 lbs / 11.3 – 20.4 kg**  
**or**  
**15 -30 lbs / 6.8 – 13.6 kg**

## 4.0 Installation, Operation, and Maintenance Warnings

This section contains warnings regarding the installation, operation, and maintenance of the Arm. This section must be read in its entirety before installing, operating, and maintaining the Arm. Failure to follow these warnings may result in damage to equipment or injury to personnel.



## Warnings

- Do not position the Arm or mounted Device above a patient. Note that the Arm has a wide range of motion both up/down and side to side. Please consider carefully the Device being mounted and the proximity of the mounting assembly to other equipment, hospital personnel, and the patient. GCX recommends that the hospital's risk management personnel verify that the application is appropriate prior to installation and use of the Arm.
- Before the Arm is Channel mounted, verify that the channel has been installed and approved in accordance with the channel installation guide. Documents are available on our website: [www.gcx.com/support](http://www.gcx.com/support).
- Ensure that the weight of the Device and Flat Panel being mounted does not exceed the load rating of the Arm. Check the bottom surface of the Arm for the "Load Range" label. Refer to Section 3.0.
- Do not use power tools to make any adjustments on Arm.
- The mounted device or arm may move suddenly due to normal wear or improper adjustment of the, swivel, and pivot functions (see sections 7.2 and 7.3), improper counterbalance (Section 7.1) or ultimately, gas spring end of life. The gas spring has a limited life span and will lose some strength over a long period of time. **The Arm must be inspected and maintained at least once a year.** This inspection must include the steps outlined in Section 9.0.
- Failure to periodically inspect and adjust the Arm as instructed may result in damage to equipment or injury. If you are unable to adjust the arm or require service, contact GCX at technical support at 800.228.2555 or + 1 707.773.1100.
- Note that the VHM-P Arm has a wide range of motion both up/down and side to side. Please consider potential pinch points that may cause personal injury.

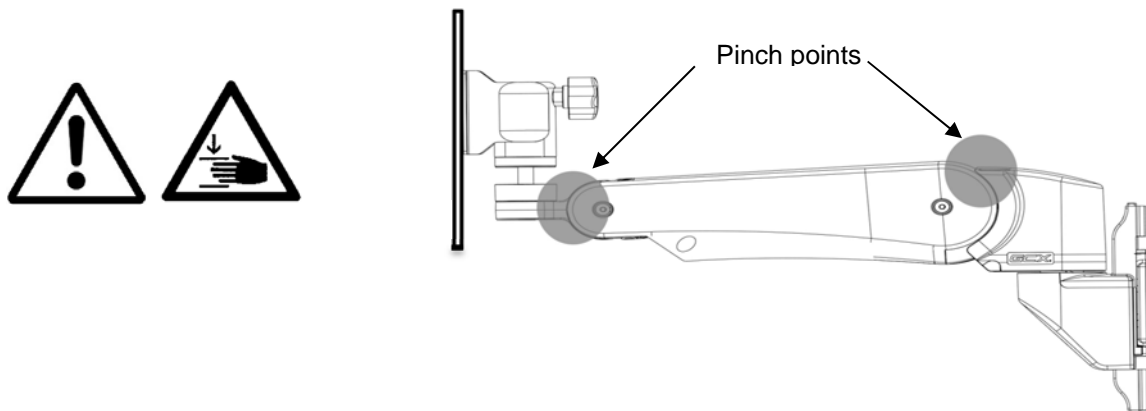

- Remove the Device only when the Arm is at the highest position. Due to the counter balance function, the Arm will naturally rise to the highest position when weight is removed. This can happen suddenly if the weight is removed at any height other than the highest point.

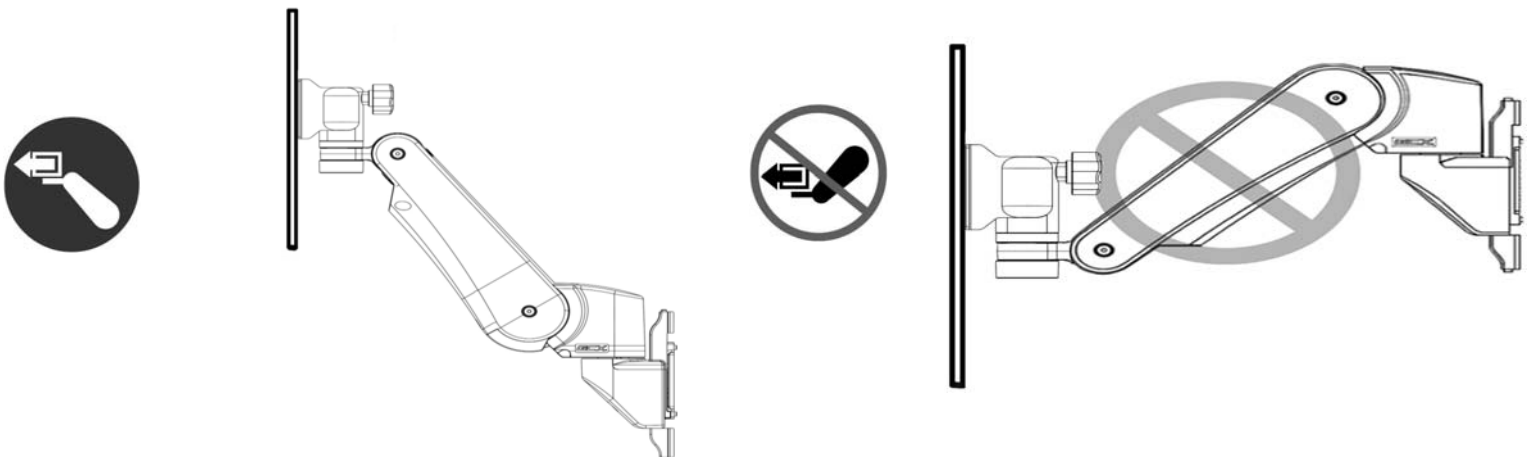

- Due to risk of personal injury or damage to the Arm, the Arm housing must never be disassembled by non-GCX personnel. Failure to comply will void the warranty.

## 5.0 Installing the Arm in Channel



Before mounting the Arm, verify that the Channel has been installed and approved in accordance with the channel installation guide included with the channel.

5.1. Insert Adjustable Stop into top of channel and slide to desired mounting position.

5.2. Using a #2 Philips screwdriver, tighten the center screw to the secure position.

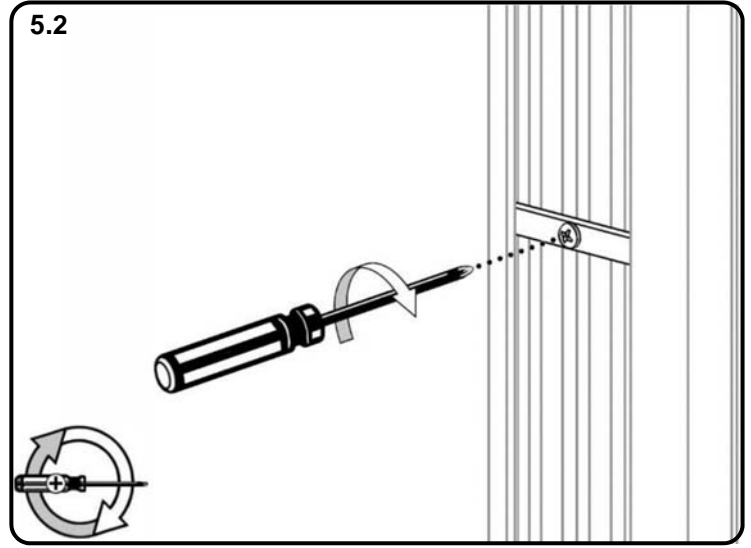
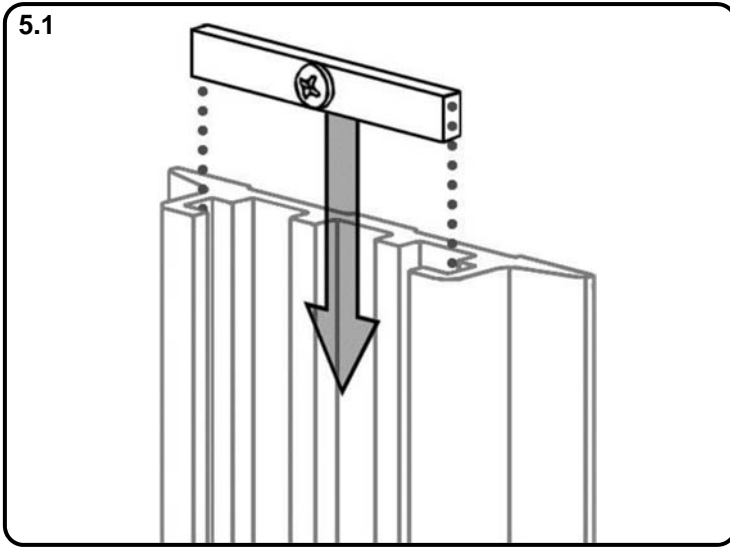

5.3. While supporting the Arm, guide the Slide into the top of the channel and position the Arm onto the Adjustable Stop.

5.4. Using the 1/8" hex wrench provided, tighten the (2) upper and the (2) lower set screws in Slide to secure position of Arm.

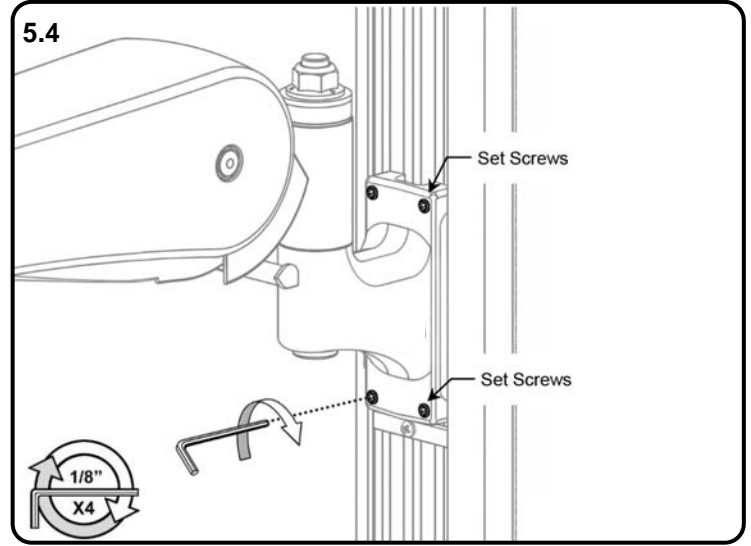
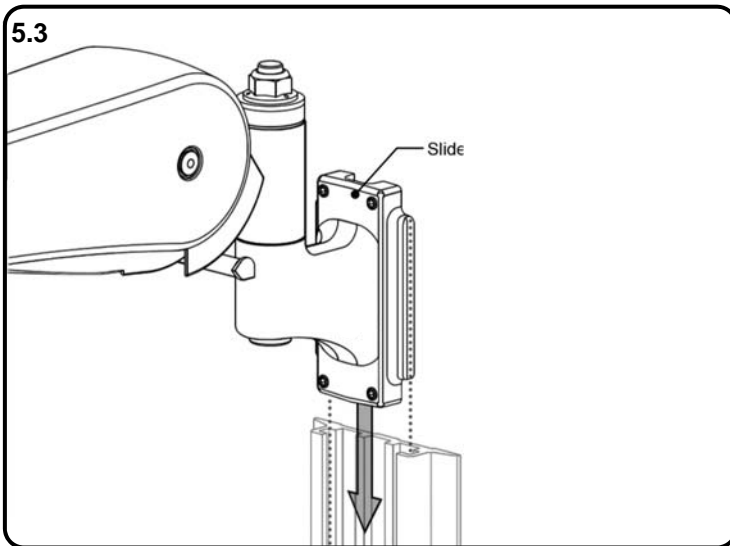

## 6.0 Mounting the Device (94267 and 91393)

**Installation Note:** M6 Mounting Screws supplied by Spacelabs.

1. Thread (2) screws into the (2) upper threaded mounting holes on the Monitor/Display Mount leaving 1/2 of the thread exposed. Slide Monitor/Display Mount down onto Wall Mount Arm as shown (below left).
2. Thread (2) screws into the lower mounting holes as shown (below right). Using a Philips screwdriver, tighten all screws.



### Tilt Adjustment and Swivel Tension

**Tilt Adjustment** is achieved by tightening or loosening the Adjustment Knob on the back of the Tilt Swivel Assembly (below left).

**Swivel tension** can be adjusted by tightening or loosening the locknut on the bottom of the Tilt Swivel Assembly with a 1/2" wrench (below right).

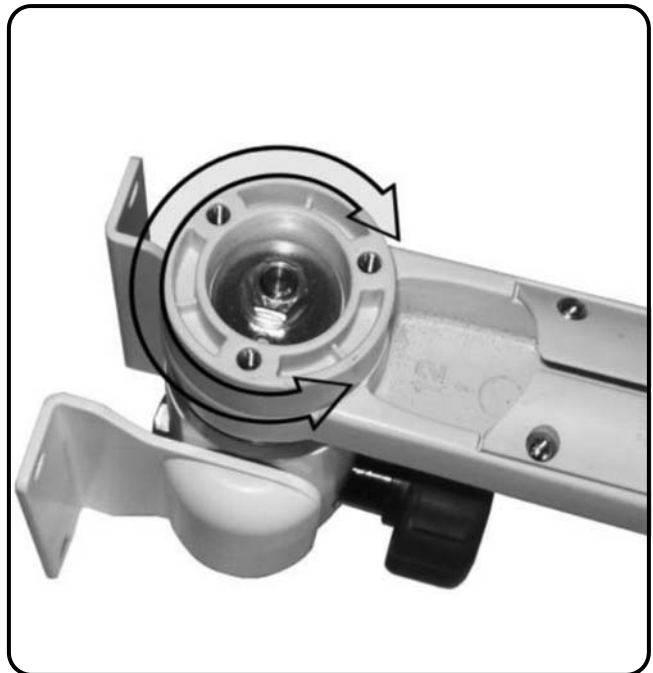
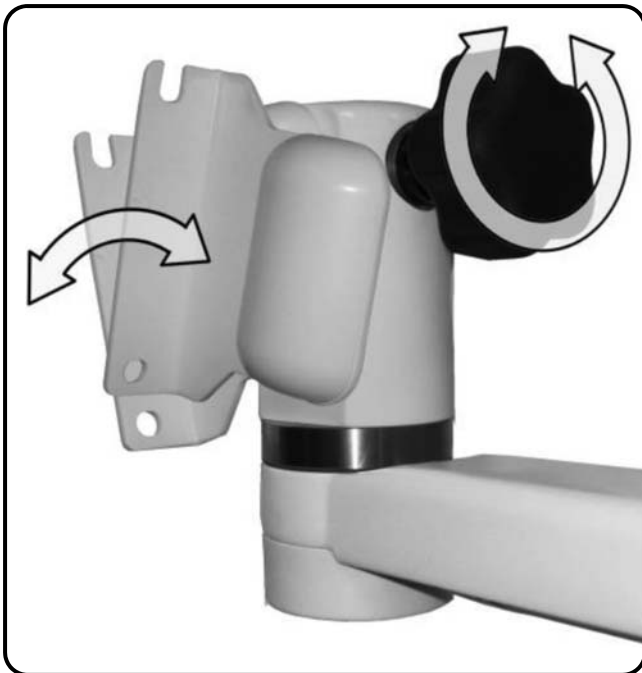

## 7.0 Adjusting the Arm

**Installation note:** Adjustments are factory pre-set. However, adjustments to counterbalance, swivel tension, and pivot tensions may all be required to achieve optimal arm performance. Detailed instructions for making follow in the section below. When properly adjusted the mounted device will move easily throughout the arms full range of motion. Refer to the Routine Maintenance Check List in Section 9 for a quick guide to these functional checks.



**Caution:** the counterbalance procedure is performed with the device(s) and accessories installed on the Arm. When unlocking the arm to perform the counterbalance procedure, use caution as it may be necessary to support the weight of the arm/mounted device(s). This process may require an additional person. Use caution while performing this procedure.

### 7.1 adjusting Counterbalance

**Counterbalance Adjustment-** The Counterbalance Adjustment Screw is located under the Arm in front of the rear pivot assembly. Grasp the mounted device and move the Arm to a level horizontal position. Using a 5/32" hex wrench, tighten (+) or loosen (-) the counterbalance Adjustment Screw. Counterbalance is correctly adjusted When the mounted device can be moved up or down with Minimal force and does not rise or fall after releasing the Arm.

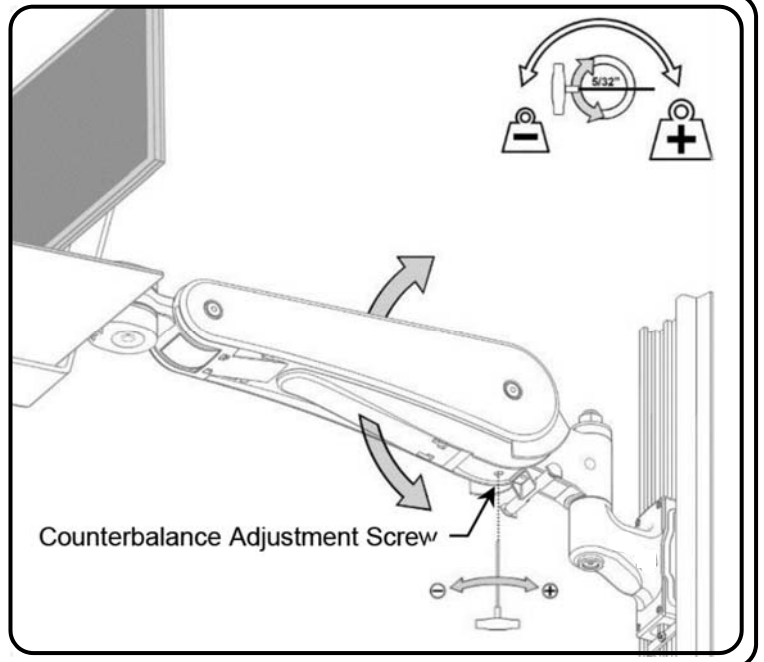

### 7.2 Swivel tension Adjustment

To adjust the tension at the front end:

- 1) Tighten (+) or loosen (-) the Swivel Tension Nut with a 3/4" (19 mm) socket wrench until desired tension is achieved. Total adjustment is approximately 1/4 to 1/2 turn

**Caution:** Do not remove the Swivel Tension Nut.

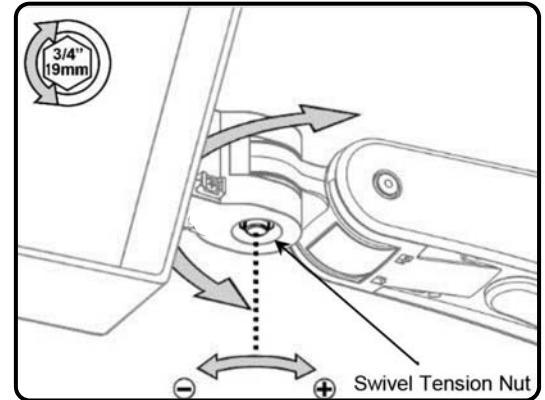

### 7.3 Pivot Tension Adjustment

To Adjust the pivot tension (rear pivot point closest to channel):

- 1) Tighten (+) or loosen (-) the Swivel Tension Nut with a 3/4" (19 mm) socket wrench until desired tension is achieved.

**Caution:** Do not remove the Pivot Tension Nut.

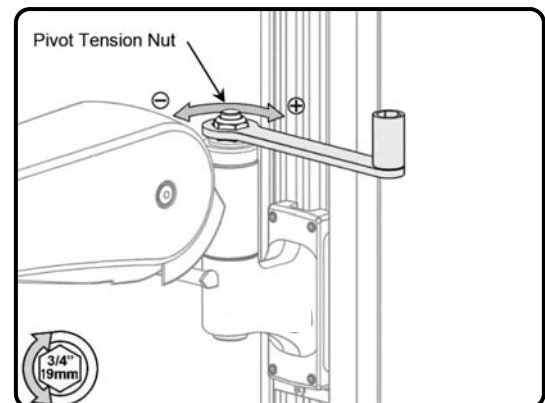

## 8.0 Cable Management

### Cable Management Overview

**Attention:** Follow these cable routing instructions to ensure unrestricted arm range of motion and to avoid possible damage to cables or the mounted device.

In section 8.1 cable service loops (black slack) are established to prevent restricting range of motion when the arm or mounted device is repositioned. Cables are anchored at the front and rear of the arm to preserve the necessary service loops. Cable sleeves are provided to assist in determining the correct service loops and to help protect and organize the cables.

In sections 8.2-8.16 cables are routed from the rear of the arm into the channel and protected by plastic covers.

### 8.1 Preparing Service Loop

**Maintain a 29-1/2" (75 cm) service loop** between anchor points and the anchor cables (and sleeves) at the rear of the arm using cable ties. Secure only one cable bundle, each a maximum 1/2" (1.3 cm) wide, per anchor. Cable anchors further from the channel should be used prior to the anchors closer to the channel.

**Using the provided cable sleeves is recommended but optional.**

Insert cables into sleeves as shown below.

Use a minimum 1/4 circle overlap to avoid unraveling during use.

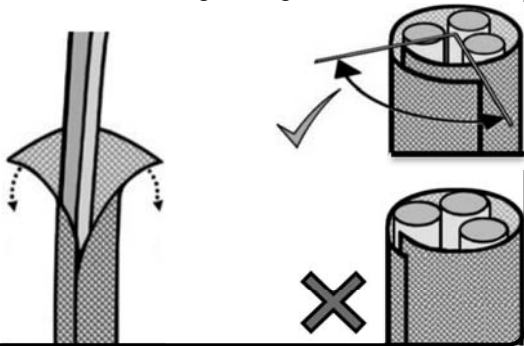

**Position cable tie heads flush against the arm while Tightening.**

The provided cable ties have a release tab at the head. Pliers may be used to help pull ties taut to secure cable bundles.

Clip excess length of cable ties as flush as possible to avoid creation of a sharp edge.

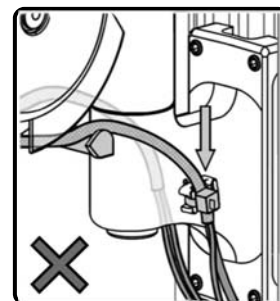
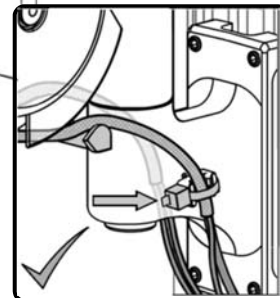
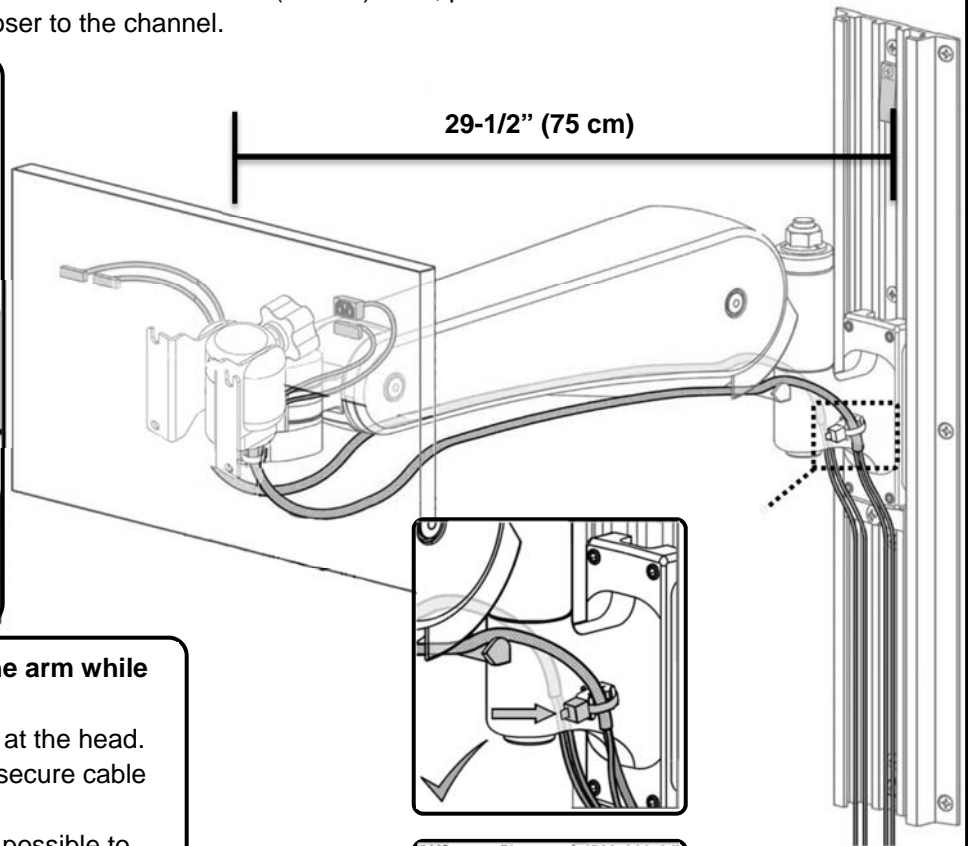
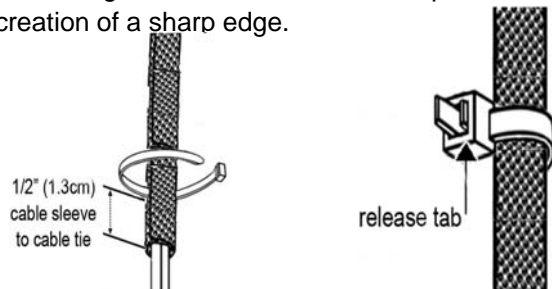



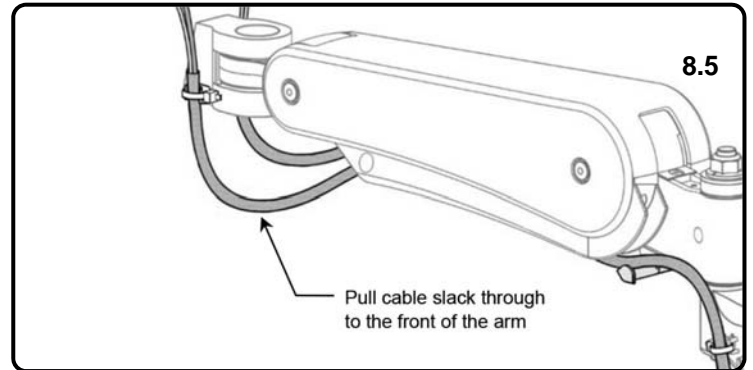
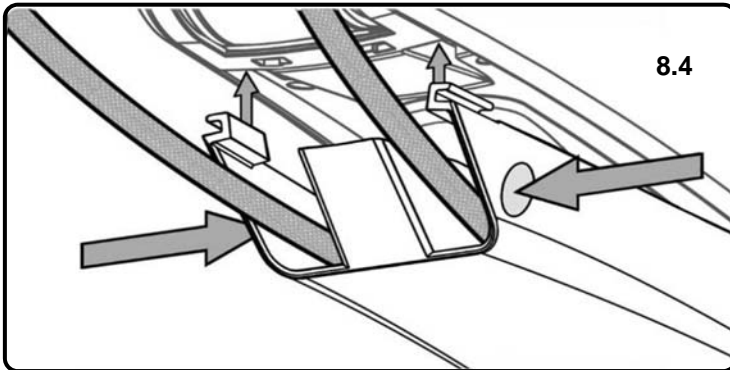
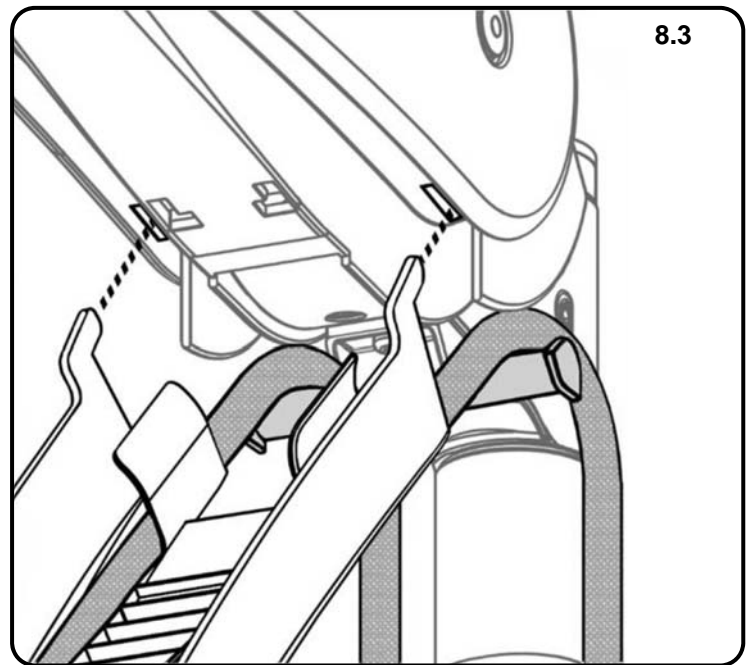
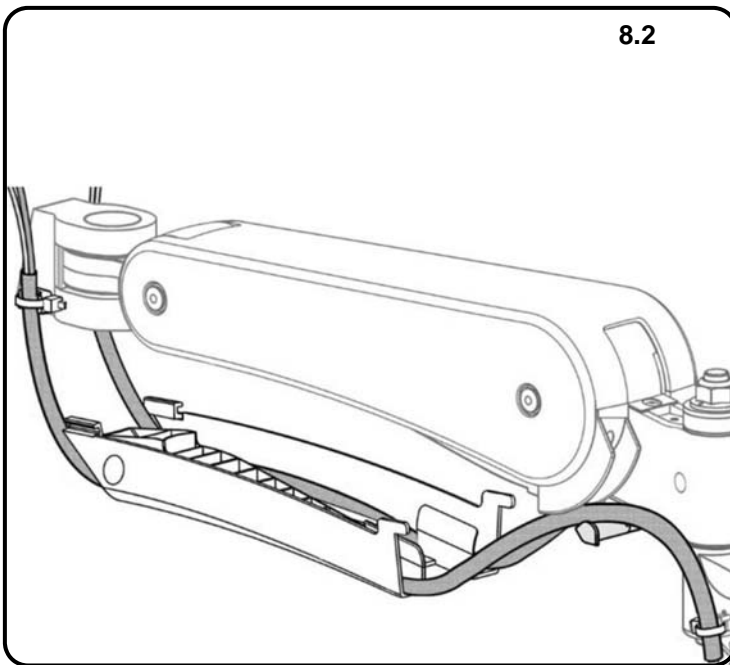

## 8.6 Routing Cables Upward into the Channel

**8.6.1** If all cables will route downward into the channel Below the arm then simply let them hang from the rear Cable anchors and proceed to the next section.

### 8.6.2 For cables routing upwards into the channel above the arm

**8.6.2.1** First wrap each cable bundle from the downward-going side, underneath the slide, and then back upward along the opposite (upward-going) side.

**8.6.2.2** On the upward-going side, secure the bundle in the unused cable anchor closest to the channel.

**Attention:** If both cable anchors on the upward-going side are being used then it is not recommended to route cables upward on that side. Attempting to do so may prevent the slide covers from proper fit and function.

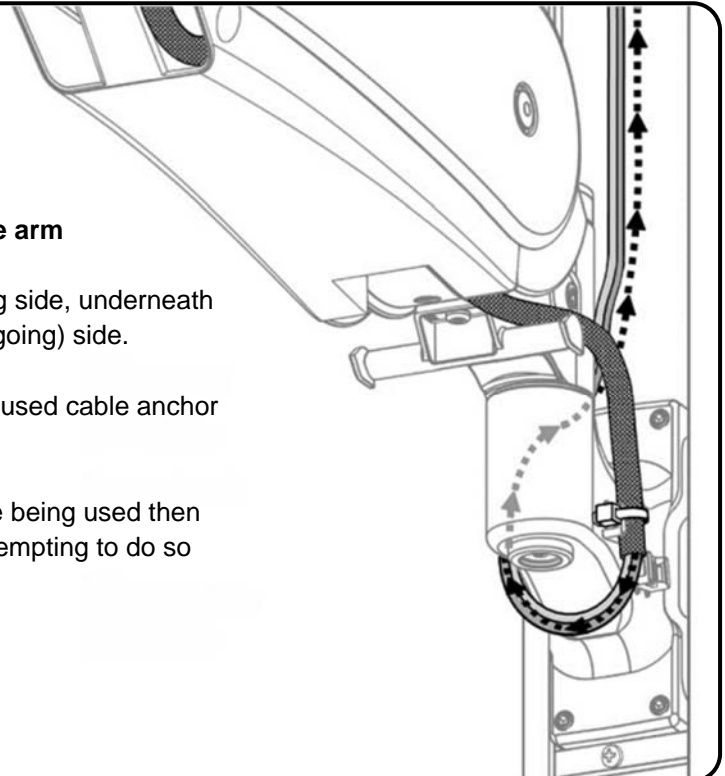

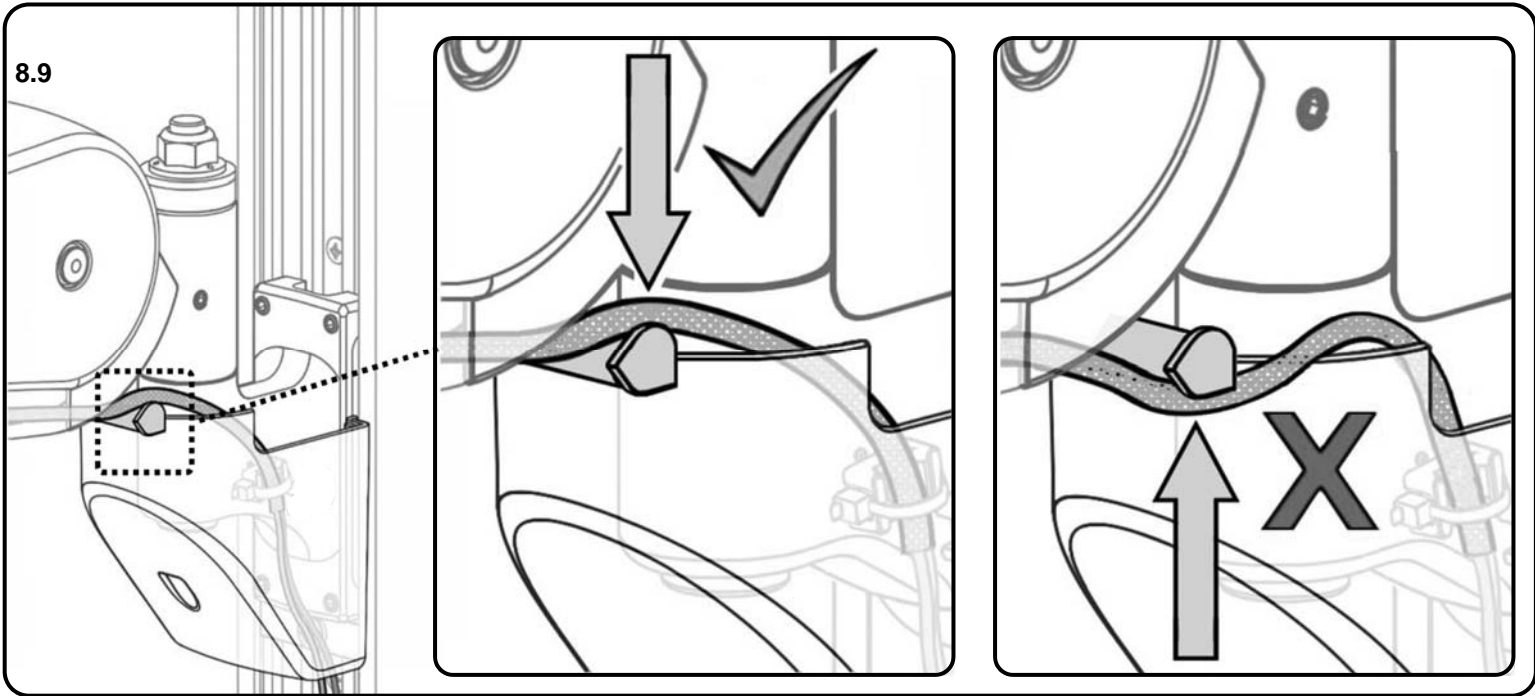
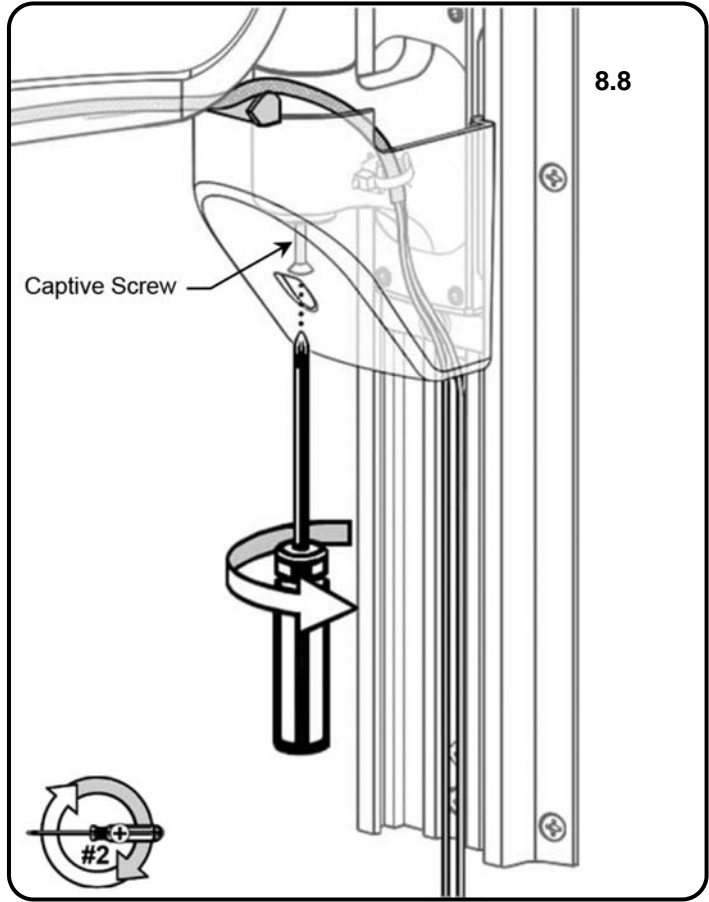
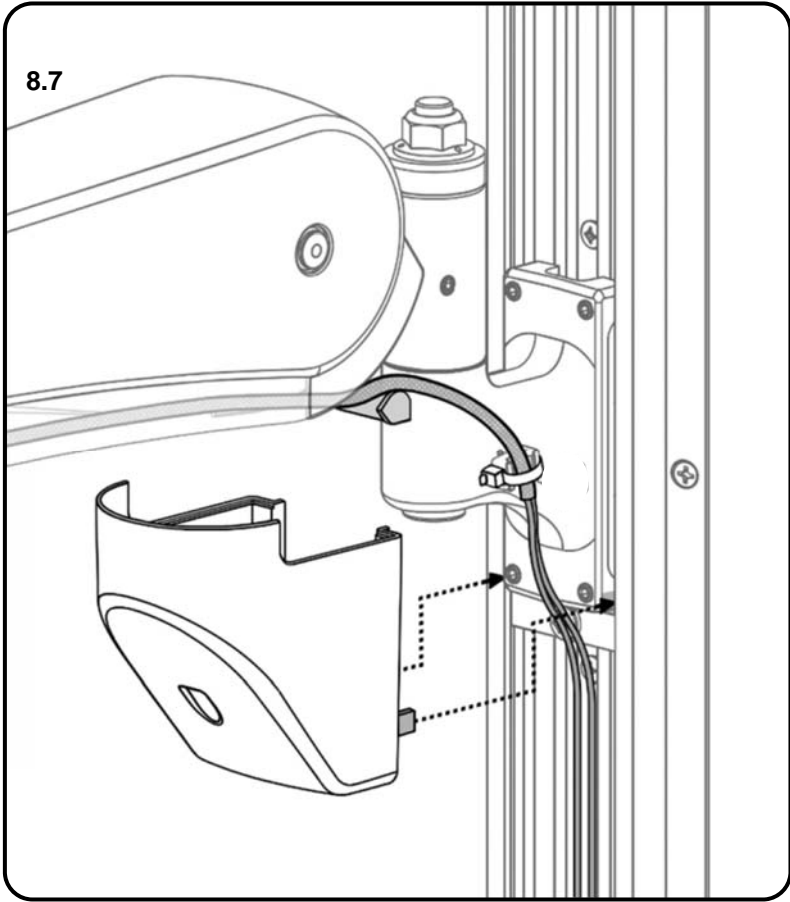

8.10

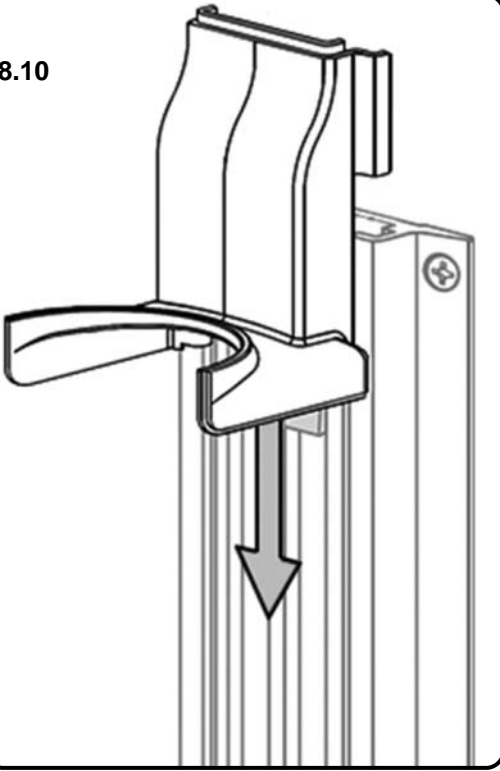

8.11

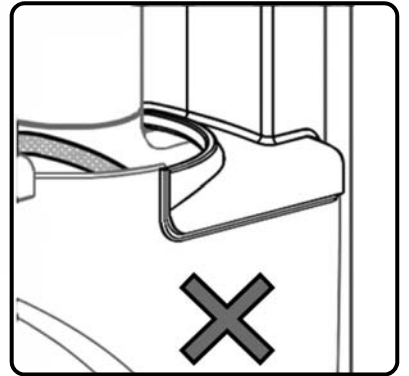
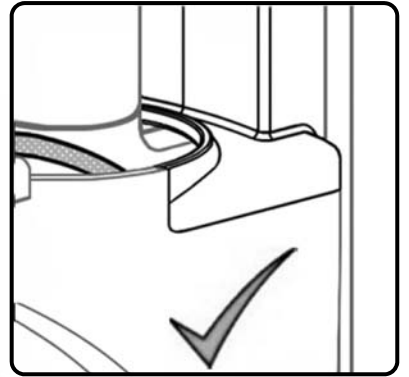
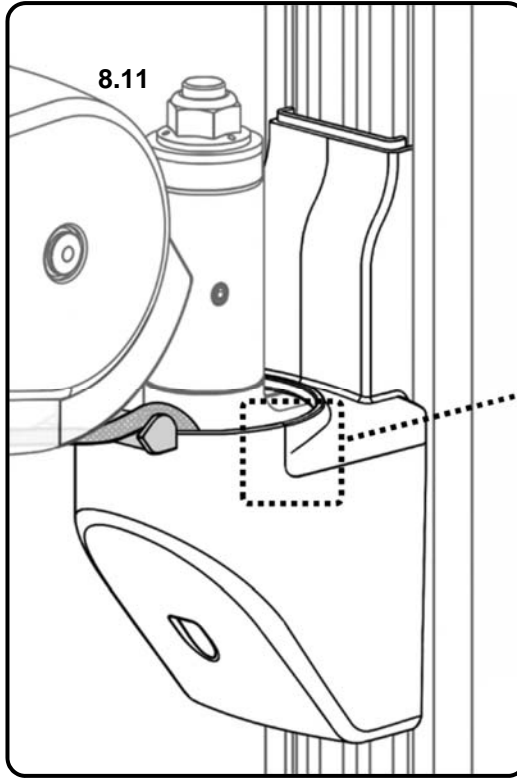

8.12

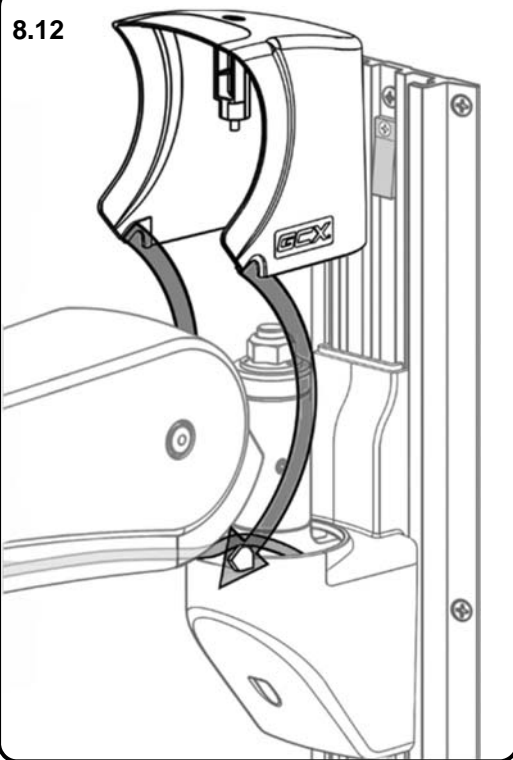

8.13

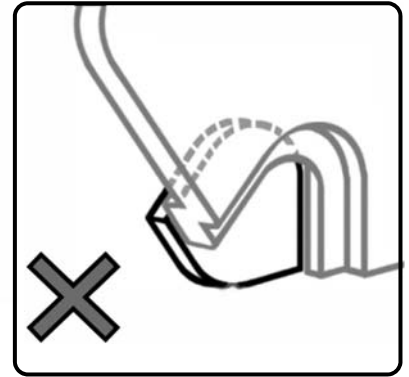
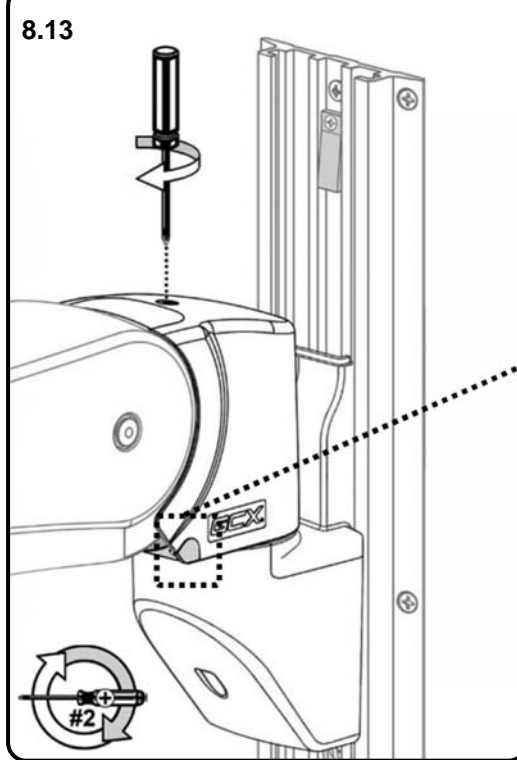

8.14

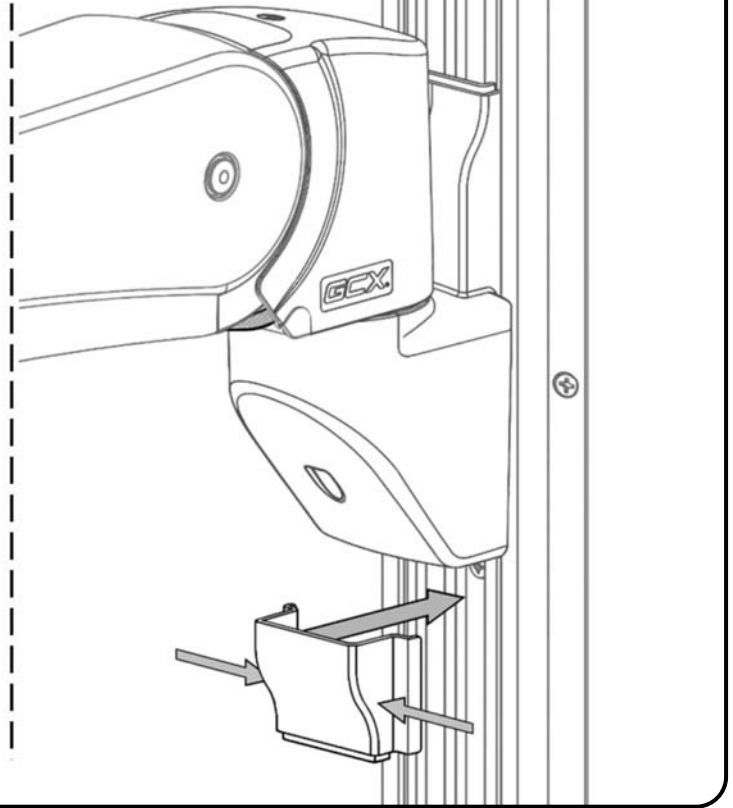
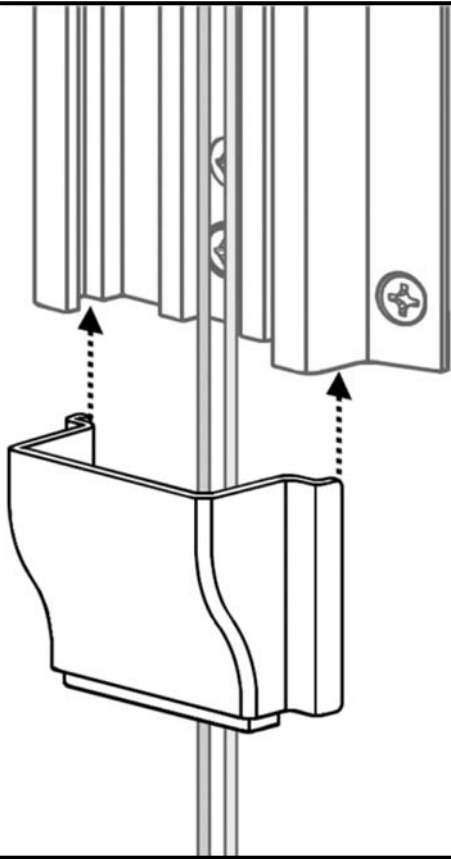

8.15

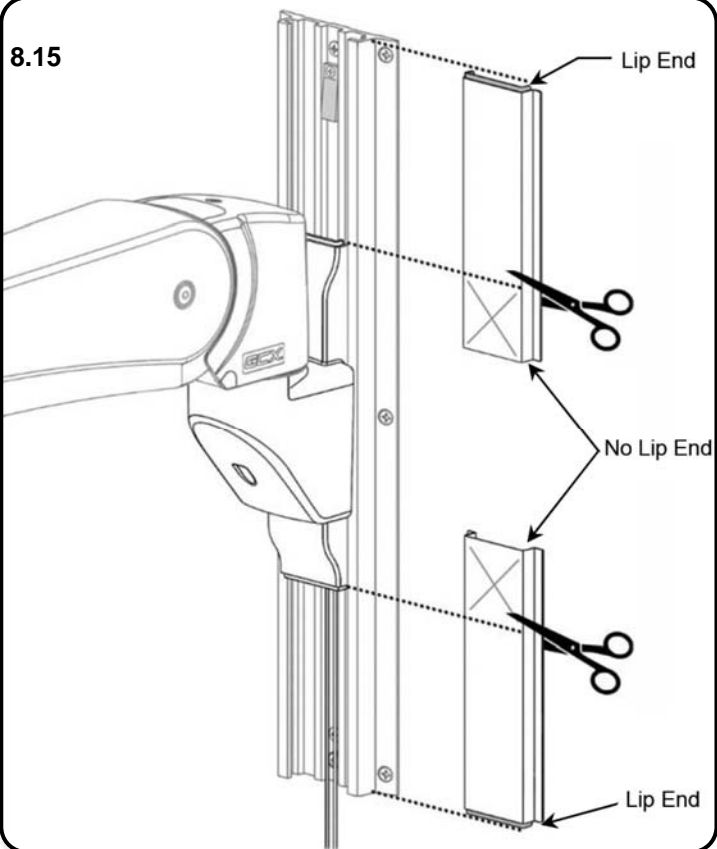

8.16

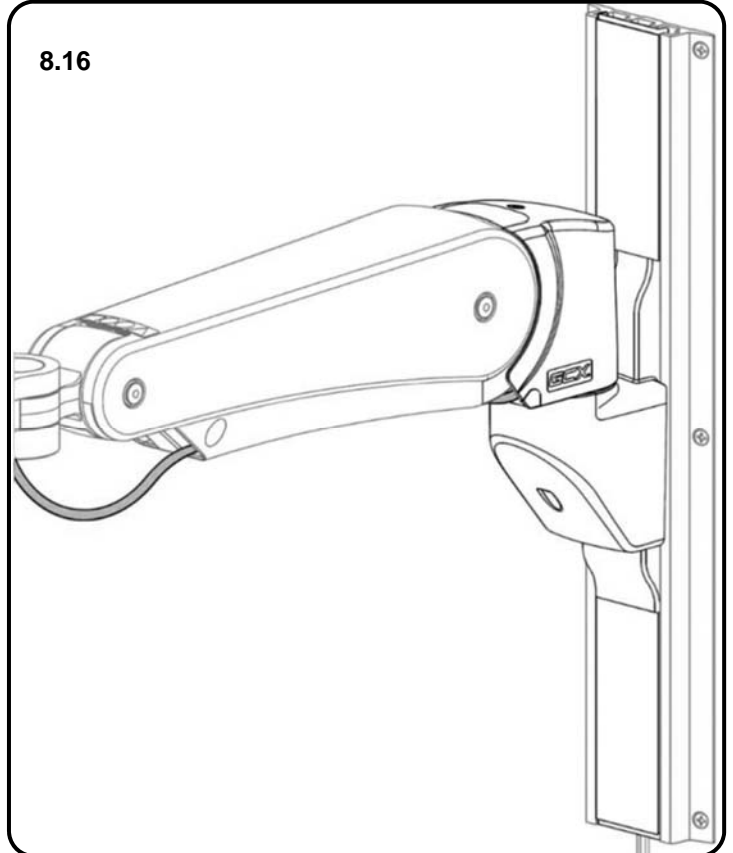

## 9.0 Routine Maintenance

**The Arm must be inspected and maintained at least once a year.**

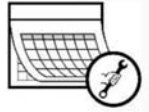

	<b>Routine Maintenance Check List</b>	<b>Section</b>
Counterbalance	With the device mounted, move the arm through its entire vertical range of motion. The load should maintain its position at every point in the travel of arm. If necessary, the counterbalance mechanism may be adjusted.	7.1
Swivel	Grasp the mounted device and swivel it from side to side. The device should swivel with some tension or resistance, not loosely. If necessary, the swivel tension may be adjusted.	7.2
Pivot	Grasp the Arm and pivot it from side to side at the rear attachment. The arm should pivot with some tension or resistance, not loosely. If necessary, the pivot tension may be adjusted.	7.3
Hardware	Inspect fasteners for looseness. Tighten as required for optimal operation and safety.	5.2,5.4

## 10.0 Cleaning the VHM-P Arm

The Arm may be cleaned with most mild, non-abrasive solutions commonly used in the hospital environment (e.g. diluted bleach, ammonia, or alcohol solutions).

The surface finish will be permanently damaged by strong chemicals and solvents such as acetone and trichloroethylene.

Steel wool or other abrasive material should never be used.

Damage caused by the use of unapproved substances or processes will not be warranted. We recommend testing any cleaning solution on a small area of the arm that is not visible, to verify compatibility.

Never submerge or allow liquids to enter the arm. Wipe any cleaning agents off of the arm immediately using a water-dampened cloth. Dry the arm thoroughly after cleaning.

**CAUTION:** GCX makes no claims regarding the efficacy of the listed chemicals or processes as a means for controlling infection. Consult your hospital's infection control officer or epidemiologist. To clean or sterilize mounted instruments or accessory equipment, refer to the specific instructions delivered with those products.

## 11.0 Troubleshooting the VHM-P Series Arm

Symptom	Possible Cause	Remedy
Mounted device does not appear level or parallel to the floor.	Channel not plumb. Check with level.	Adjust Channel to plumb, or reinstall Channel.
	Weight of device not compatible with Load Rating of the Arm.	Mount device on arm with compatible Load Rating (section 3.0).
	Swivel hardware loose.	Adjust Swivel Tension Nut (section 7.2).
	Pivot hardware loose.	Adjust Pivot Tension Nut (section 7.3).
	Mounting surface (e.g. wall, side of anesthesia machine, etc.) not structurally sound (does not hold mounting hardware).	Mounting surface must be reinforced or Channel must be relocated.
	Channel loose at mounting surface.	Check for plumb and tighten, or relocate (reinstall) Channel.
Mounted device drifts up or down.	Arm not counterbalanced correctly for weight of the device.	Perform counterbalance adjustment (section 7.1).
	Weight of mounted device not compatible with Load Rating of Arm.	Use arm with compatible Load Rating (section 3.0).
Mounted device difficult to move up or down.	Arm not counterbalanced correctly for weight of mounted device.	Perform counterbalance adjustment (section 7.1).
Arm pivots too freely.	Pivot tension is too loose.	Adjust Pivot Tension (section 7.3).
Arm is difficult to pivot.	Pivot tension is too tight.	
Device swivels too freely.	Swivel tension is too loose.	Adjust Swivel Tension (section 7.2).
Device is difficult to swivel.	Swivel tension is too tight.	
Arm inadvertently slides down Channel.	Set Screws (4) in Slide are loose.	Reposition Arm, tighten set screws in slide, and secure adjustable stop (section 5.2 and 5.4).
	Adjustable Stop is loose or missing.	Install or secure adjustable stop (section 5.2).

## **Routine Maintenance**

Periodically inspect all fasteners associated with the mounting assembly. Tighten or Adjust as necessary for optimal operation and safety.

## **Cleaning the Mounting Assembly**

The mounting assembly may be cleaned with most mild, non-abrasive solutions commonly used in the hospital environment (e.g. diluted bleach, ammonia, or alcohol solutions).

The surface finish will be permanently damaged by strong chemicals and solvents such as acetone or trichloroethylene.

Steel wool or other abrasive material should never be used.

Damaged caused by the use of unapproved substances or processes will not be warranted. We recommend testing of any cleaning solution on a small area of the mounting assembly that is not visible to verify compatibility.

Never submerge or allow liquids to enter the mounting assembly. Wipe any cleaning agents off the mounting assembly immediately using a water-dampened cloth. Dry the assembly thoroughly after cleaning.



**CAUTION:** GCX makes no claims regarding the efficacy of the listed chemicals or processes as a means for controlling infection. Consult your hospital's infection control officer or epidemiologist. To clean or sterilize mounted devices or accessory equipment, refer to the specific instructions delivered with those products.