

## Installation Guide

### Spacelabs 94267 & 91393 VHM Wall Mount

The purpose of this guide is to:

- Describe assembly of the Wall Mount (page 2).
- Describe Routine Maintenance (page 3).



### Parts Reference

The following parts are included in this installation kit :

Item #	Description	Qty
1	VHM Wall Mount Arm	1
2	Channel Cover (not shown)	1
3	1/2" Socket Wrench	1
4	1/8" Hex Wrench	1



### Tools Required:

- Phillips screwdriver (not provided)
- 1/2" Socket Wrench (provided)
- 1/8" Hex Wrench (provided)

## Installing Wall Mount Arm

1. Insert the VHM Wall Mount Arm into top of Wall Channel and slide to mounting position. Using a 1/8" Hex Wrench, tighten the (4) Set Screws to secure Wall Mount Arm (below right).

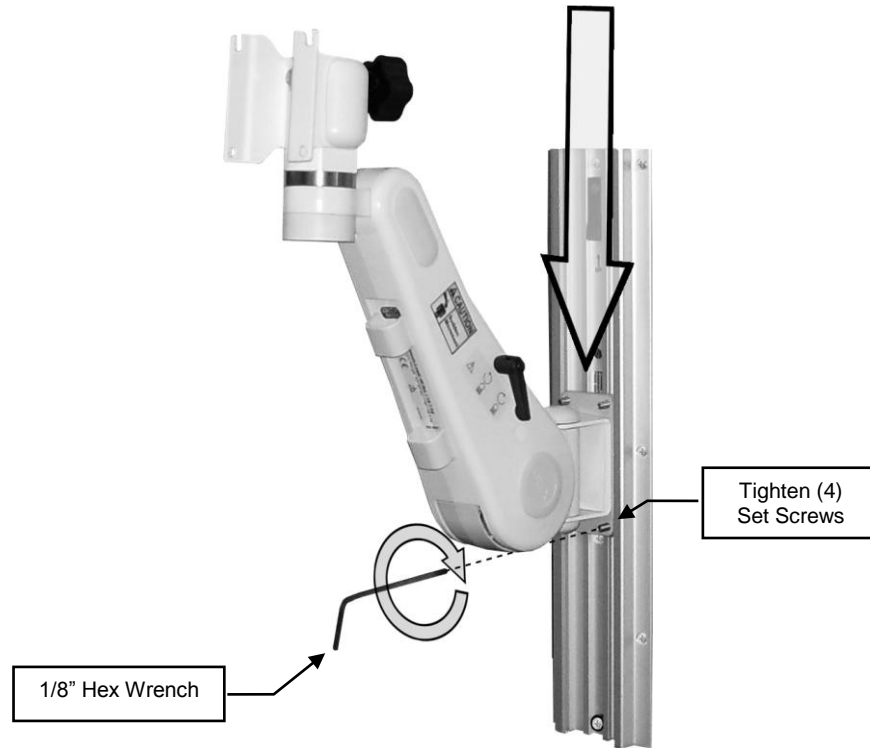

## Mounting the 94267 and 91393

**Installation Note:** M6 Mounting Screws supplied by Spacelabs.

1. Thread (2) screws into the (2) upper threaded mounting holes on the Monitor/Display Mount leaving 1/2 of the thread exposed. Slide Monitor/Display Mount down onto Wall Mount Arm as shown (below left).
2. Thread (2) screws into the lower mounting holes as shown (below right). Using a Phillips screwdriver, tighten all screws.



## Tilt Adjustment and Swivel Tension

**Tilt Adjustment** is achieved by tightening or loosening the Adjustment Knob on the back of the Tilt Swivel Assembly (below left).

**Swivel tension** can be adjusted by tightening or loosening the locknut on the bottom of the Tilt Swivel Assembly with a 1/2" wrench (below right).

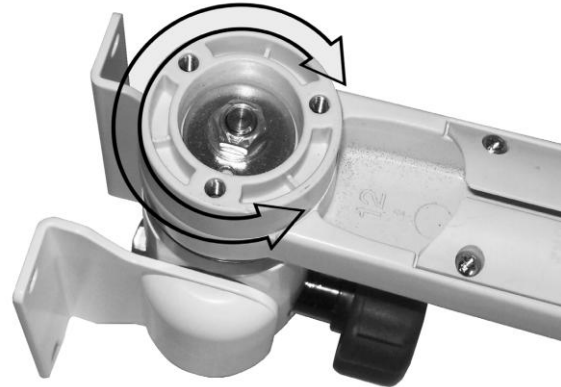
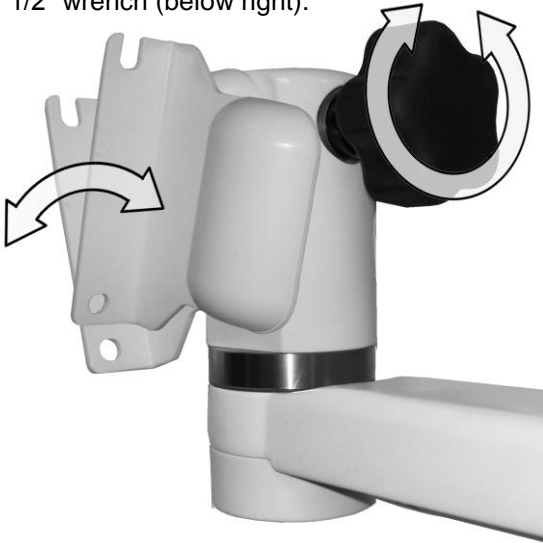

### Installing the Wall Channel Cover

Install the Wall Channel Cover in accordance with the *Channel Cover Installation Guide (DU-UT-0001-20)*.

### Routine Maintenance

Periodically inspect all fasteners associated with the mounting system. Tighten as necessary for optimal operation and safety.

### Cleaning the Mounting Assembly

1. The mounting assembly may be cleaned with most mild, non-abrasive solutions commonly used in the hospital environment (e.g. diluted bleach, ammonia, or alcohol solutions).
2. The surface finish will be permanently damaged by strong chemicals and solvents such as acetone and trichloroethylene.
3. Do not use steel wool or other abrasive material to clean the mounting assembly.
4. Damage caused by the use of unapproved substances or processes will not be covered by warranty. We recommended that you test any cleaning solution on a small area of the mounting assembly that is not visible to verify compatibility.
5. Never submerge the roll stand or allow liquids to enter the mounting assemblies. Wipe any cleaning agents off the mounting assembly immediately using a water-dampened cloth. Dry all mounting assemblies thoroughly after cleaning.

**CAUTION:** GCX makes no claims regarding the efficacy of the listed chemicals or processes as a means for controlling infection. Consult your hospital's infection control officer or epidemiologist. To clean or sterilize mounted instruments or accessory equipment, refer to the specific instructions delivered with those products.