

VHM-P (Non-Locking) Variable Height Arm with 8"/20.3cm or 14"/35.6cm Extension and Philips Suspension Front End For Philips IntelliVue MP20/30/40/50/60/70, MX400/450/500/550/600/700/800

Installation Guide

(Refer to qualified personnel)

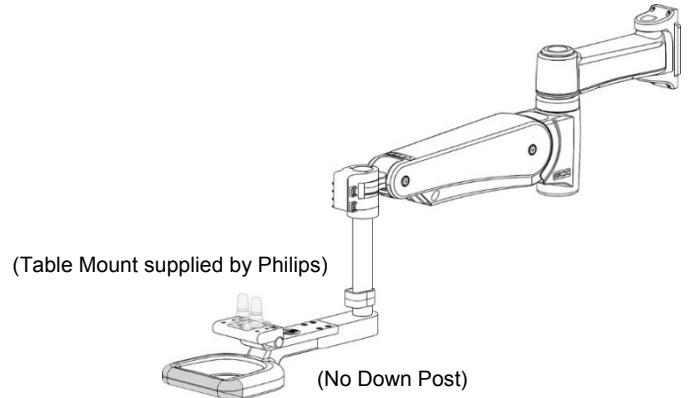
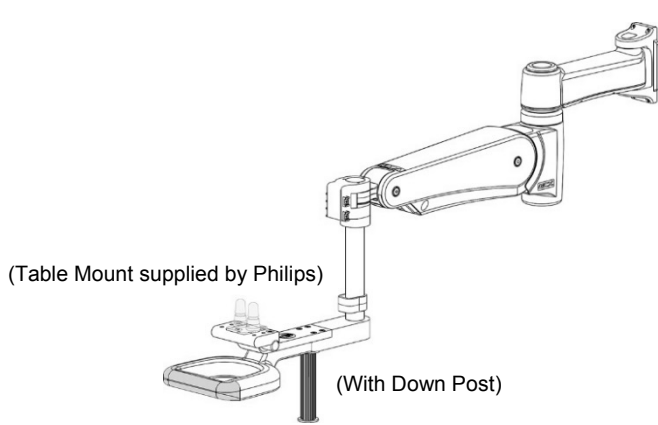

PH-0077-53	8"/20.3cm Extension	MP60/70
PH-0077-54	14"/35.6cm Extension	MX600/700/800



Load Range: 25 - 45 lb / 11.3 - 20.4 kg
Maximum Tilt Weight Limit: 30 lb / 13.6 kg

PH-0079-30	8"/20.3cm Extension	MP20/30/40/50
PH-0079-31	14"/35.6cm Extension	MX400/450/500/550



Load Range: 15 - 30 lb / 6.8 - 13.6 kg

Installation Time

Approximately 10-15 minutes

The purpose of this manual is to describe general installation, operation, and adjustment procedures for the VHM-P Series Arms with Extension. This manual should be used in conjunction with any instrument-specific installation guides. Please read this manual and all instrument-specific installation material before installing or using this product.

Table of Contents

1.0	Parts Reference.....	2
2.0	Tools Required.....	2
3.0	Product Warning / Safety Labels.....	3
4.0	Installation, Operation, and Maintenance Warnings.....	4
5.0	Assemble Suspension Front End	5
6.0	Installing the Arm in Channel	5
7.0	Mounting the Device	6
8.0	Adjusting the Arm	7
9.0	Cable Management.....	9
10.0	Channel Cover Installation.....	13
11.0	Routine Maintenance.....	13
12.0	Cleaning the Arm.....	13
13.0	Troubleshooting the VHM-P	14

1.0 Parts Reference

The following parts and hardware are included and labeled accordingly:

Item #	Description	Quantity
BOX 1		
1	VHM-P Channel Mount Arm with Extension	1
2	Cable Cover	1
3	Lower Pivot Cover	1
4	Fixed Mount Spacer (For Philips Device w/o Table Mount Interface)	1
5	Cable Tie	8
6	Adjustable Stop	1
7	30.5" (77.5 cm) Cable Sleeve	2
8	1/2" (13mm) x 3/4" (19mm) Wrench	1
9	16" (40.6 cm) Channel Cover	1
10	1/8" Hex Wrench (<i>not shown</i>)	1
11	5/32" T-Handle Hex Wrench (<i>not shown</i>)	1
12	M6 x 8mm Flat Head Machine Screws (FHMS) (<i>not shown</i>)	2
13	M6 x 12mm (FHMS) (<i>not shown</i>)	1
14	M6 x 16mm Pan Head Machine Screw (PHMS) (<i>not shown</i>)	2
BOX 2		
15	a Suspension Front End Assembly with Down Post (<i>PH-0077-53 and PH-0077-54 only</i>)	1
	b Suspension Front End Assembly (<i>PH-0079-30 and PH-0079-31 only</i>)	1
16	Cable Clip	1
17	10-32 x 7/8" Socket Head Cap Screw SHCS (<i>not shown</i>)	3
18	5/32" Ball End Hex Wrench (<i>not shown</i>)	1

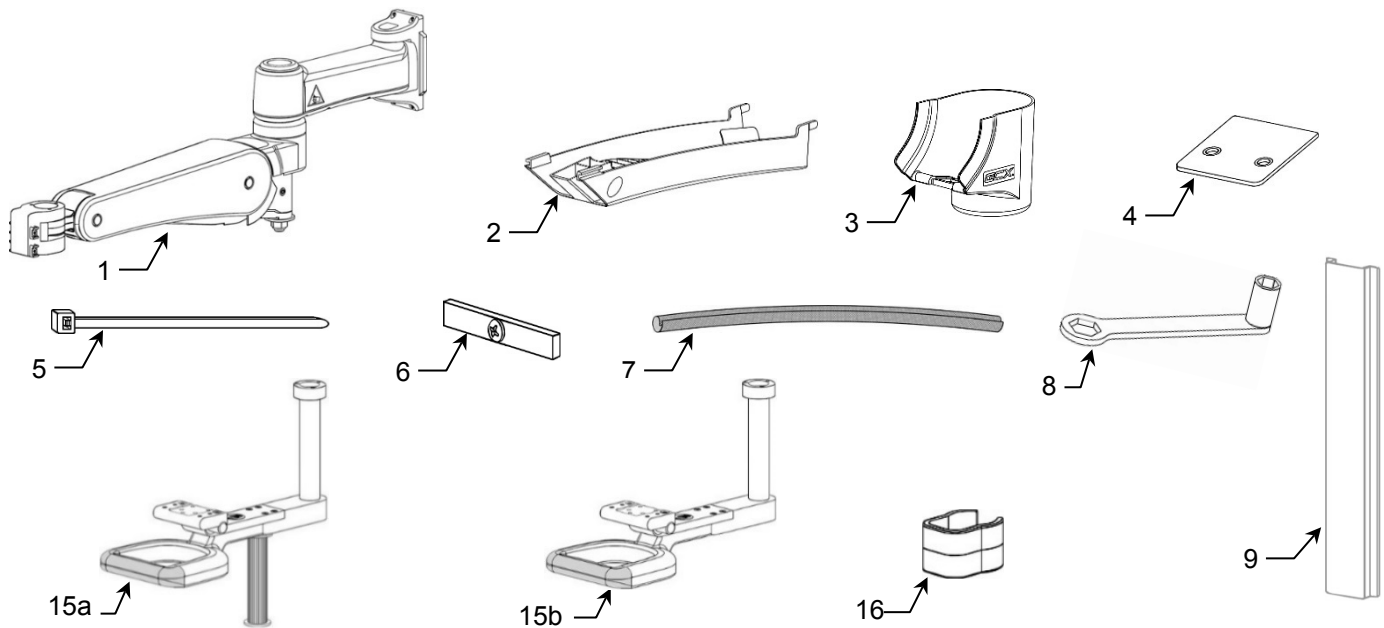

2.0 Tools Required

The tools listed below are required to install and adjust the Arm.

Provided

1. 1/8" Hex Wrench
2. 5/32" Hex Wrench
3. 1/2" (13mm) / 3/4" (19mm) Wrench

Not Provided

4. #2 Phillips Screwdriver
5. Scissors, utility knife or similar cutting tool
6. Wire Cutters (for cable ties)

3.0 Product Warning / Safety Labels

Safety Label Locations (VHM-P Series Arms)

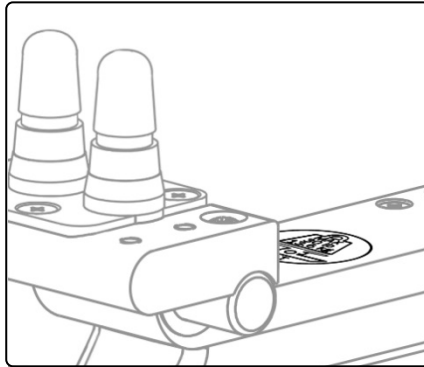
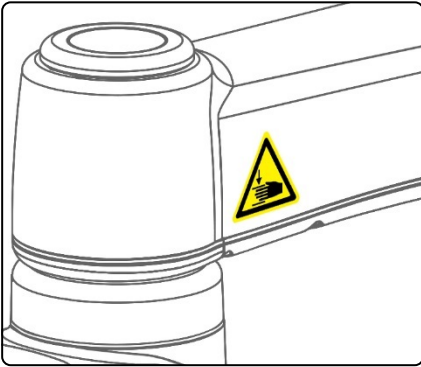
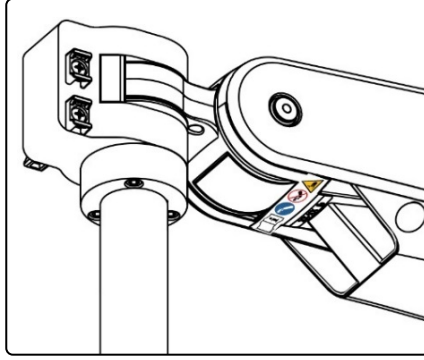
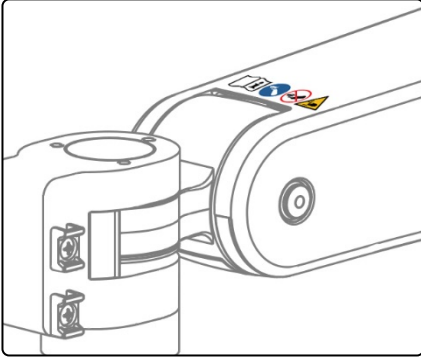

Refer to Installation Guide for additional information.



Remove the Device only when the Arm is at the highest position.



Do not remove device when arm is in a lowered position.



Potential pinch point that may cause personal injury.



Maximum weight for mounting plate with tilt function.

Counter Balance Load Range:
25 - 45 lb / 11.3 - 20.4 kg
or
15 - 30 lb / 6.8 - 13.6 kg

4.0 Installation, Operation, and Maintenance Warnings

This section contains warnings regarding the installation, operation, and maintenance of the Arm. This section must be read in its entirety before installing, operating, and maintaining the Arm. Failure to follow these warnings may result in damage to equipment or injury to personnel.



Warnings

- Do not position the Arm or mounted Device above a patient. Note that the Arm has a wide range of motion both up/down and side to side. Please consider carefully the Device being mounted and the proximity of the mounting assembly to other equipment, hospital personnel, and the patient. GCX recommends that the hospital's risk management personnel verify that the application is appropriate prior to installation and use of this Arm.
- Before the Arm is channel mounted, verify that the channel has been installed and approved in accordance with the channel installation guide. Documents are available on our website: [www.gcx.com / Support](http://www.gcx.com/Support).
- Ensure that the total weight of the devices being mounted does not exceed the load rating of the Arm. Check the bottom surface of the Arm for the load range label. Refer to Section 3.0.
- Do not use power tools to make any adjustments on Arm.
- The mounted device or arm may move suddenly due to normal wear or improper adjustment of the tilt, swivel, and pivot functions (see Sections 8.2, 8.3, 8.4 and 8.5), improper counterbalance (Section 8.1) or ultimately, gas spring end of life. The gas spring has a limited life span and will lose some strength over a long period of time. **The Arm must be inspected and maintained at least once a year.** This inspection must include the steps outlined in Section 11.0
- Failure to periodically inspect and adjust the Arm as instructed may result in damage to equipment or injury. If you are unable to adjust the arm or require service, contact GCX technical support at 800.228.2555 or + 1 707.773.1100.
- Note that the VHM-P Arm has a wide range of motion both up/down and side to side. Please consider potential pinch Points that may cause personal injury.

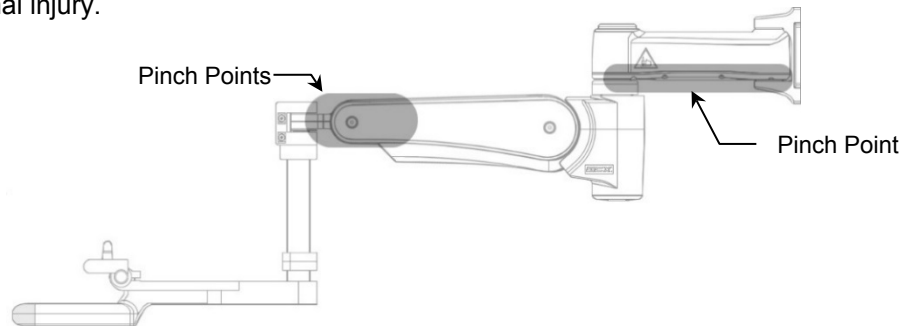

- Remove the Device only when the Arm is at the highest position. Due to the counter balance function, the Arm will naturally rise to the highest position when weight is removed. This can happen suddenly if the weight is removed at any height other than the highest point.

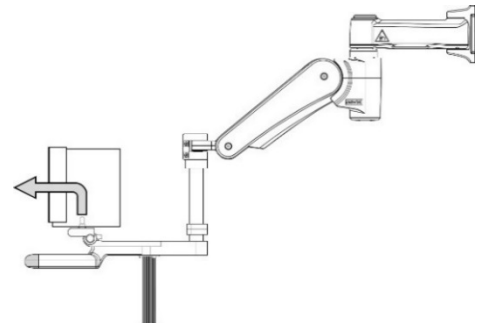
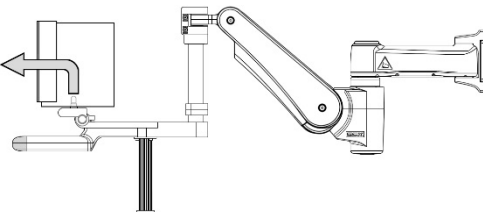

- **CAUTION: For MX600/700/800 - It is possible to position the device so there is potential for interference between the device and the Arm. Regardless of model number, ensure the device mounting locking mechanism is properly engaged at all times.**
- Due to risk of personal injury or damage to the Arm, the Arm housing must never be disassembled by non-GCX personnel. Failure to comply will void the warranty.

5.0 Assemble the Suspension Front End

Using a 5/32" hex wrench, securely fasten the Suspension Mount Front End to the VHM-P Arm with three the provided #10-32 x 7/8" SHCS as shown. The ball end of the provided 5/32" hex key will facilitate starting the screws. Use the leverage of the long end of the hex wrench for final tightening.

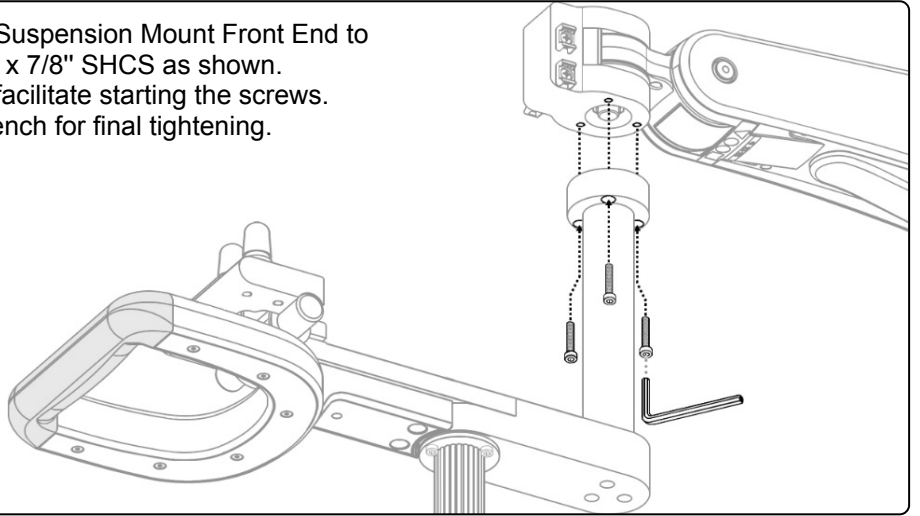

6.0 Installing the Arm in Channel

 Before mounting the Arm, verify that the channel has been installed and approved in accordance with the channel installation guide included with the channel.

6.1 Insert Adjustable Stop into top of channel and slide to desired mounting position.

6.2 Using a #2 Phillips screwdriver, tighten the center screw to secure position.

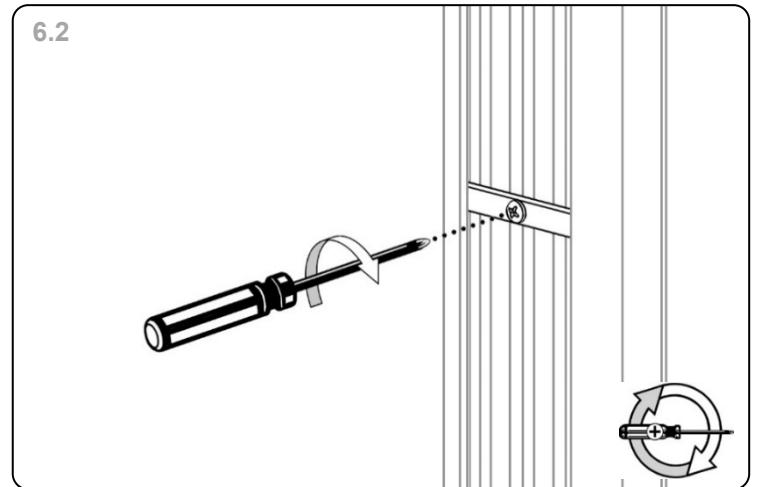
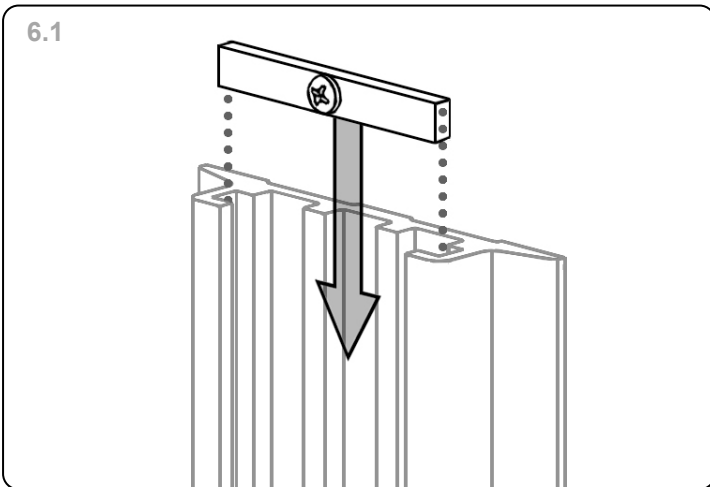

6.3 While supporting the Arm, guide the Slide into the top of the channel and position onto the Adjustable Stop.

6.4 Using the 1/8" hex wrench provided, tighten the (2) upper and the (2) lower set screws in Slide to secure position of Arm. Use the leverage of the long end of the hex wrench for final tightening.

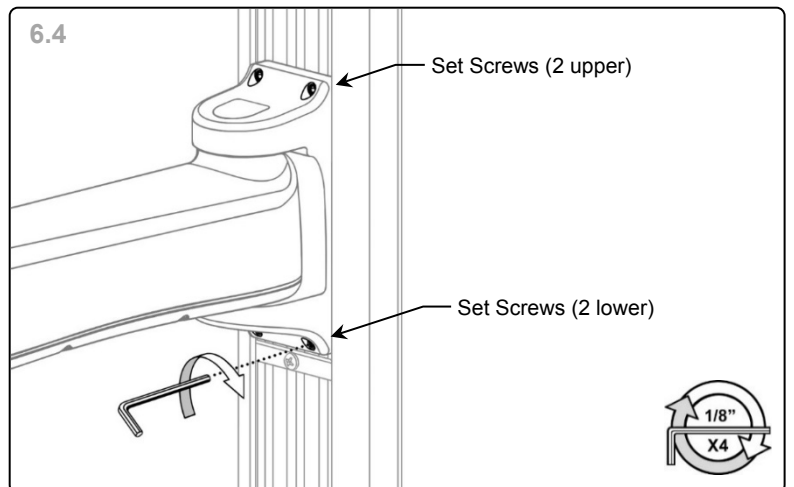
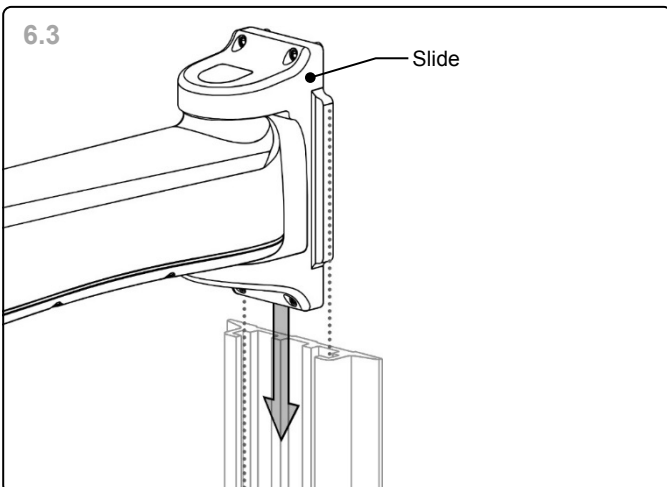

7.0 Mounting the Device



Installation Note for MX600/700/800, MP20/30 Monitors: If equipped with the mounting interface shown in photo (right), mount in accordance with **Step 7.1 Non Table Mount** as shown below. An additional person may be needed to help support the monitor for this Step.



Do not attach Table Mount if Monitor is equipped with this mounting interface.

7.1 Non Table Mount

Fit Spacer into recessed area on top of Mounting Plate (inset). Ensure Spacer remains between Mounting Plate and device. Insert two (2) M6 x 16mm PHMS through bottom of Mounting Plate and thread into mounting holes in bottom of device (right). Alternately tighten screws until monitor is secure.

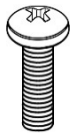
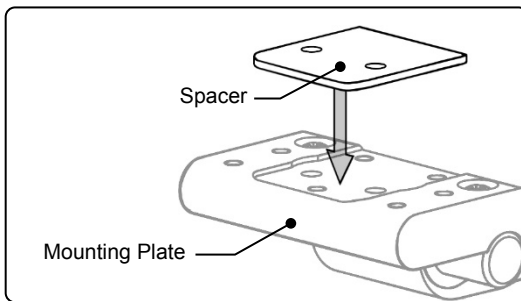

(2) M6 x 16mm PHMS

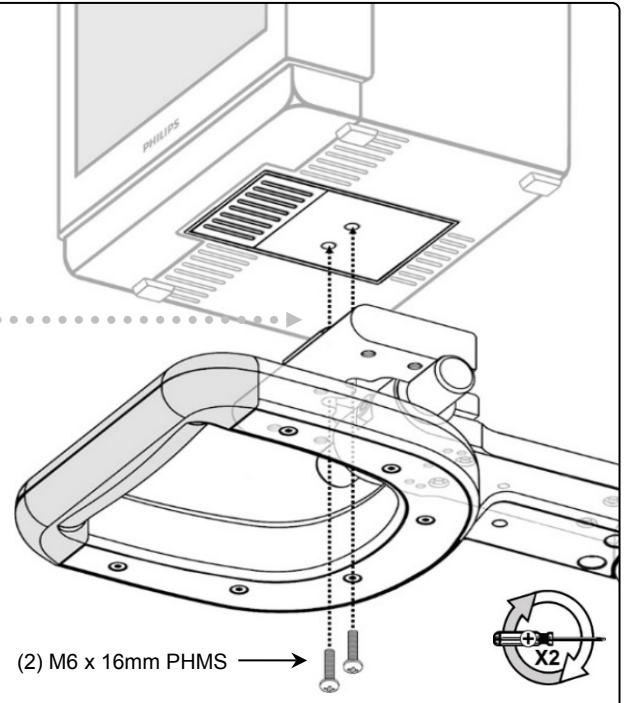

(2) M6 x 16mm PHMS

7.2 Table Mount

(Table Mount supplied by Philips)

Fasten the Philips-supplied Table Mount to Mounting Plate with one (1) M6 x 12mm FHMS and two (2) M6 x 8mm FHMS as shown. Alternately tighten screws until Table Mount is secure. Mount the device in accordance with the Philips Table Mount instruction sheet.



CAUTION: For MX600/700/800 - It is possible to position the device so there is potential for interference between the device and the Arm. Regardless of model number, ensure the device mounting locking mechanism is properly engaged at all times.



(From GCX kit)

(2) M6 x 8mm FHMS

(1) M6 x 12mm FHMS

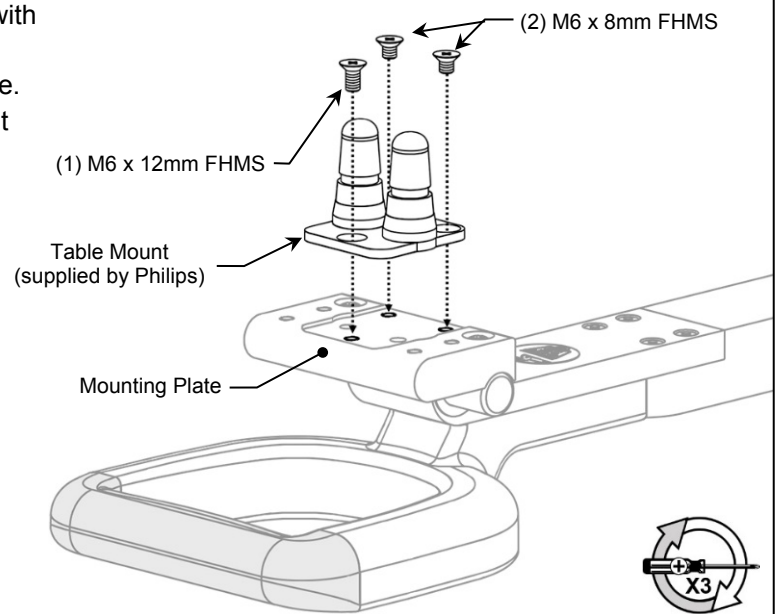

(1) M6 x 12mm FHMS

Table Mount
(supplied by Philips)

Mounting Plate

(2) M6 x 8mm FHMS

8.0 Adjusting the Arm

Installation Note: Adjustments are factory pre-set. However, adjustments to counterbalance, tilt tension, and pivot tensions may all be required to achieve optimal arm performance. Detailed instructions for making adjustments follow in the section below. When properly adjusted the mounted device will move easily throughout the arms full range of motion. Refer to the Routine Maintenance Check List in Section 11 for a quick guide to these functional checks.



Caution: The counterbalance procedure is performed with the device(s) and accessories installed on the Arm. Use caution as it may be necessary to support the weight of the arm/mounted device(s). This process may require an additional person. Use caution while performing this procedure.

8.1 Adjusting Counterbalance

Counterbalance Adjustment – The Counterbalance Adjustment Screw is located under the Arm in front of the center pivot assembly. Grasp the handle and move the Arm to a level horizontal position. Using a 5/32" hex wrench tighten the Counterbalance Adjustment Screw (+) for more counterbalance or loosen (-) for less the. Counterbalance is correctly adjusted when the mounted device can be moved up or down with minimal force and does not rise or fall after releasing the Arm.

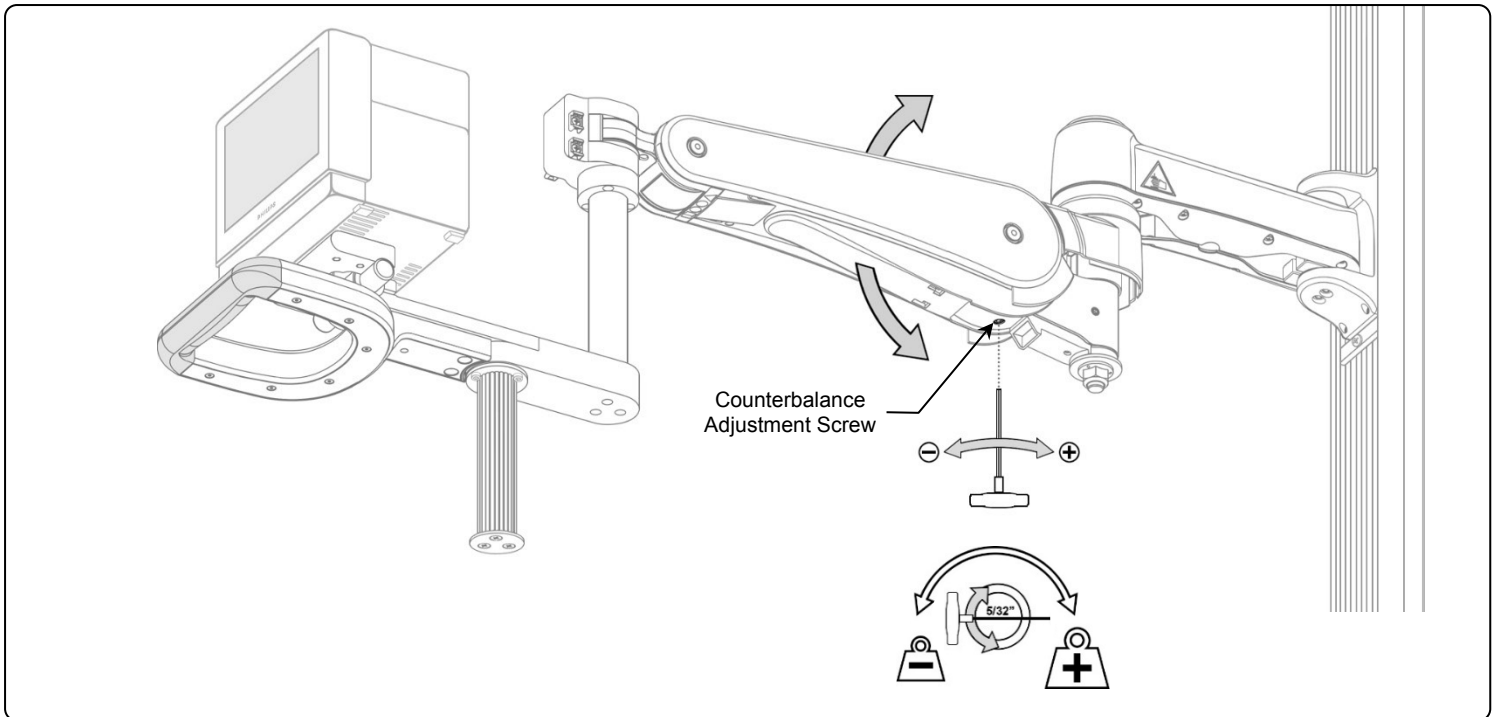

8.2 Tilt Tension Adjustment

1. Using a 5/32 hex wrench, tighten (+) or loosen (-) both Tilt Tension Adjustment Screws until desired Tilt Tension is achieved. Adjustment range is approximately 1/2 turn total.
2. Replace device and check Tilt Tension after adjustment is made and repeat as necessary.

Caution: Do not remove the Adjustment Screws.

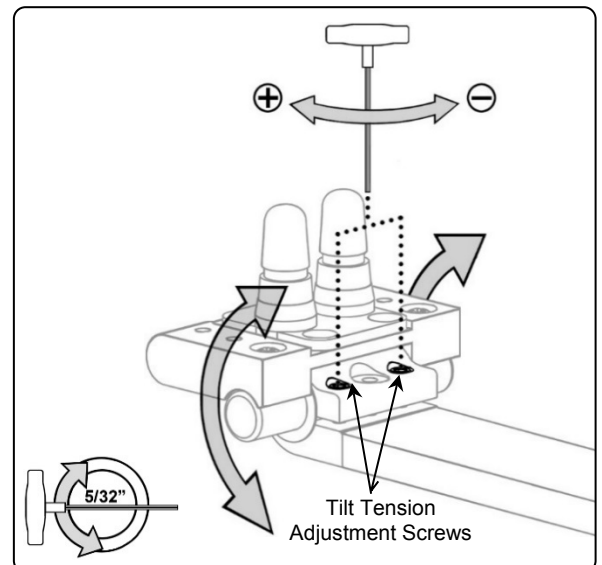

8.3 Swivel Tension Adjustment

1. Remove the mounted device (see Section 7).
2. Reverse the operations of Section 5 to remove the Suspension Front End. Retain the SHCS for re-use.
3. Tighten (+) or loosen (-) the Swivel Tension Nut with a 3/4" (19mm) wrench until desired tension is achieved. Adjustment range is approximately 1/4 turn. **Caution:** Do not remove the Swivel Tension Nut.
4. Reinstall the Suspension Front End per Section 5.
5. Mount the device (see Section 7).

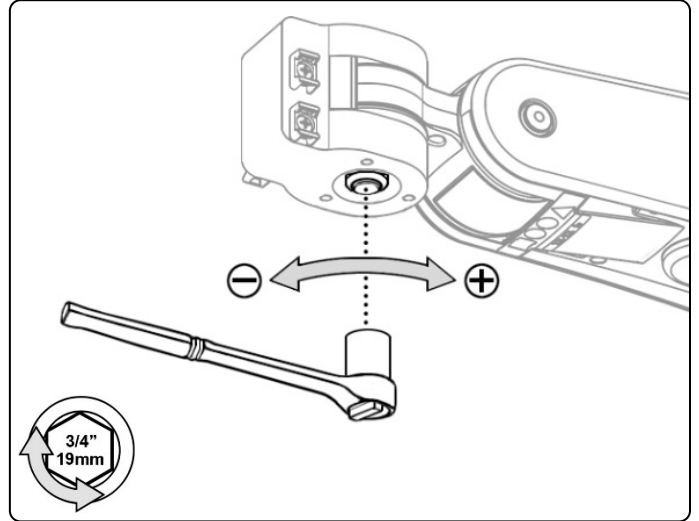
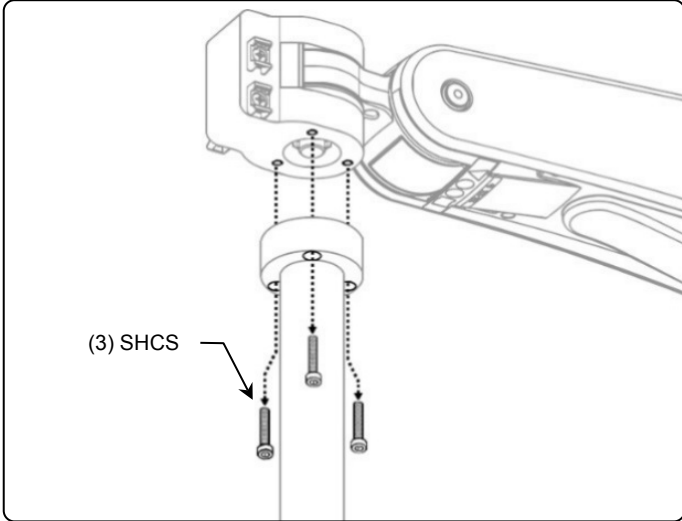

8.4 Center Pivot Tension Adjustment

To adjust the center pivot tension:

1. Tighten (+) or loosen (-) the Pivot Tension Nut with a 3/4" (19 mm) wrench until desired tension is achieved. Adjustment range is approximately 1/4 turn.

Caution: Do not remove the Pivot Tension Nut.

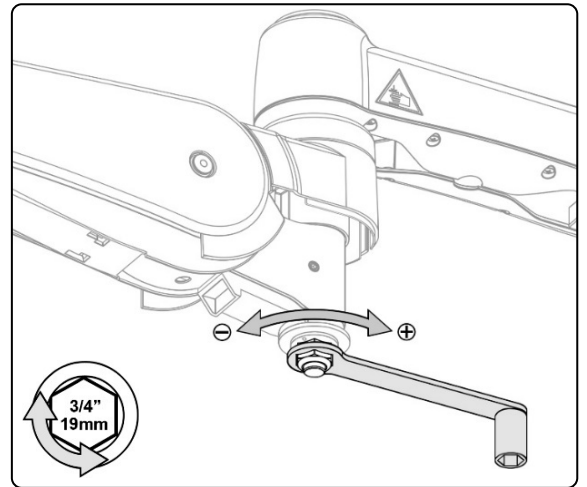

8.5 Rear Pivot Tension Adjustment

To adjust the rear pivot tension:

1. Tighten (+) or loosen (-) the Pivot Tension Screw with a Phillip's screwdriver until desired tension is achieved.

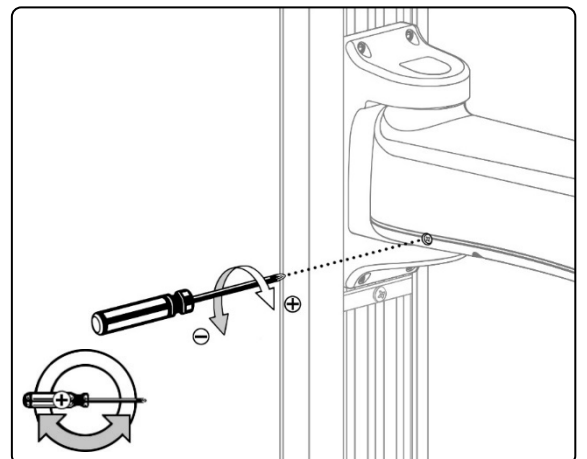

9.0 Cable Management

Cable Routing

Cables are routed from the front of the arm to the Channel for an organized installation. Proper installation of the cabling will ensure the arm operates correctly through its full range of motion and that there are adequate service loops to avoid damage to cables or the mounted device. Cables are anchored at the front of the arm, routed through the covers, through the extension, and then into the channel.

Parts included for cable routing:

Cable Sleeves, 30.5" (77.5cm) long: 2

Cable Clip

Cable Cover

Lower Pivot Cover

Cable Ties: (8ea)

Channel Cover

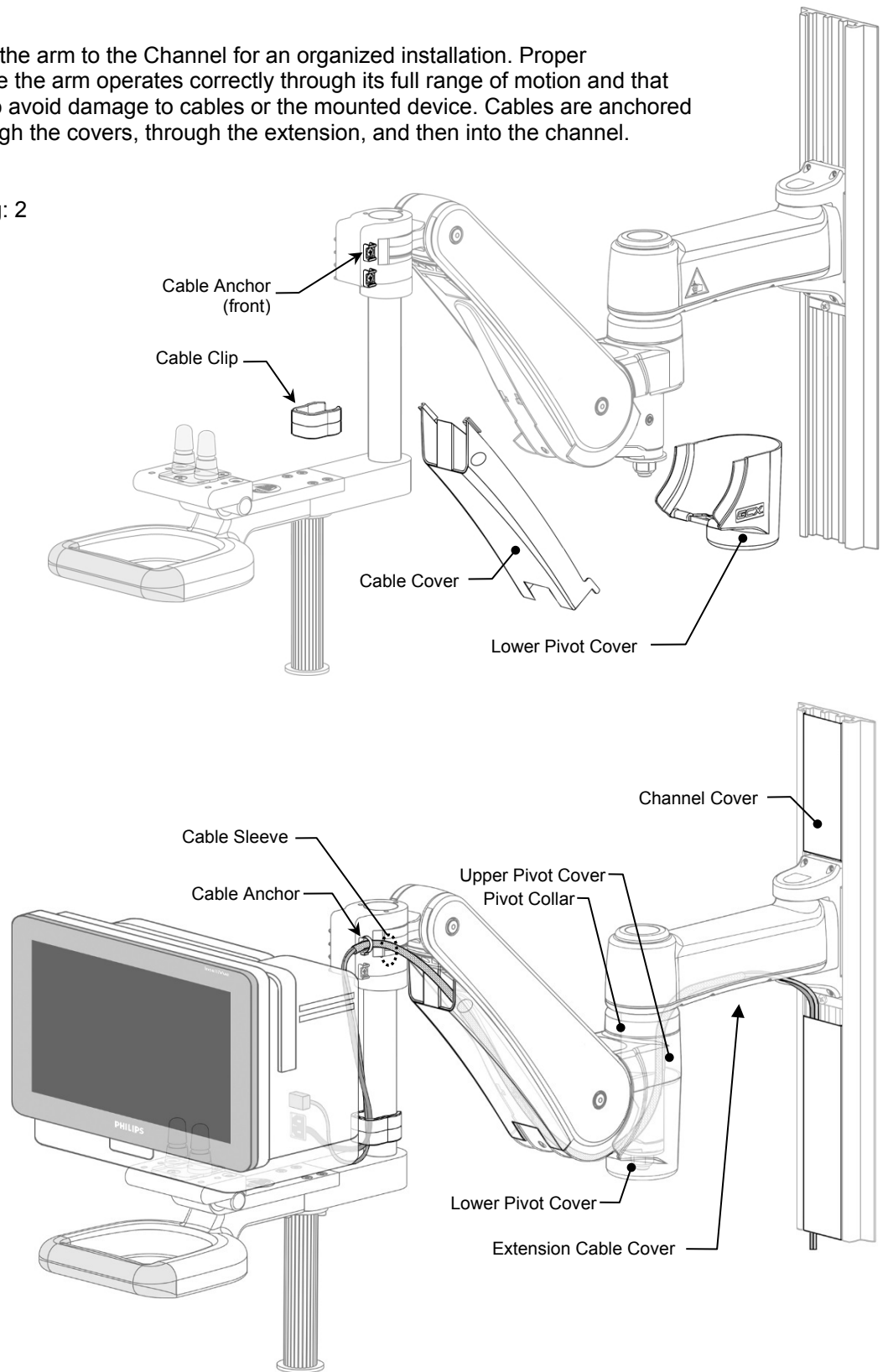

Four (4) Cable Anchors are provided at the front of the arm to secure cables and create the correct service loops. Cables are secured to the anchor points using plastic cable ties included with the Arm. If replacement cable ties are required, standard commercial cable ties can be used.

Two (2) Cable Sleeves are provided to assist in determining Service Loop 2 and to help protect and organize the cables as the Arm is moved throughout its range of motion. Each Cable Sleeve will hold three (3) small cables or one (1) large and one (1) small cable. Use of the Cable Sleeves is optional.

Organize Cables and Determine Cable Service Loop 1

Use of Cable Sleeves is optional but recommended.

Organize the cables. Identify all cables that need to route through the Arm to the Channel and ensure they are long enough. Insert cables into Cable Sleeves if they are being used (see diagram below). Connect all cables to the device and organize them so those on the left side of the device route to the left side anchor points and those on the right side route to the anchor points on right side of the arm.

Determine Service Loop 1. Determine the service loops needed from connections on the device to the front anchor points. Do this by tilting the device to create the longest path from device connections to anchors. Then ensure there is an adequate service loop (length of cable) to avoid damage to cables and connectors or unintended disconnection of cables. Use of the Cable Clip is recommended.

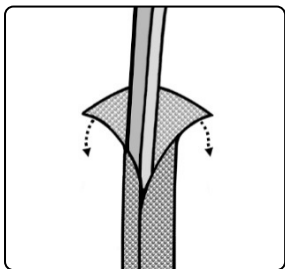
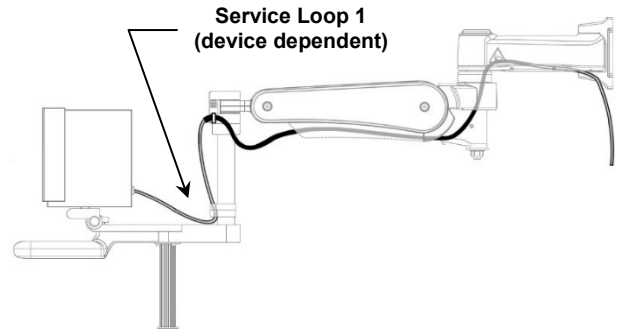

Insert cables into sleeve



CAUTION: Cable sleeve material other than that supplied with the arm (or equivalent) should not be used without verification of function.

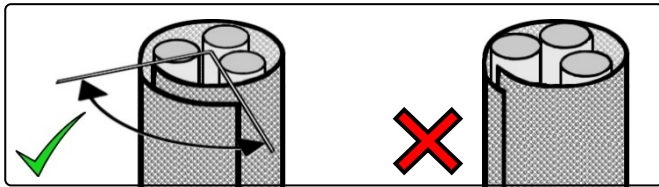

Cable Sleeve must have a 1/4 rotation overlap minimum.

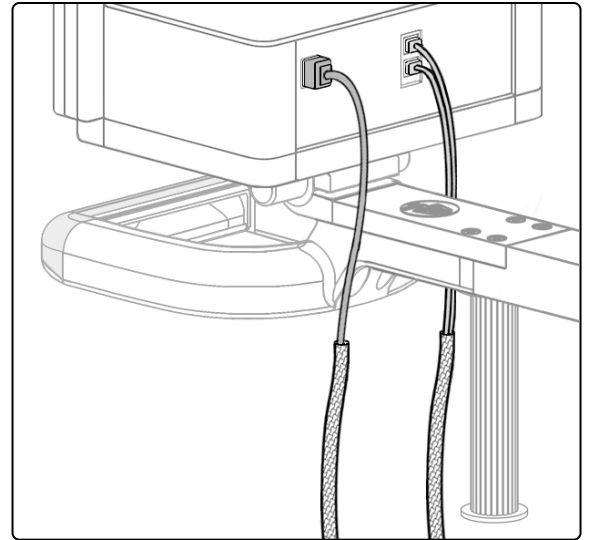

Anchor Cable Bundles. After Service Loop 1 is determined adjust the Cable Sleeve and secure each cable bundle to a Cable Anchor using a cable tie approximately 1/2" (13mm) from the end of the Cable Sleeve. Before securing the cable tie, ensure the service loop to the device is still correct and secure only one bundle per anchor.

Best use of Cable Ties. Position the female receptacle of cable tie against the Arm before tightening. Secure cables by pulling on the cable tie until the cable bundle does not move. Use of pliers may assist in providing enough cable tie tension on the cable bundle. Clip excess length of the cable tie as flush as possible to avoid creation of a sharp edge.

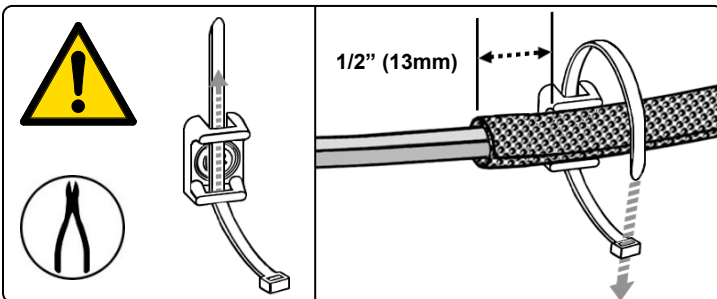

Cable Clip is optional but recommended.

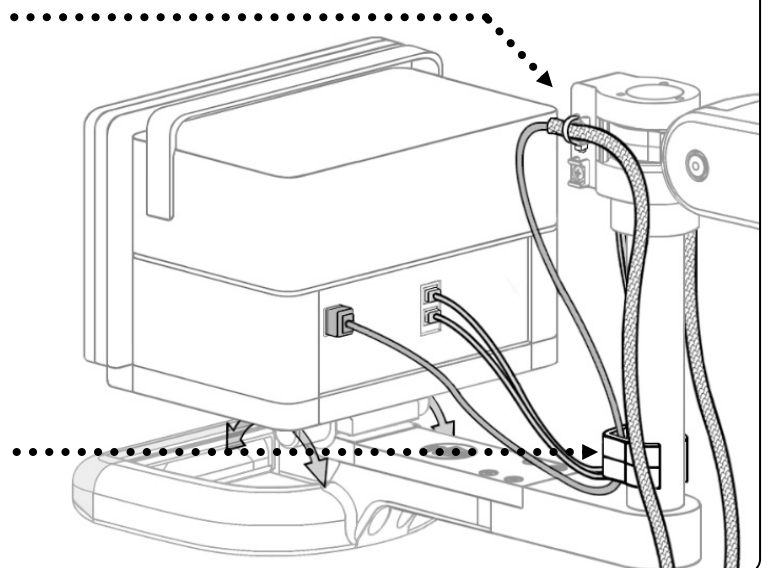
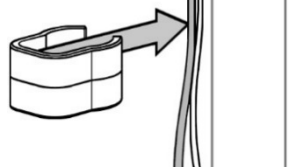

Determine Service Loop 2

Using the provided lengths of cable sleeves will facilitate setting Service Loop 2. The end of Service Loop 2 is simply 1/2in (13mm) from the end of the Cable Sleeve. If the Cable Sleeves are not used, then measure and mark the cables to indicate the end of Service Loop 2. The start of Service Loop 2 is the front Cable Anchor point and the end is approximately 30" (76cm) from the start. The provided Cable Sleeves may serve as a gage to set this length.

The end of Service Loop 2 will be about 1.5"-3.5" (38-89mm) inside the cable cover on the underside of the extension (there is no anchor point at the end of Service Loop 2). See Figure G.

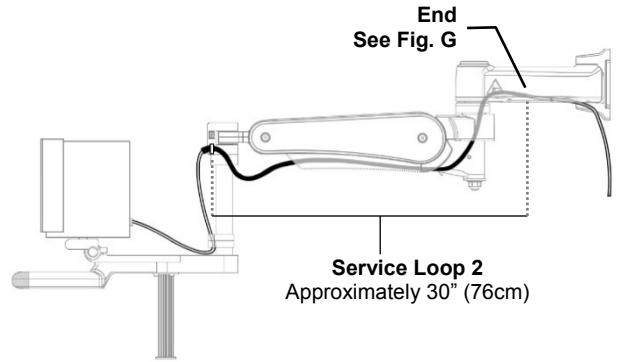

Place the left and right cable bundles into the corresponding track of the Cable Cover (Note: Larger Cables should be placed in first) – **Figure A**. Insert the rear end of the Cable Cover into the two (2) mating slots located below the Arm – **Figure B**.

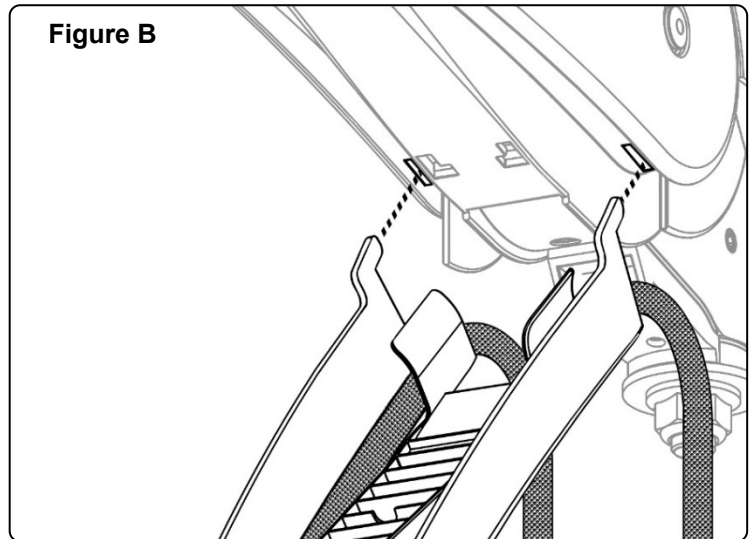
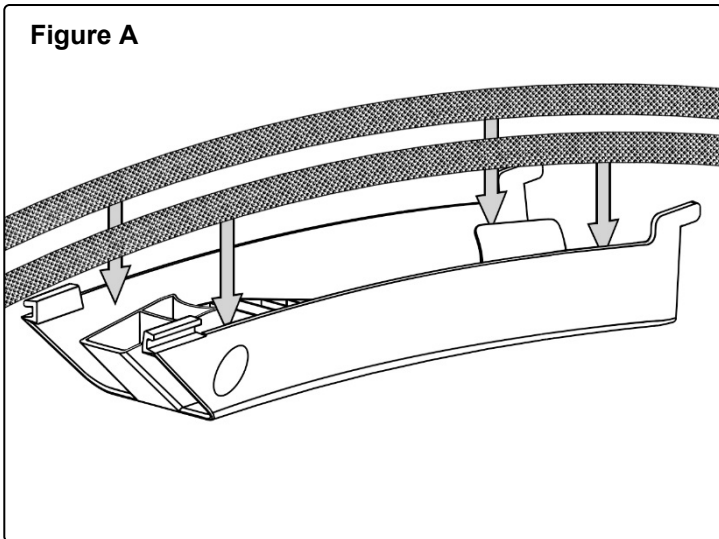

Hinge the Cable Cover up towards the Arm – **Figure C**. Gently squeeze the front of the Cable Cover and insert tabs of the Cable Cover into the mating slots to secure the Cable Cover – Ensure the Cable Cover is engaged in the mating slots – **Figure D**.

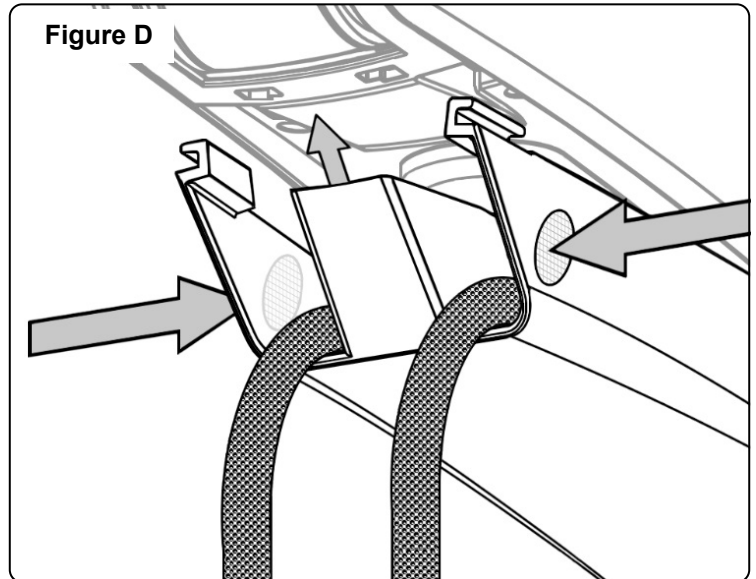
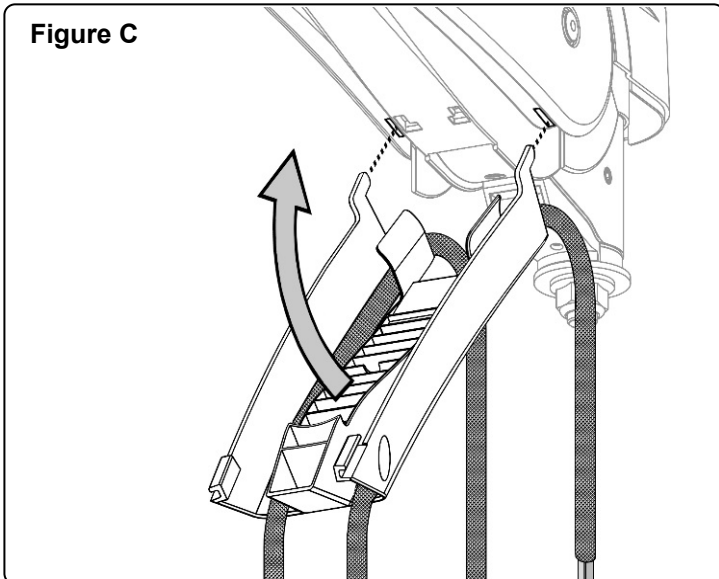

Rotate the Pivot Collar so that the gap is positioned in-line with the seam in the Upper Pivot Cover. Spread the Upper Pivot Cover at the seam and guide the cable bundle upwards through the Pivot Collar gap and into the Extension Cable Cover opening. Feed the cable bundle through the extension to the channel– **Figures E and F.**

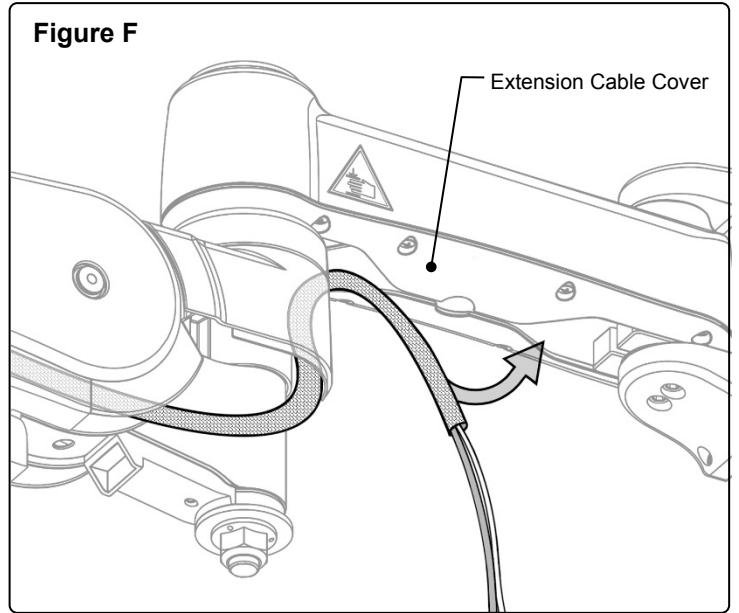
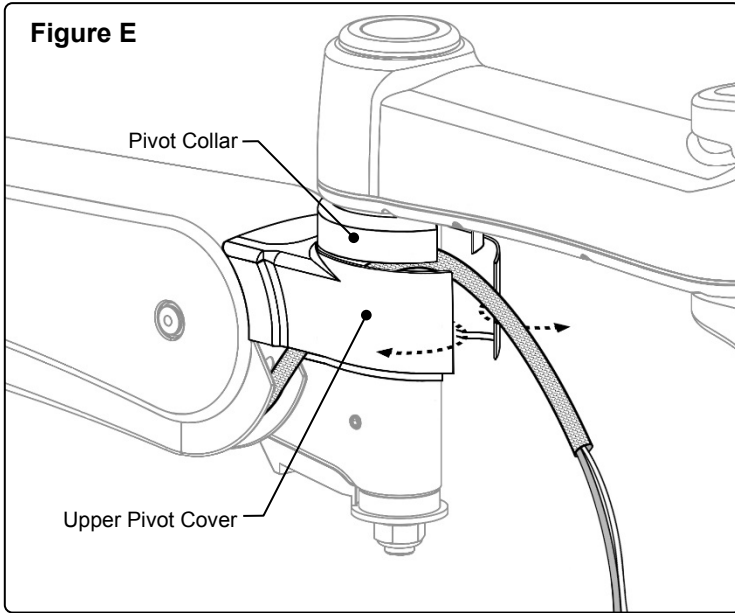

The end of Service Loop 2 (see “Determine Service Loop 2”) should be approximately 1.5”-3.5” (38-89mm) inside the Extension Cable Cover – **Figure G.**

Fit the Lower Pivot Cover in place and thread the captive screw into the threaded mounting hole using a #2 Phillips screw driver. Do not overtighten the screw – **Figure H.** Move the arm through its full range of motion and ensure cables do not bind motion and are not pinched.

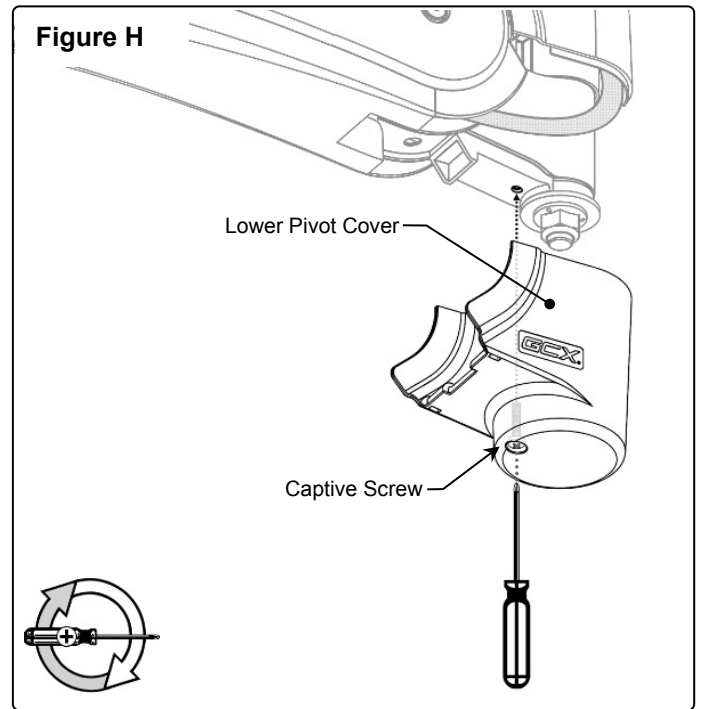
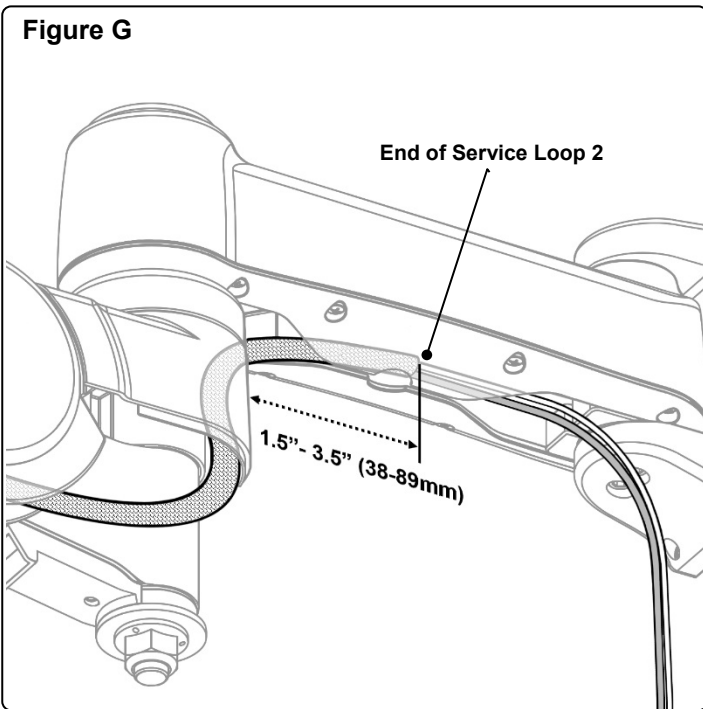

10.0 Channel Cover Installation

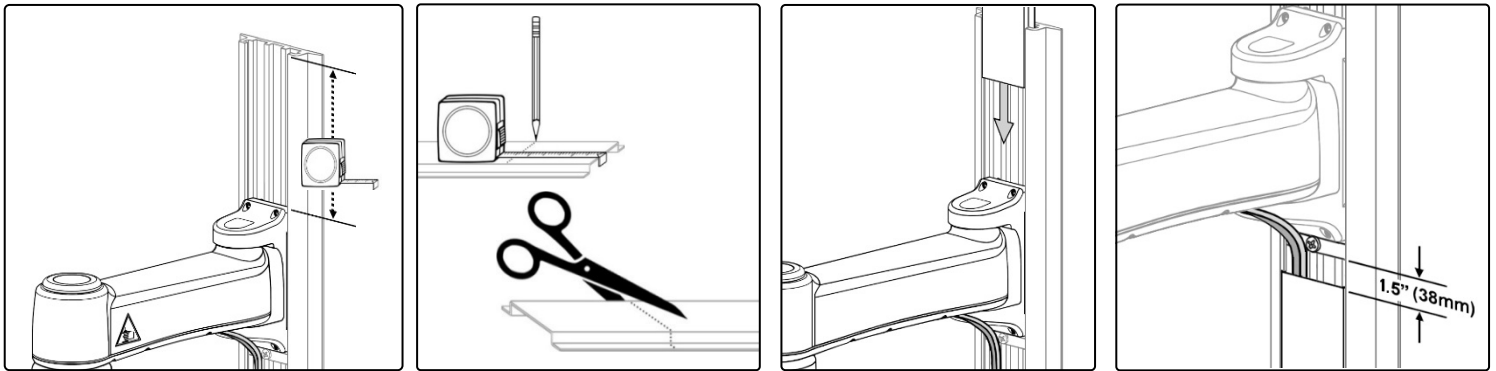

11.0 Routine Maintenance

The Arm must be inspected and maintained at least once a year.

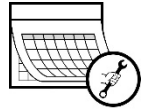

✓	Routine Maintenance Check List	Section
Counterbalance	With the device mounted, move the arm through its entire vertical range of motion. The load should maintain its position at every point in the travel of arm. If necessary, the counterbalance mechanism may be adjusted.	8.1
Tilt	Grasp the mounted device and tilt it forward and back, through its entire range of motion. There should be enough tension or resistance in the tilt mechanism to prevent the device from tilting forward unexpectedly when in use. If necessary, the tilt tension may be adjusted.	8.2
Swivel	Grasp the mounted device and swivel it from side to side. The device should swivel with some tension or resistance, not loosely. If necessary, the swivel tension may be adjusted.	8.3
Pivot	Grasp the Arm and pivot it from side to side at the Center Pivot and Rear Pivot. The arm should pivot with some tension or resistance, not loosely. If necessary, the pivot tension may be adjusted.	8.4 8.5
Hardware	Inspect fasteners for looseness. Tighten as required for optimal operation and safety.	5.0 6.0 7.0

12.0 Cleaning the VHM-P Arm

The Arm may be cleaned with most mild, non-abrasive solutions commonly used in the hospital environment (e.g. diluted bleach, ammonia, or alcohol solutions).

The surface finish will be permanently damaged by strong chemicals and solvents such as acetone and trichloroethylene.

Steel wool or other abrasive material should never be used.

Damage caused by the use of unapproved substances or processes will not be warranted. We recommend testing any cleaning solution on a small area of the arm that is not visible, to verify compatibility.

Never submerge or allow liquids to enter the arm. Wipe any cleaning agents off of the arm immediately using a water-dampened cloth. Dry the arm thoroughly after cleaning.

CAUTION: GCX makes no claims regarding the efficacy of the listed chemicals or processes as a means for controlling infection. Consult your hospital's infection control officer or epidemiologist. To clean or sterilize mounted instruments or accessory equipment, refer to the specific instructions delivered with those products.

13.0 Troubleshooting the VHM-P Arm

Symptom	Possible Cause	Remedy
Mounted device does not appear level or parallel to the floor.	Channel not plumb. Check with level.	Adjust Channel to plumb, or reinstall Channel.
	Weight of device not compatible with Load Rating of the Arm.	Mount device on arm with compatible Load Rating (section 3.0).
	Swivel hardware loose.	Adjust Swivel Tension Nut (section 8.3).
	Pivot hardware loose.	Adjust Pivot Tension (section 8.4, 8.5).
	Mounting surface (e.g., wall, side of anesthesia machine, etc.) not structurally sound (does not hold mounting hardware).	Mounting surface must be reinforced or Channel must be relocated.
	Channel loose at mounting surface.	Check for plumb and tighten, or relocate (reinstall) Channel.
	Suspension Front End fasteners are loose.	Tighten Suspension Front end fasteners (section 5.0).
Mounted device drifts up or down.	Arm not counterbalanced correctly for weight of the device.	Perform counterbalance adjustment (section 8.1).
	Weight of mounted device not compatible with Load Rating Range of Arm.	Use arm with compatible Load Rating Range (section 3.0).
Mounted device difficult to move up or down.	Arm not counterbalanced correctly for weight of mounted device.	Perform counterbalance adjustment (section 8.1).
Arm pivots too freely.	Pivot tension is too loose.	Adjust Pivot Tension (section 8.4, 8.5).
Arm is difficult to pivot.	Pivot tension is too tight.	
Device swivels too freely.	Swivel tension is too loose.	Adjust Swivel Tension (section 8.3).
Device is difficult to swivel.	Swivel tension is too tight.	
Device is difficult to tilt.	Tilt tension is too tight.	Adjust Tilt Tension (section 8.2).
Device will not maintain tilt position.	Tilt tension is too loose.	
Arm inadvertently slides down Channel.	Set Screws (4) in Slide are loose.	Reposition Arm, tighten set screws in slide, and secure adjustable stop (section 6.2 and 6.4).
	Adjustable Stop is loose or missing.	Install or secure adjustable stop (section 6.2).
Arm motion feels restricted or limited.	Improper cable routing is causing interference and/or cable binding.	Inspect cable routing and ensure proper anchorage, service loops, and path routing; Adjust as needed (Section 9).