

**Operation Guide**  
**VHM-P (Non-Locking) and VHM-PL (Locking) Variable Height Arm (Slide-Above-Arm Configuration)**  
**For Philips IntelliVue MP5/20/30/40/50, MX400/450/500/550/600/700/800**

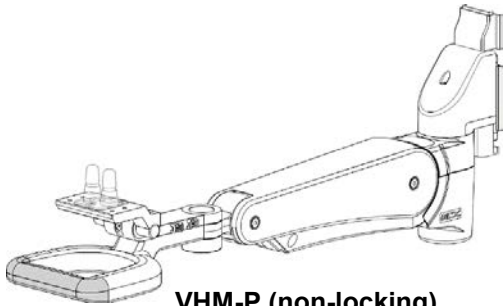

**VHM-P (non-locking)**  
(Table Mount supplied by Philips)

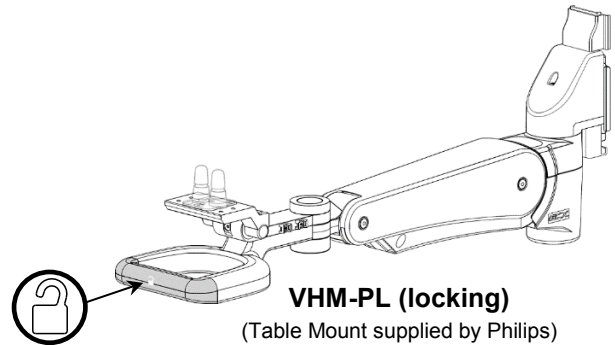

**VHM-PL (locking)**  
(Table Mount supplied by Philips)

**Safety Label Locations (VHM-P Series Arms)**

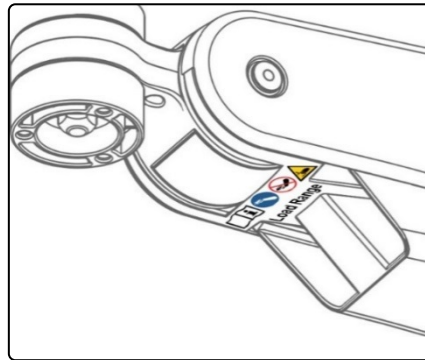
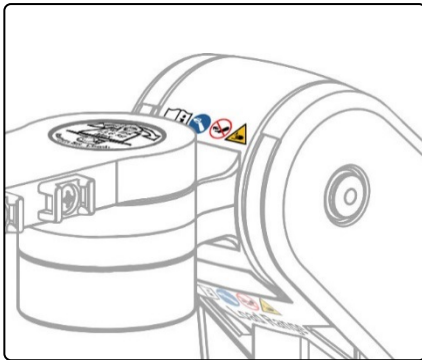

Refer to Installation Guide for additional information.



Remove the Device only when the Arm is at the highest position.



Do not remove device when arm is in a lowered position.



Potential pinch point that may cause personal injury.



Maximum weight for mounting plate with tilt function.

**Counter Balance Load Range:**  
**25 - 45 lbs / 11.3 - 20.4 kg**  
 or  
**15 - 30 lbs / 6.8 - 13.6 kg**

**Safety Label Locations (VHM-PL Series Arms)**

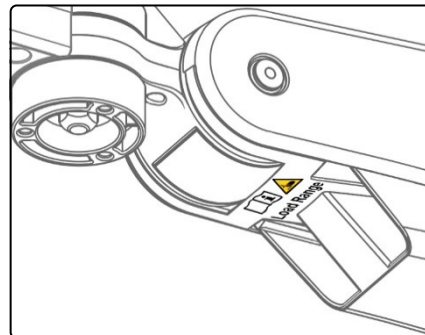
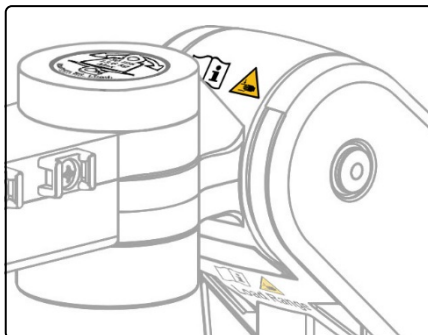

Refer to Installation Guide for additional information.



Potential pinch point that may cause personal injury.



Maximum weight for mounting plate with tilt function.

**Counter Balance Load Range:**  
**20 - 45 lbs / 9.1 - 20.4 kg**  
 or  
**11 - 30 lbs / 5.0 - 13.6 kg**

VHM-P (non-locking only)

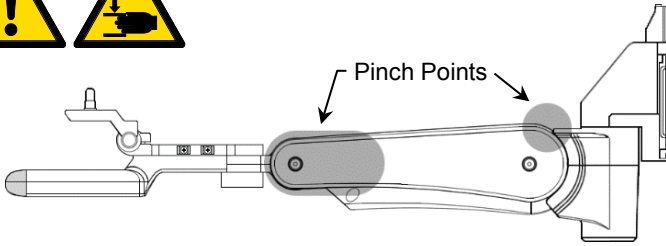
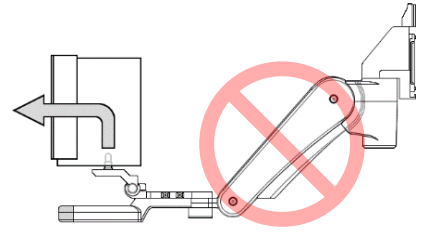
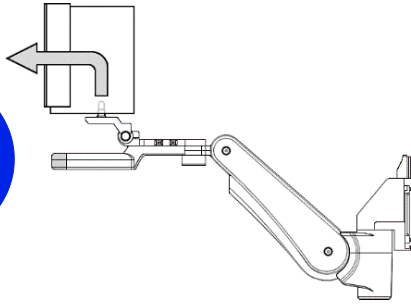

VHM-P (non-locking)

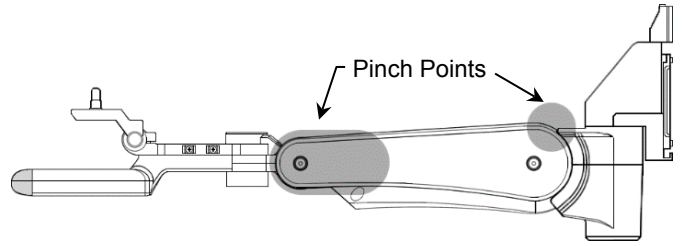

VHM-PL (locking)

VHM-P (non-locking)

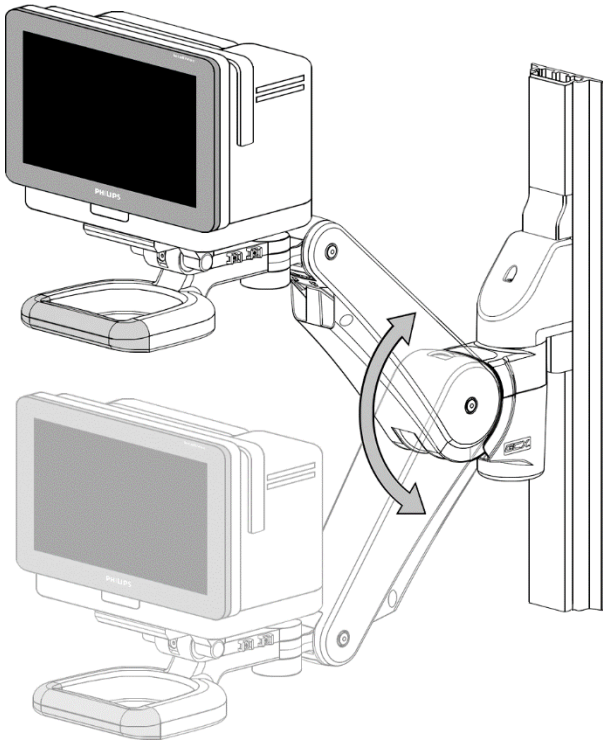

VHM-PL (locking)

