

**Operation Guide**

**VHM-P (Non-Locking) and VHM-PL (Locking) Variable Height Arm (Slide-Below-Arm Configuration)**

**For Philips IntelliVue MP5/20/30/40/50, MX400/450/500/550/600/700/800**

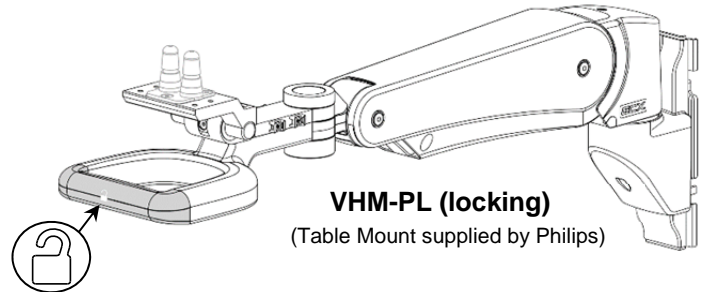
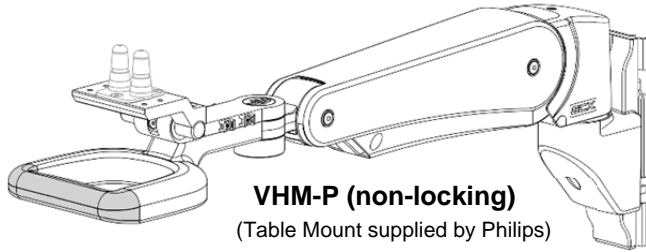

**Safety Label Locations (VHM-P Series Arms)**

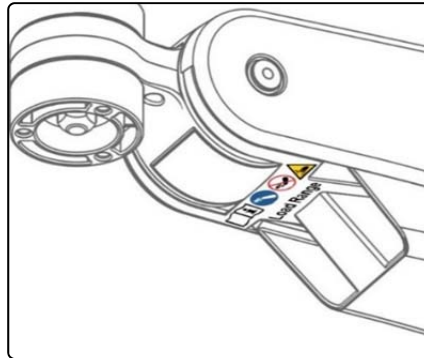
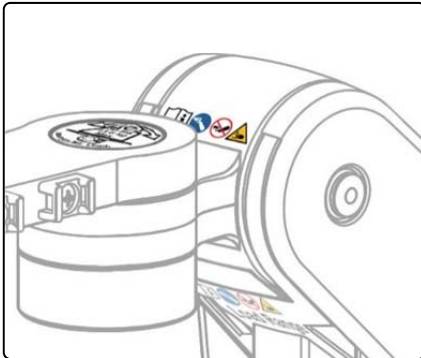

Refer to Installation Guide for additional information.



Remove the device only when the arm is at the highest position.



Do not remove the device when the arm is in a lowered position.



Potential pinch point that may cause personal injury.



Maximum weight for mounting plate with tilt function.

**Counter Balance Load Range:**  
25 - 45 lb / 11.3 - 20.4 kg  
or  
15 - 30 lb / 6.8 - 13.6 kg

**Safety Label Locations (VHM-PL Series Arms)**

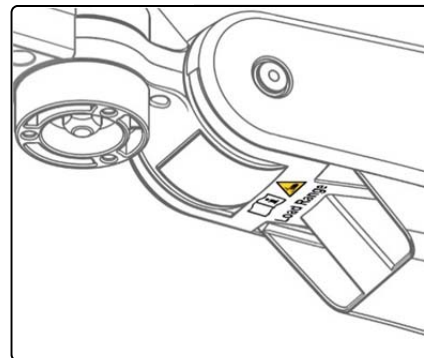
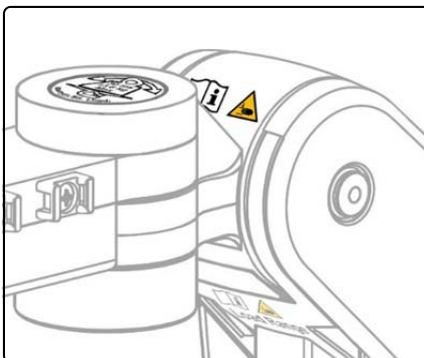

Refer to Installation Guide for additional information.



Potential pinch point that may cause personal injury.



Maximum weight for mounting plate with tilt function.

**Counter Balance Load Range:**  
20 - 45 lb / 9.1 - 20.4 kg  
or  
11 - 30 lb / 5.0 - 13.6 kg

VHM-P (non-locking only)

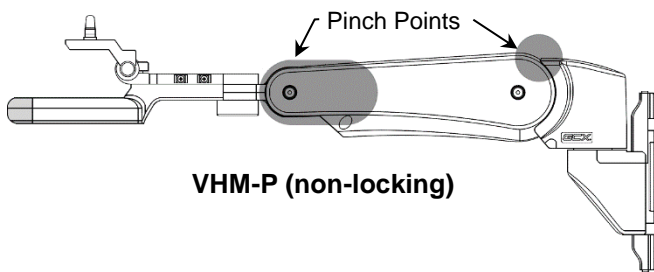
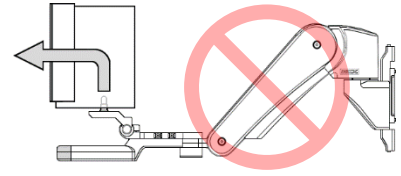
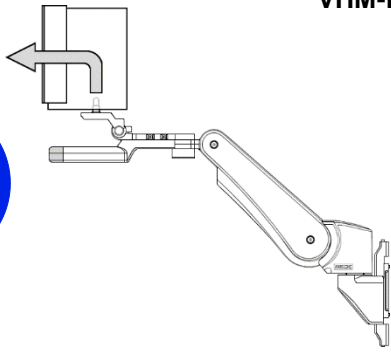

VHM-P (non-locking)

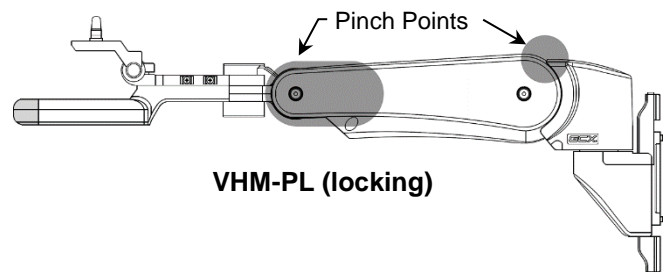

VHM-PL (locking)

VHM-P (non-locking)

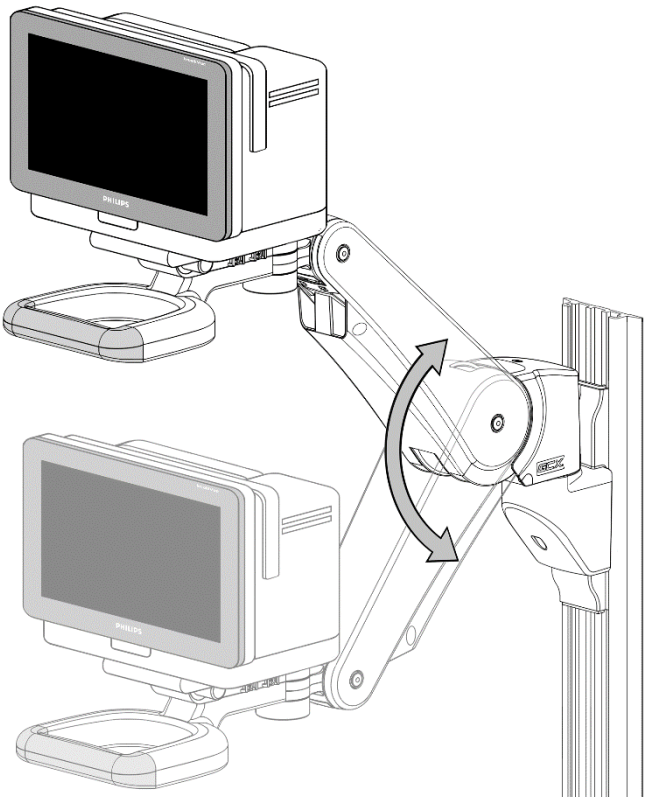

VHM-PL (locking)

