

### Installation Guide

## VHM-P (Non-Locking) and VHM-PL (Locking) Variable Height Arm with 8"/20.3cm or 14"/35.6cm Extension For Philips IntelliVue MP5/20/30/40/50, MX400/450/500/550/600/700/800

(Refer to qualified personnel)

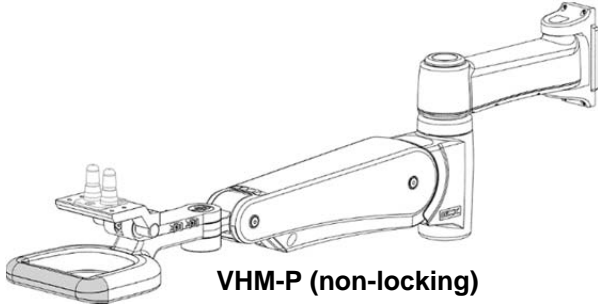

**VHM-P (non-locking)**

(Table Mount supplied by Philips)

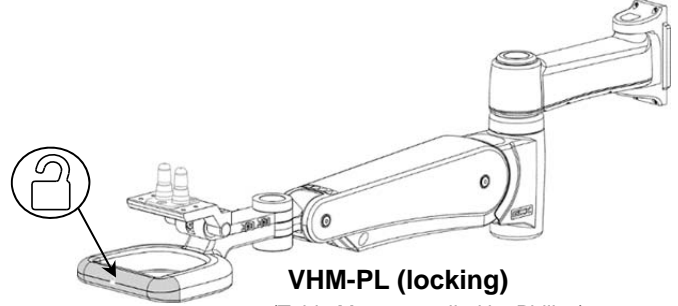

**VHM-PL (locking)**

(Table Mount supplied by Philips)

VHM-P (Non-Locking)				
Part Number	Extension	Arm Load Range	Max Tilt Load	Device Compatibility
PH-0077-48	8" / 20.3 cm	25-45 lb / 11.3-20.4 kg	30 lb / 13.6 kg	IntelliVue MX600/700/800
PH-0077-49	14" / 35.6 cm	25-45 lb / 11.3-20.4 kg	30 lb / 13.6 kg	IntelliVue MX600/700/800
PH-0079-48	8" / 20.3 cm	15-30 lb / 6.8-13.6 kg	30 lb / 13.6 kg	IntelliVue MP20/30/40/50, MX400/450/500/550
PH-0079-49	14" / 35.6 cm	15-30 lb / 6.8-13.6 kg	30 lb / 13.6 kg	IntelliVue MP20/30/40/50, MX400/450/500/550
VHM-PL (Locking)				
Part Number	Extension	Arm Load Range	Max Tilt Load	Device Compatibility
PH-0077-04	8" / 20.3 cm	20-45 lb / 9.1-20.4 kg	30 lb / 13.6 kg	IntelliVue MX600/700/800
PH-0077-05	14" / 35.6 cm	20-45 lb / 9.1-20.4 kg	30 lb / 13.6 kg	IntelliVue MX600/700/800
PH-0079-04	8" / 20.3 cm	11-30 lb / 5.0-13.6 kg	30 lb / 13.6 kg	IntelliVue MP5/20/30/40/50, MX400/450/500/550
PH-0079-07	14" / 35.6 cm	11-30 lb / 5.0-13.6 kg	30 lb / 13.6 kg	IntelliVue MP5/20/30/40/50, MX400/450/500/550

### Installation Time

Approximately 10-15 minutes

*The purpose of this manual is to describe general installation, operation, and adjustment procedures for VHM-P and VHM-PL Series Arms with Extension. This manual should be used in conjunction with any instrument-specific installation guides. Please read this manual and all instrument-specific installation material before installing or using this product.*

### Table of Contents

1.0	Parts Reference.....	2
2.0	Tools Required.....	2
3.0	Product Warning / Safety Labels.....	3
4.0	Installation, Operation, and Maintenance Warnings.....	4
5.0	Installing the Arm in Channel .....	5
6.0	Mounting the Device .....	6
7.0	Attaching the Down Post to the Arm.....	7
8.0	Adjusting the Arm .....	8
9.0	Cable Management.....	10
10.0	Routine Maintenance.....	15
11.0	Cleaning the Arm.....	15
12.0	Troubleshooting the VHM-P and VHM-PL.....	16

## 1.0 Parts Reference

The following parts and hardware are included and labeled accordingly:

Item #	Description	Quantity
1	VHM-P (a) or VHM-PL (b) Channel Mount Arm with Extension	1
2	Cable Cover	1
3	Center Pivot Cover	1
4	Fixed Mount Spacer (For Philips Device w/o Table Mount Interface)	1
5	9" (22.9cm) Down Post with hardware ( <b>INCLUDED WITH PH-0077-XX ONLY</b> )	1
6	Cable Tie	8
7	16" (40.6 cm) Channel Cover	1
8	Adjustable Stop	1
9	30.5" (77.5 cm) Cable Sleeve	2
10	1/2" (13mm) x 3/4" (19mm) Wrench	1
11	1/8" Hex Wrench ( <i>not shown</i> )	1
12	5/32" Hex Wrench ( <i>not shown</i> )	1
13	M6 x 12mm Flat Head Machine Screw (FHMS) ( <i>not shown</i> )	3
14	M6 x 14mm Pan Head Machine Screw (PHMS) ( <i>not shown</i> )	2

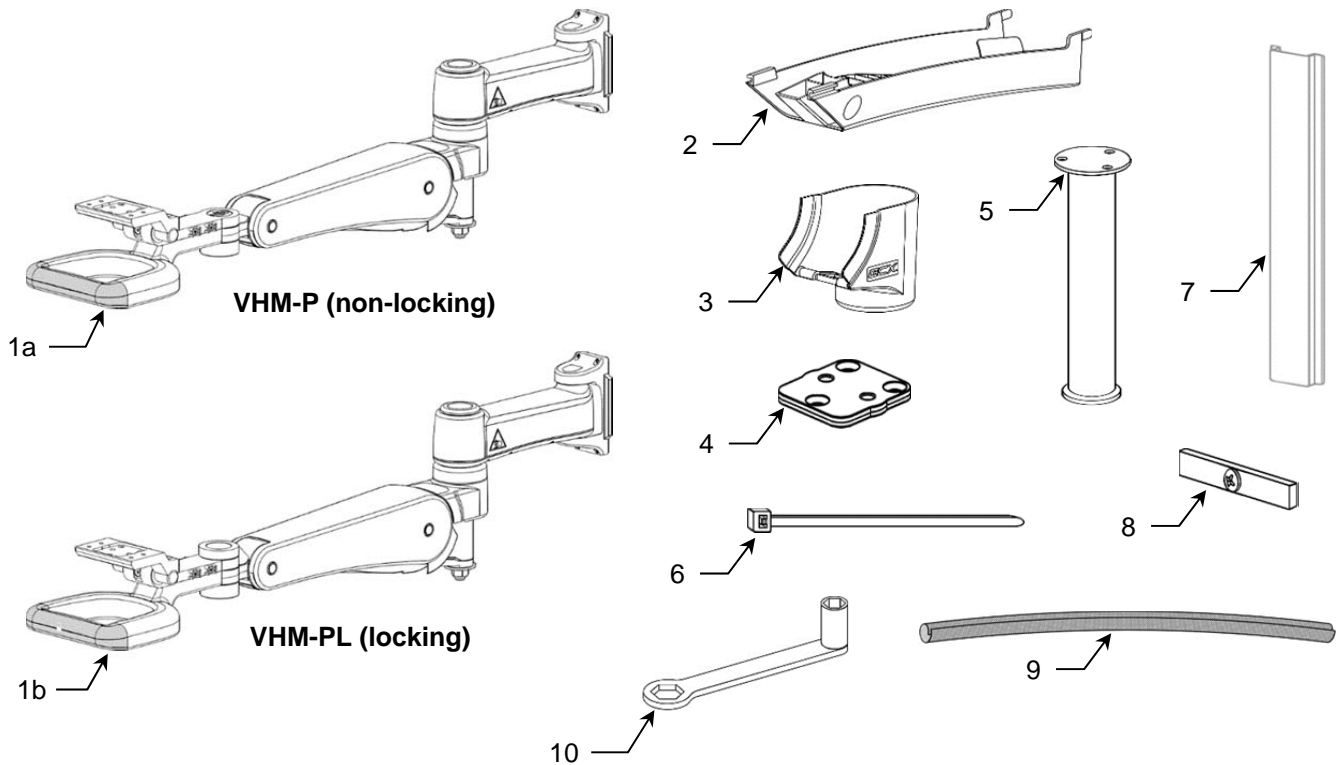

## 2.0 Tools Required

The tools listed below are required to install and adjust the arm.

### Provided

- 1/8" Hex Wrench
- 5/32" Hex Wrench
- 1/2" (13mm) / 3/4" (19mm) Wrench

### Not Provided

- #2 and #3 Phillips Screwdrivers
- Scissors, utility knife or similar cutting tool
- Wire Cutters (for cable ties)

### 3.0 Product Warning / Safety Labels

#### Safety Label Locations (VHM-P Series Arms)

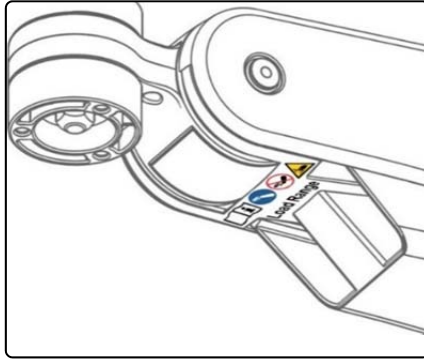
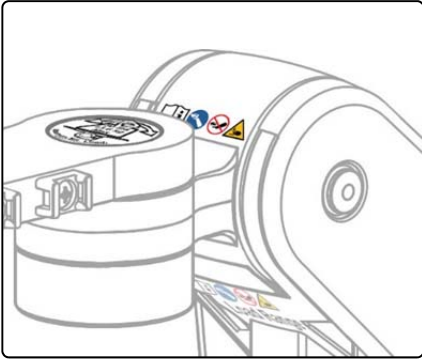

Refer to Installation Guide for additional information.



Remove the device only when the arm is at the highest position.



Do not remove the device when the arm is in a lowered position.



Potential pinch point that may cause personal injury.



Maximum weight for mounting plate with tilt function.

**Counter Balance Load Range:**  
**25 - 45 lb / 11.3 - 20.4 kg**  
 or  
**15 - 30 lb / 6.8 - 13.6 kg**

#### Safety Label Locations (VHM-PL Series Arms)

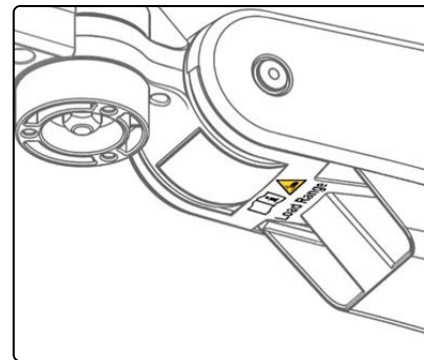
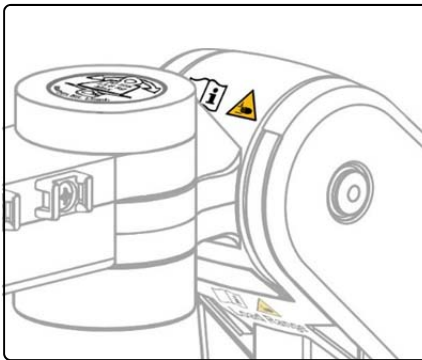

Refer to Installation Guide for additional information.



Potential pinch point that may cause personal injury.



Maximum weight for mounting plate with tilt function.

**Counter Balance Load Range:**  
**20 - 45 lb / 9.1 - 20.4 kg**  
 or  
**11 - 30 lb / 5.0 - 13.6 kg**

## 4.0 Installation, Operation, and Maintenance Warnings

This section contains warnings regarding the installation, operation, and maintenance of the arm. This section must be read in its entirety before installing, operating, and maintaining the arm. Failure to follow these warnings may result in damage to equipment or injury to personnel.



### Warnings

- Do not position the arm or mounted device above a patient. Note that the arm has a wide range of motion both up/down and side to side. Please consider carefully the device being mounted and the proximity of the mounting assembly to other equipment, hospital personnel, and the patient. GCX recommends that the hospital's risk management personnel verify that the application is appropriate prior to installation and use of this arm.
- Before the arm is channel mounted, verify that the channel has been installed and approved in accordance with the channel installation guide. Documents are available on our website: [www.gcx.com](http://www.gcx.com)
- Ensure that the total weight of the devices being mounted does not exceed the load rating of the arm. Check the bottom surface of the arm for the load range label. Refer to Section 3.0.
- Do not use power tools to make any arm adjustments.
- The mounted device or arm may move suddenly due to normal wear or improper adjustment of the tilt, swivel, and pivot functions (see Sections 8.2, 8.3, 8.4 and 8.5), improper counterbalance (Section 8.1) or ultimately, gas spring end of life. The gas spring has a limited life span and will lose some strength over a long period of time. **The arm must be inspected and maintained at least once a year.** This inspection must include the steps outlined in Section 10.0
- Failure to periodically inspect and adjust the arm as instructed may result in damage to equipment or injury. If you are unable to adjust the arm or require service, contact GCX technical support at 800.228.2555 or + 1 707.773.1100.
- Note that the VHM-P and VHM-PL arm have a wide range of motion both up/down and side to side. Please consider potential pinch points that may cause personal injury.

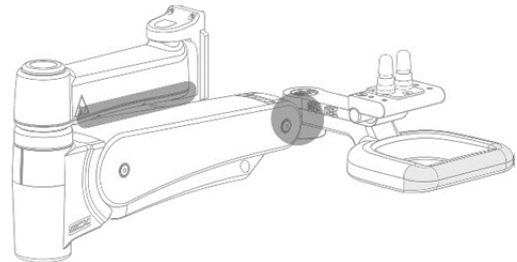
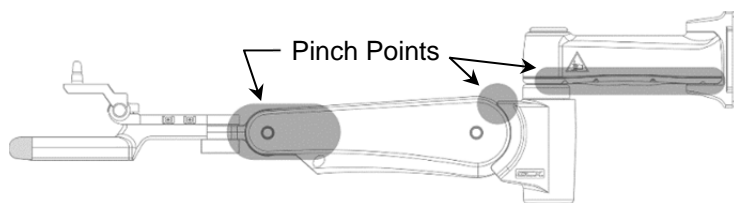

### VHM-P

- Remove the device only when the arm is at the highest position. Due to the counter balance function, the arm will naturally rise to the highest position when weight is removed. This can happen suddenly if the weight is removed at any height other than the highest point.

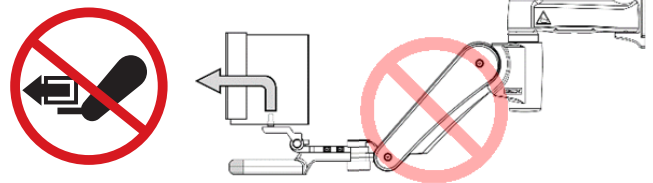
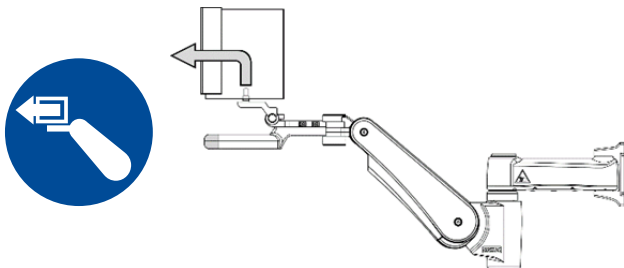

### VHM-P and PL

- Due to risk of personal injury or damage to the arm, the arm housing must never be disassembled by non-GCX personnel. Failure to comply will void the warranty.

## 5.0 Installing the Arm in Channel



Before mounting the arm, verify that the channel has been installed and approved in accordance with the channel installation guide included with the channel.

5.1 Insert adjustable stop into top of channel and slide to desired mounting position.

5.2 Using a #3 Phillips screwdriver, tighten the center screw to secure position.

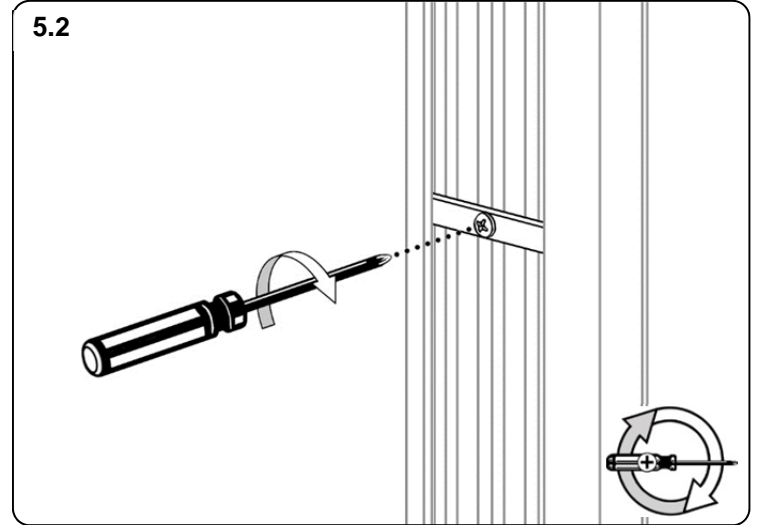
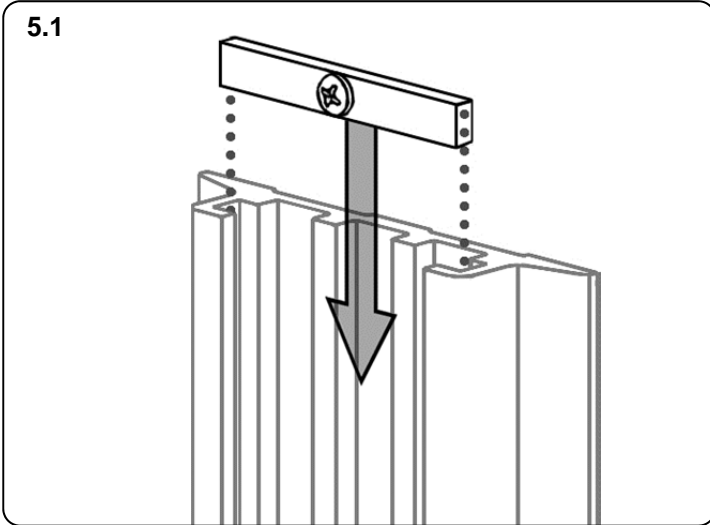

5.3 While supporting the arm, guide the slide into the top of the channel and position it against the adjustable stop.

5.4 Using a 1/8" hex wrench, tighten the (2) upper and the (2) lower set screws in the slide to secure the position of the arm.

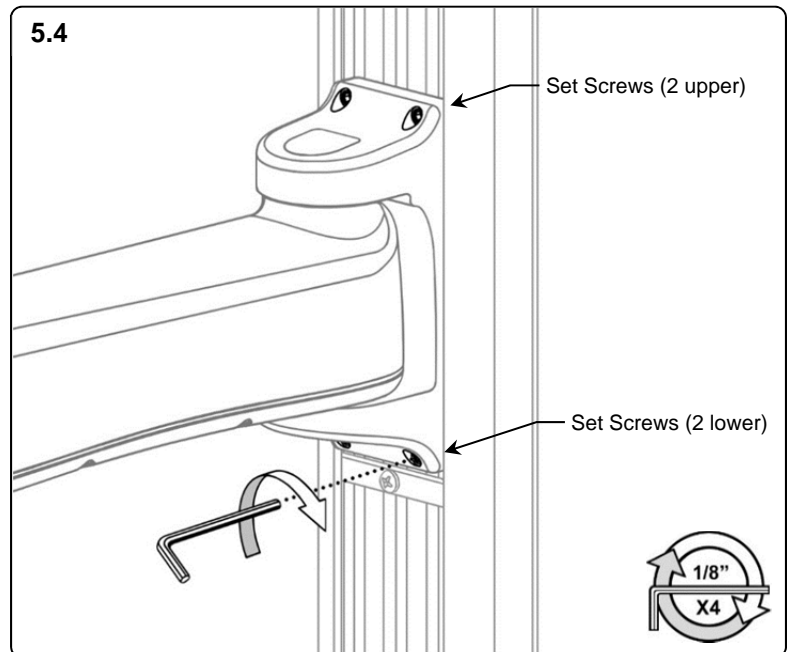
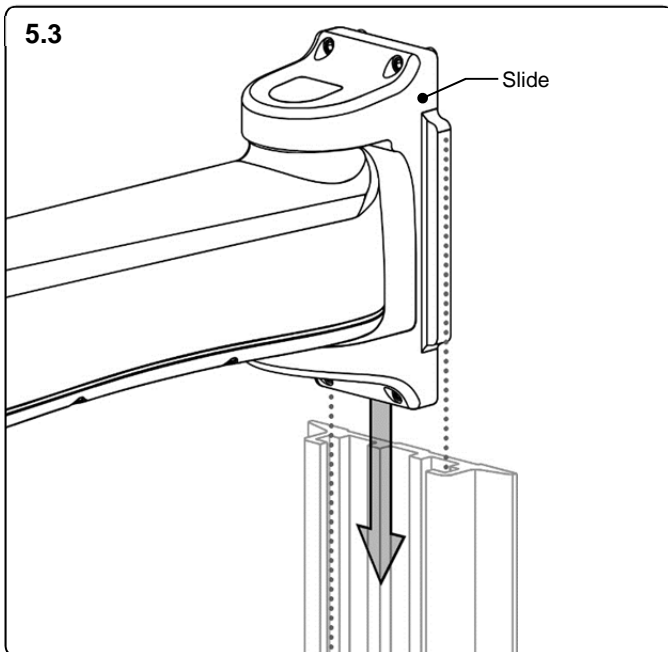

## 6.0 Mounting the Device



**Installation Note for MX600/700/800 and MP5/20/30 Monitors:** If equipped with either mounting interface shown in the pictures to the right, then mount in accordance with **Step 6.2 Non Table Mount** as shown below.

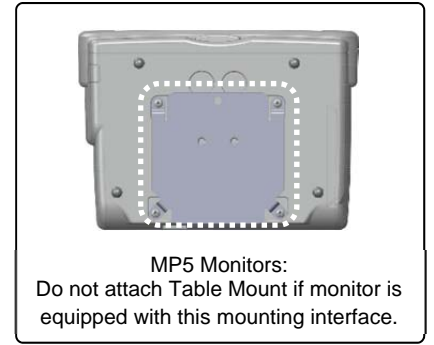
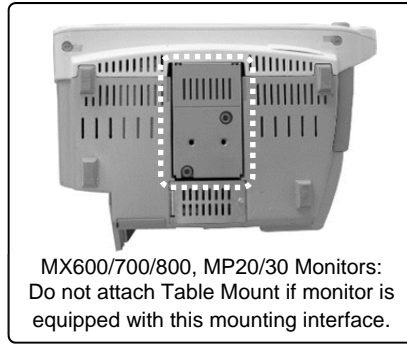

### 6.1 Table Mount

Fasten the Philips supplied Table Mount to the mounting plate as shown. Alternately tighten screws until Table Mount is secure. Mount the monitor in accordance with the Philips Table Mount instruction sheet. **Ensure the monitor mounting locking mechanism is properly engaged at all times.**

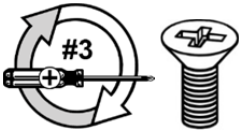
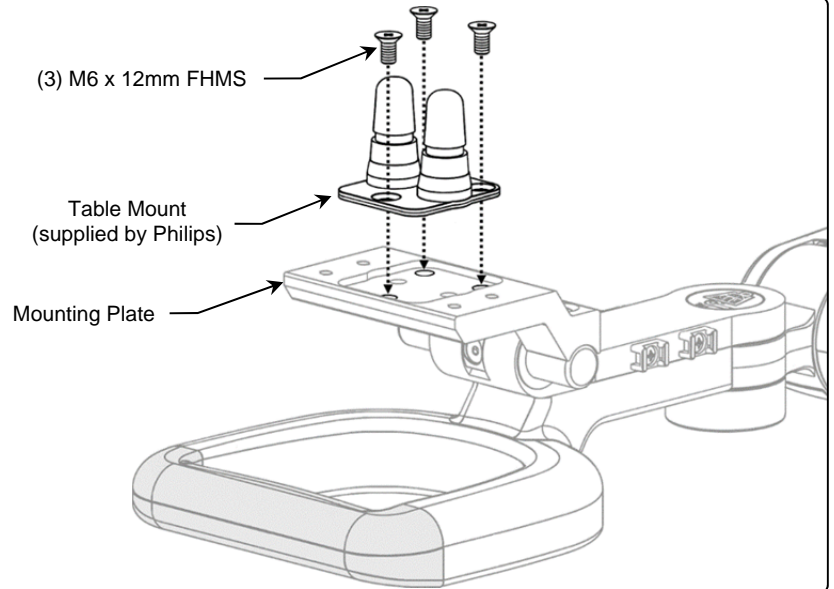

### 6.2 Non Table Mount

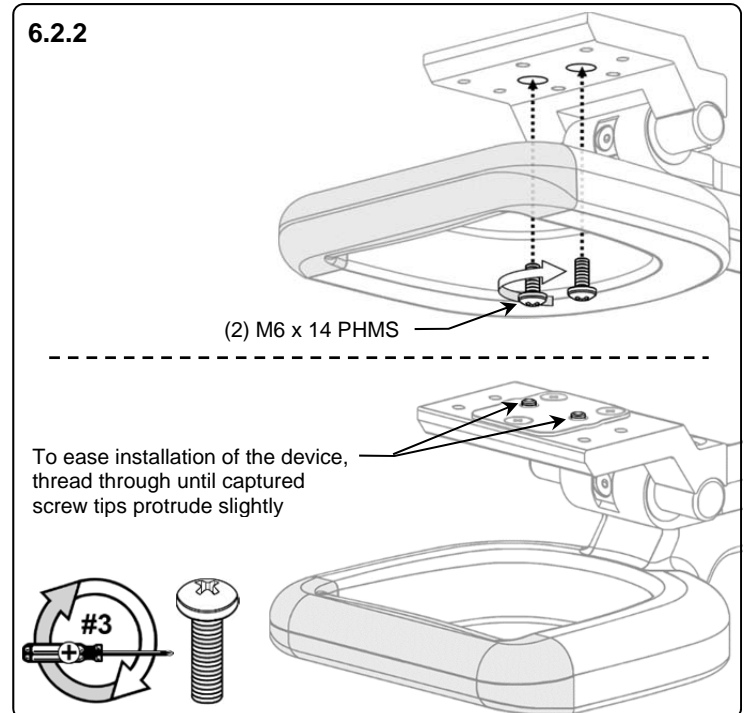
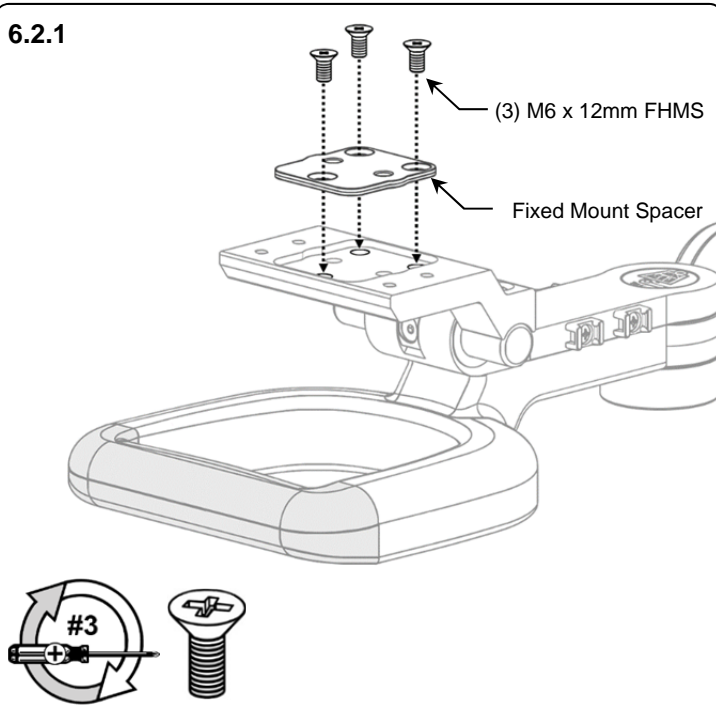

### 6.2.3

Visually align the protruding screw tips with the (2) threaded holes in the mounting interface located on the bottom of the monitor. Place the monitor on the mounting plate so that the screw tips engage the (2) threaded holes. Secure the monitor in place by tightening the (2) screws. An additional person may be needed to help support the monitor during this process.

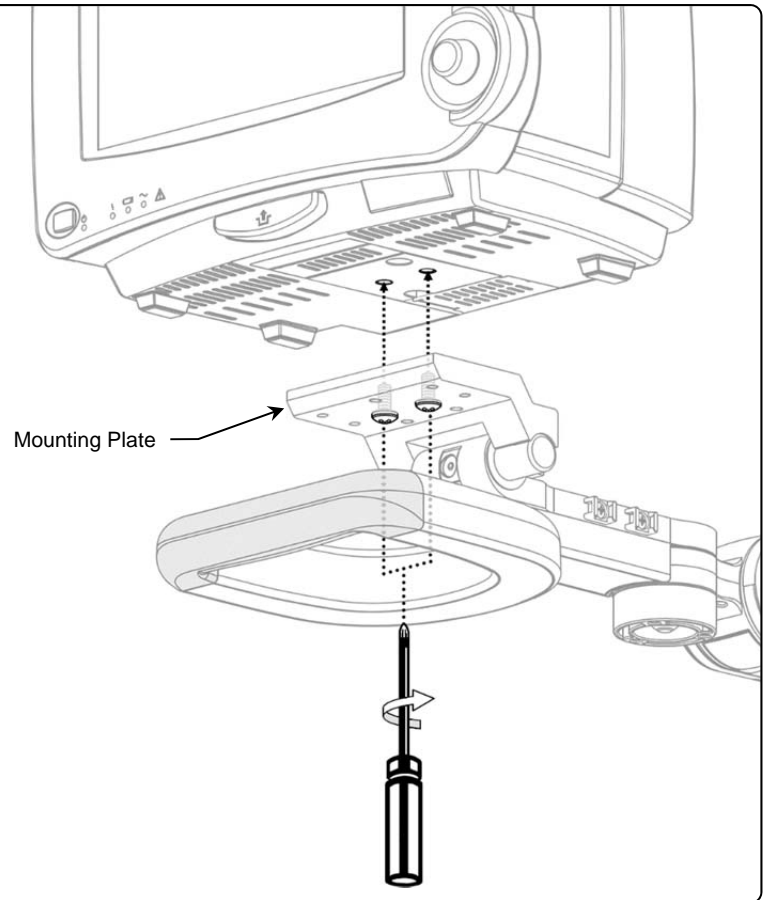

## 7.0 Attaching the Down Post to the Arm (INCLUDED WITH PH-0077-XX ONLY)

**Installation Note:** The down post is used for mounting the Flexible Module Server (FMS). Skip this procedure if your monitoring system does not require a down post or FMS. Refer to Section 8.3 prior to installing the down post.

- 1) Align the three (3) mounting holes in the lower post disk with the three (3) threaded holes in the swivel cup.
- 2) Using a 5/32" hex wrench, fasten post to swivel cup with three (3) #10-32 x 3/8" SHCS.

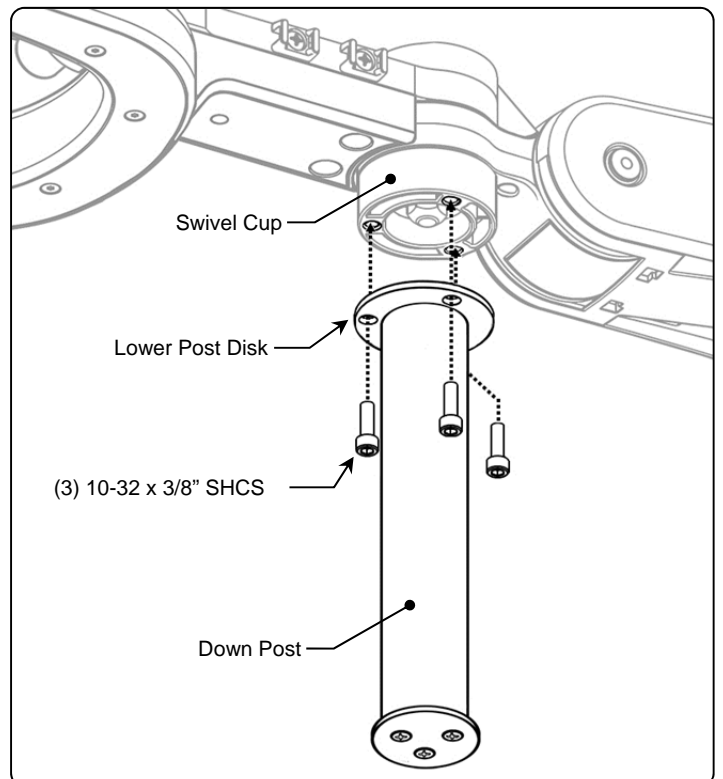

## 8.0 Adjusting the Arm

**Installation Note:** Adjustments are factory pre-set. However, adjustments to counterbalance, tilt tension, swivel tension and pivot tensions may all be required to achieve optimal arm performance. Detailed instructions for making adjustments follow in the section below. When properly adjusted the mounted device will move easily throughout the arms full range of motion. Refer to the Routine Maintenance Check List in Section 10 for a quick guide to these functional checks.



**Caution:** The counterbalance procedure is performed with the device(s) and accessories installed on the arm. Use caution as it may be necessary to support the weight of the arm/mounted device(s). This process may require an additional person. Use caution while performing this procedure.

### 8.1 Adjusting Counterbalance

#### Installation Note: VHM-PL (locking)

The VHM-PL arm is shipped in its upmost position (top of height adjustment range) – assure it is in this position before proceeding. The arm must be unlocked to perform the counterbalance adjustment. This is done by pulling the handle grip and inserting a 1/8" hex wrench into the handle grip holes as shown. When grip is released the hex wrench will stay in position to hold the handle grip in the un-lock position (the arm will freely move up and down). **Remove hex key after completing counterbalance adjustment.**

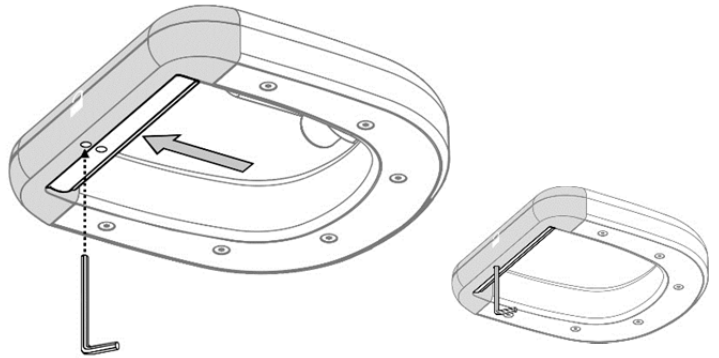

Move the arm to a level horizontal position and use a 5/32" hex wrench to increase (+) or decrease (-) the counterbalance setting.

**VHM-P:** Counterbalance is correctly set when the arm can be moved up or down with minimal force and does not float up or down after releasing the arm.

**VHM-PL:** Counterbalance is correctly set when the arm can be moved up or down with minimal force. A small amount of residual float up or down is okay and may be set per user preference. Arms with minimum payloads may encounter up to 4 lb (1.8 kg) of upward float even with the counter balance setting adjusted to the minimum; this is a normal condition.

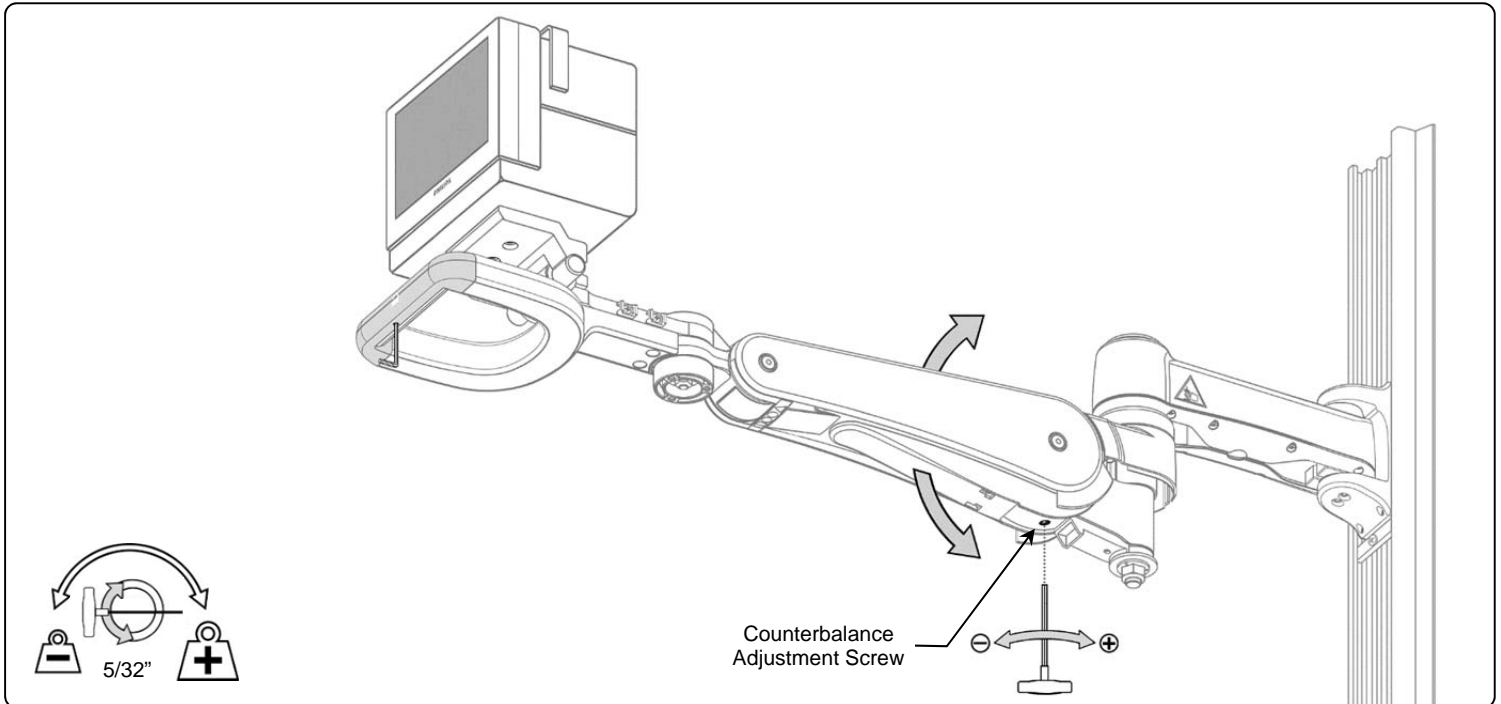



## 8.2 Tilt Tension Adjustment

**Note:** Tension is factory pre-set to accommodate many installations and therefore may not need adjustment.

Adjustment is performed with the device removed.

1. Using a 5/32 hex wrench, tighten (+) or loosen (-) both tilt tension adjustment screws until desired tilt tension is achieved. Adjustment range is approximately 1/2 turn total.
2. Replace the device and check tilt tension after adjustment is made and repeat as necessary.

**Caution:** Do not remove the adjustment screws.

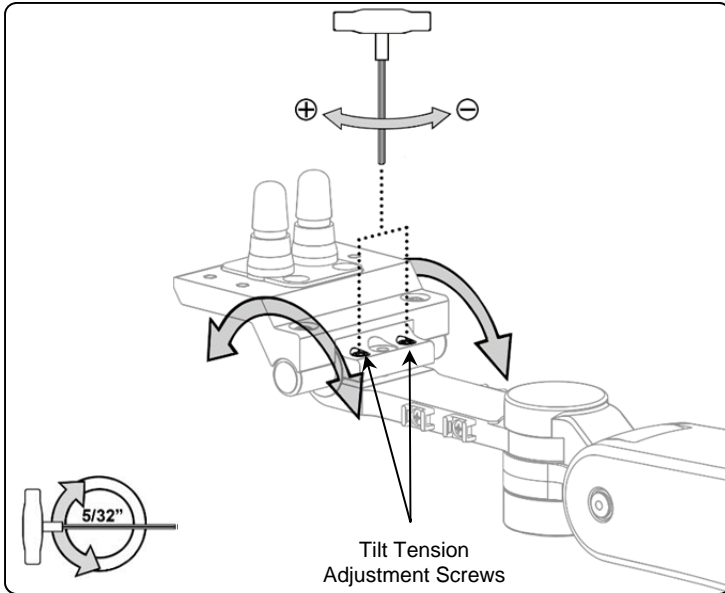

## 8.4 Center Pivot Tension Adjustment

**Note:** Tension is factory pre-set to accommodate many installations and therefore may not need adjustment.

To adjust the center pivot tension:

1. Tighten (+) or loosen (-) the pivot tension nut with a 3/4" (19 mm) wrench until desired tension is achieved.

**Caution:** Do not remove the pivot tension nut.

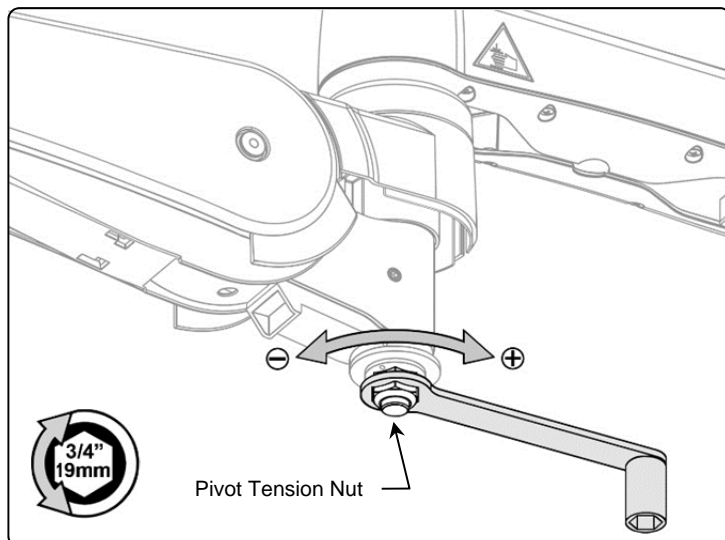

## 8.3 Swivel Tension Adjustment

**Note:** Tension is factory pre-set to accommodate many installations and therefore may not need adjustment.

To adjust the front swivel tension:

1. Tighten (+) or loosen (-) the swivel tension nut with a 1/2" (13 mm) wrench until desired tension is achieved. Total adjustment is approximately 1/4 to 1/2 turn.

**Caution:** Do not remove the swivel tension nut.

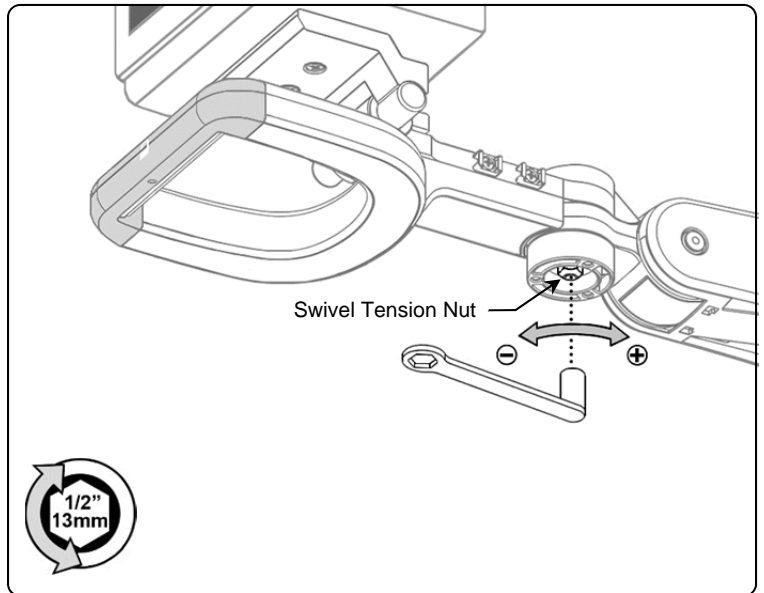

## 8.5 Rear Pivot Tension Adjustment

**Note:** Tension is factory pre-set to accommodate many installations and therefore may not need adjustment.

To adjust the rear pivot tension:

1. Tighten (+) or loosen (-) the tension screw with a #2 Phillips screwdriver until desired tension is achieved.

**Caution:** Do not remove the pivot tension screw.

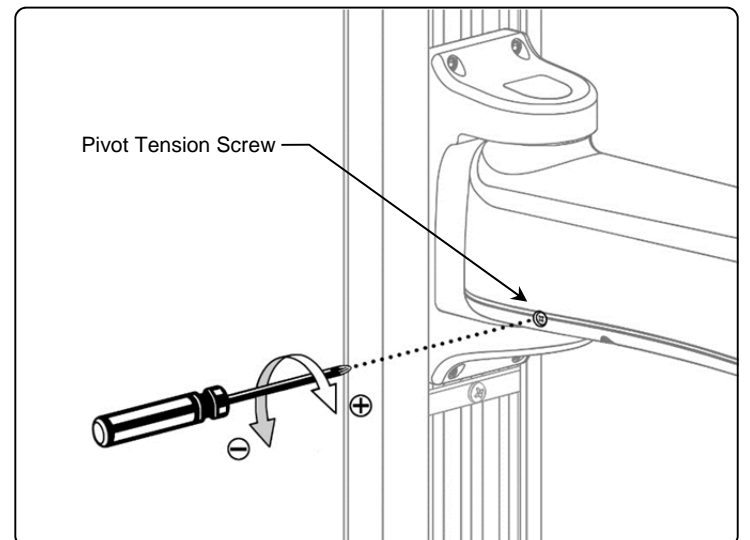

## 9.0 Cable Management

**Attention:** Follow these cable routing instructions to ensure unrestricted arm range of motion and to avoid possible damage to cables or the mounted device.

**Cable Management Overview:** Cables are routed from the device connections through the arm and into the channel. Cable service loops (cable slack) are established to prevent restricting range of motion when the arm or mounted device is repositioned. Cables are anchored at the front of the arm to preserve the necessary service loops. Cable sleeves are provided to assist in determining the correct service loops and to help protect and organize the cables. Cables routed through the arm are obscured from view and protected by plastic covers.

### 9.1 Preparing Service Loop 1

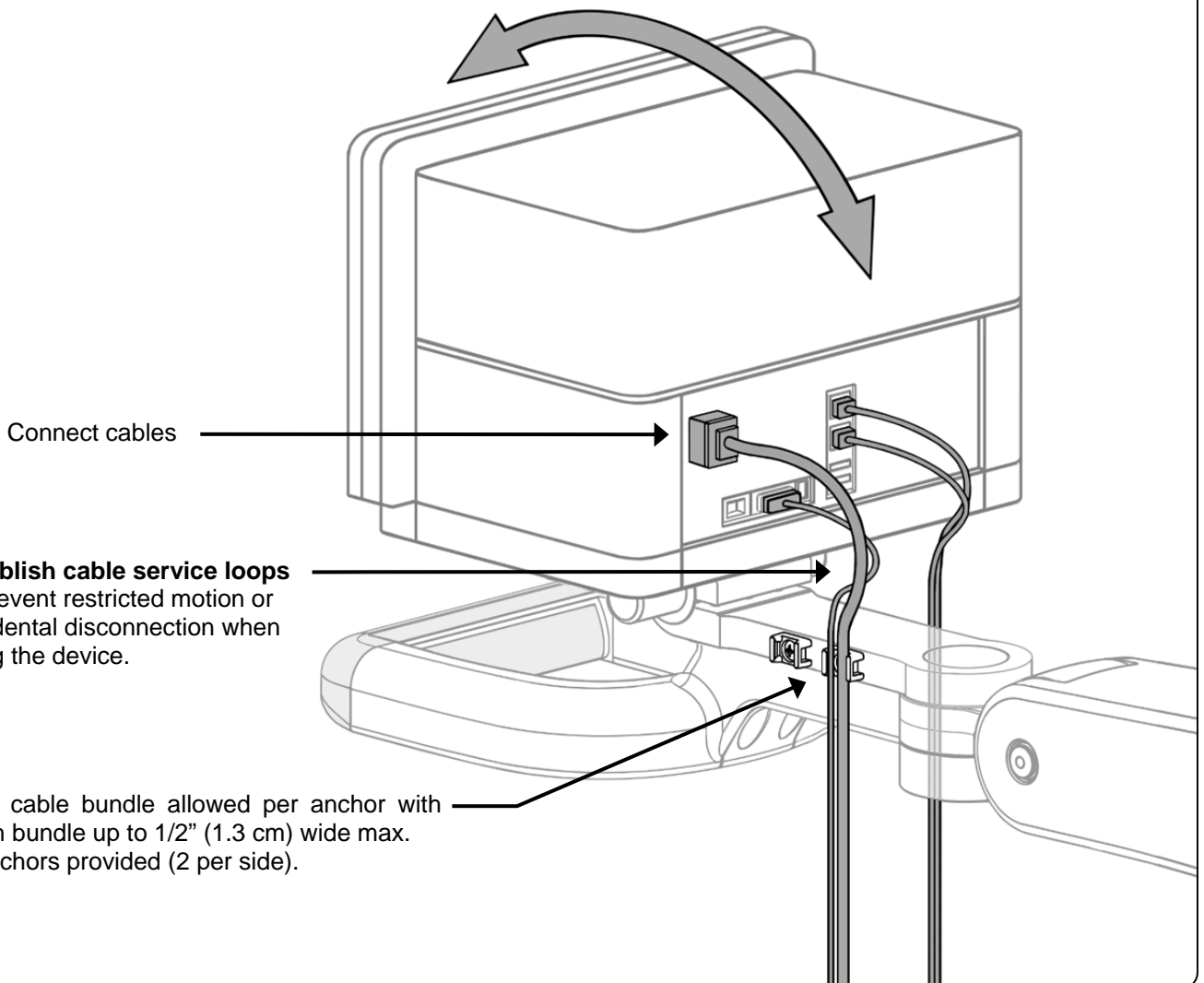

## 9.2 Setting Service Loop 1

Using the provided cable sleeves is recommended but optional.

Insert cables into the sleeves as shown below.

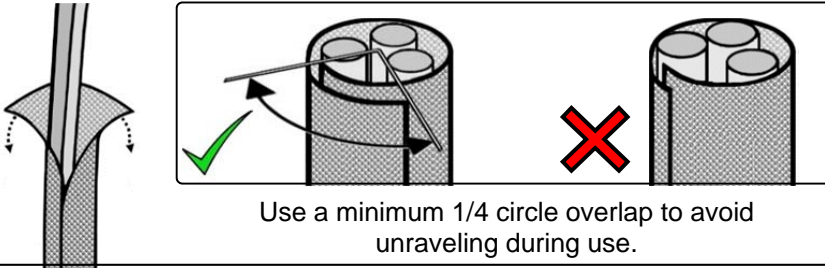

If using cable sleeves different than those provided with the arm then cut the sleeves to 30-1/2" (77.5 cm) in length and verify function within the arm prior to final product installation.

Position cable tie heads flush against the arm while tightening.

The provided cable ties have a release tab at the head.

Pliers may be used to help pull ties taut to secure cable bundles.

Clip excess length of cable ties as flush as possible to avoid creation of a sharp edge.

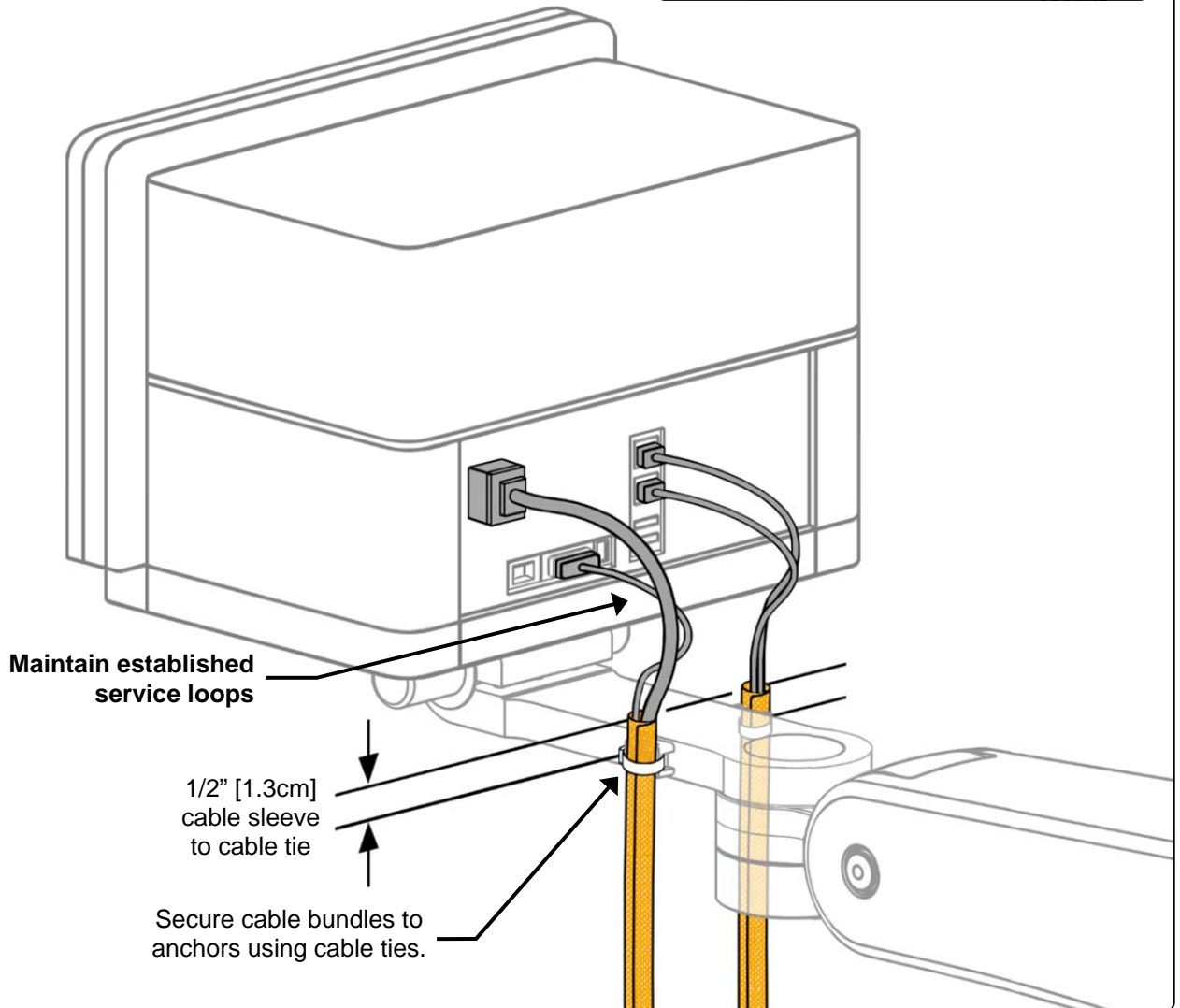
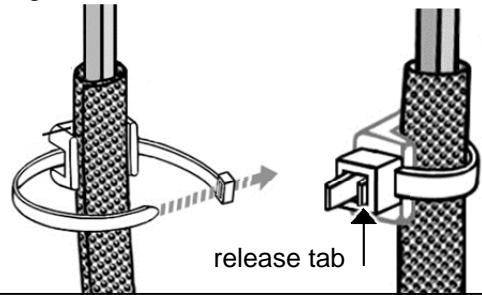

### 9.3 Preparing Service Loop 2

9.3.1 If not using cable sleeves then use this section to establish service loop 2. If using sleeves then skip to the next section.

**NOTE:** By using and positioning cable sleeves as recommended, the necessary length of service loop 2 will automatically be set by the length of the sleeves.

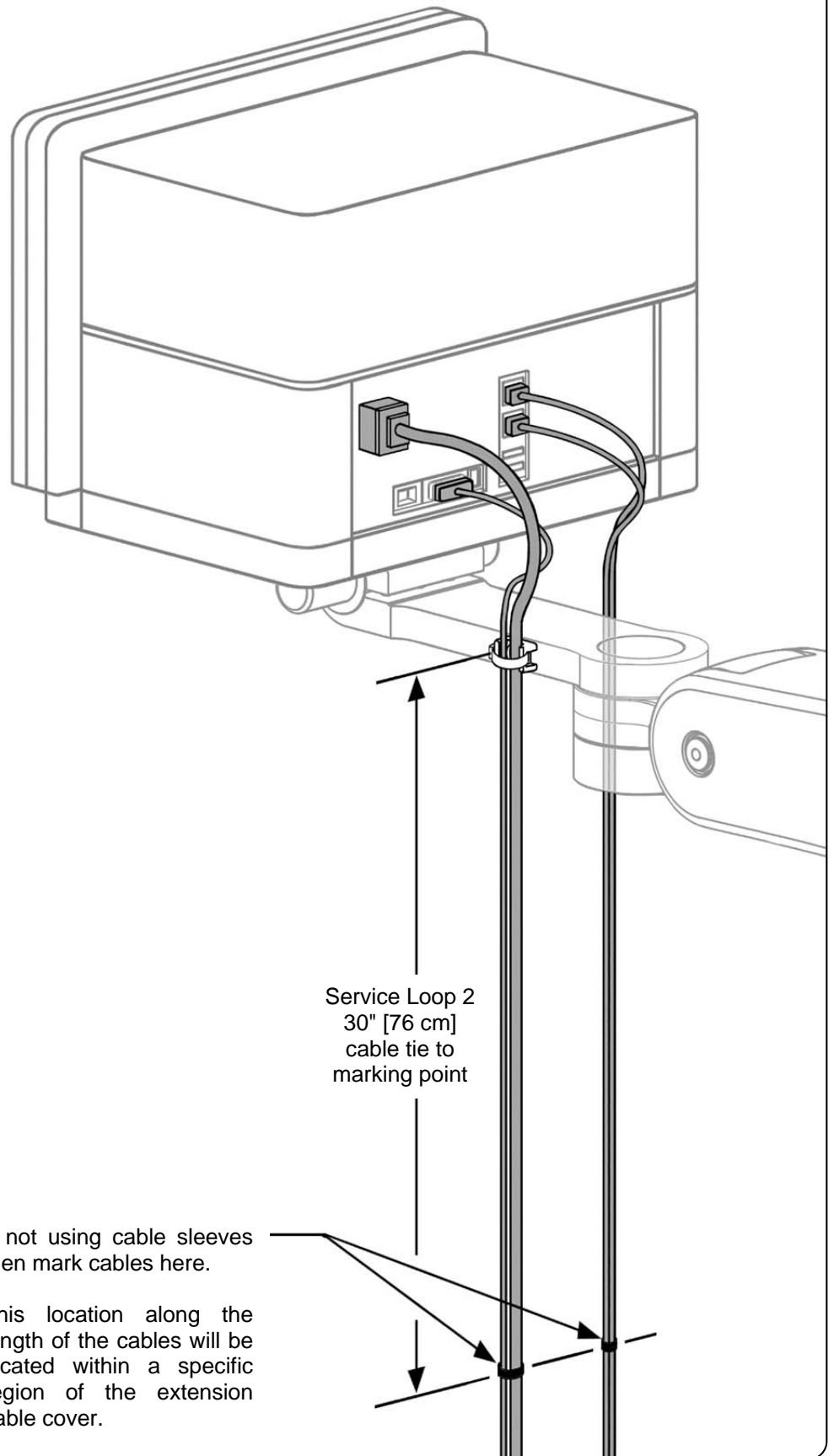

*Handle  
removed  
from view  
for clarity*

## 9.4 Installing the Cable Cover

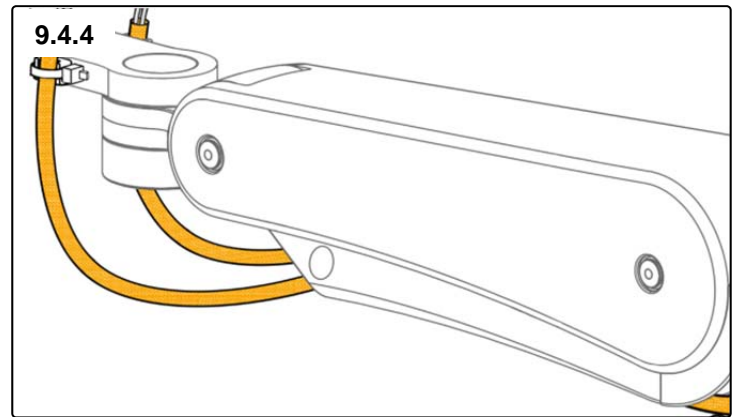
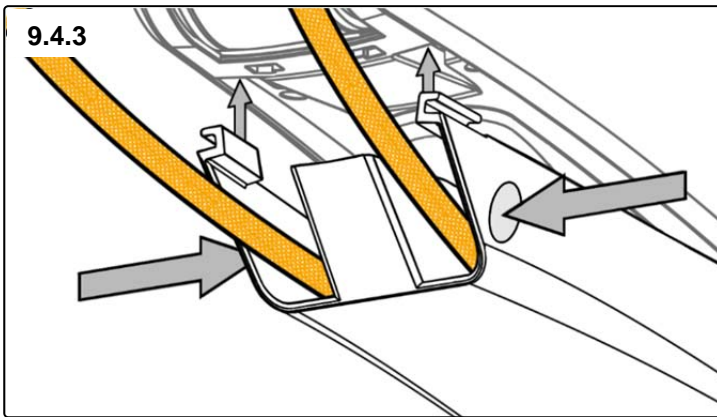
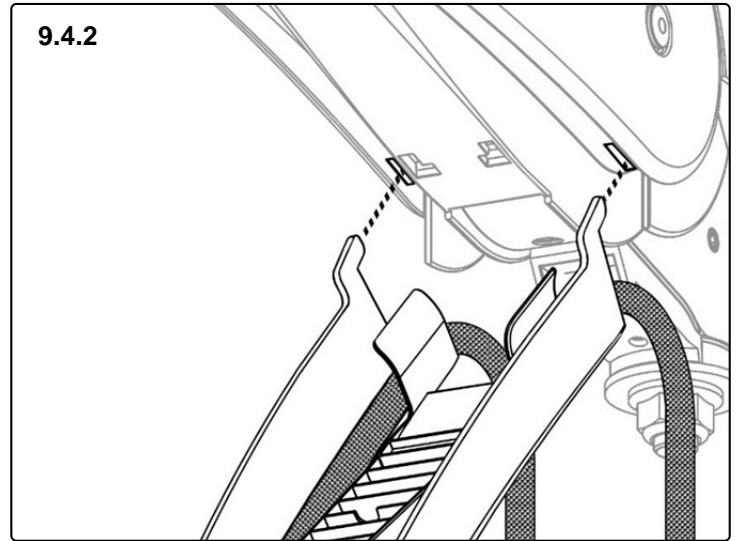
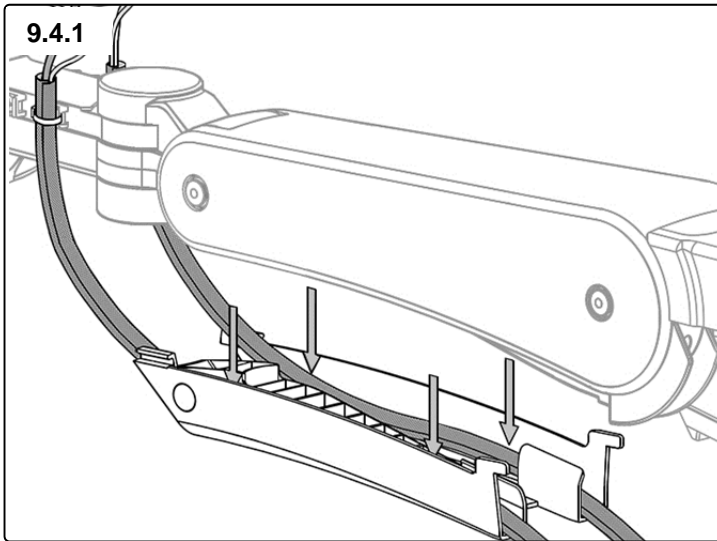

## 9.5 Setting Service Loop 2

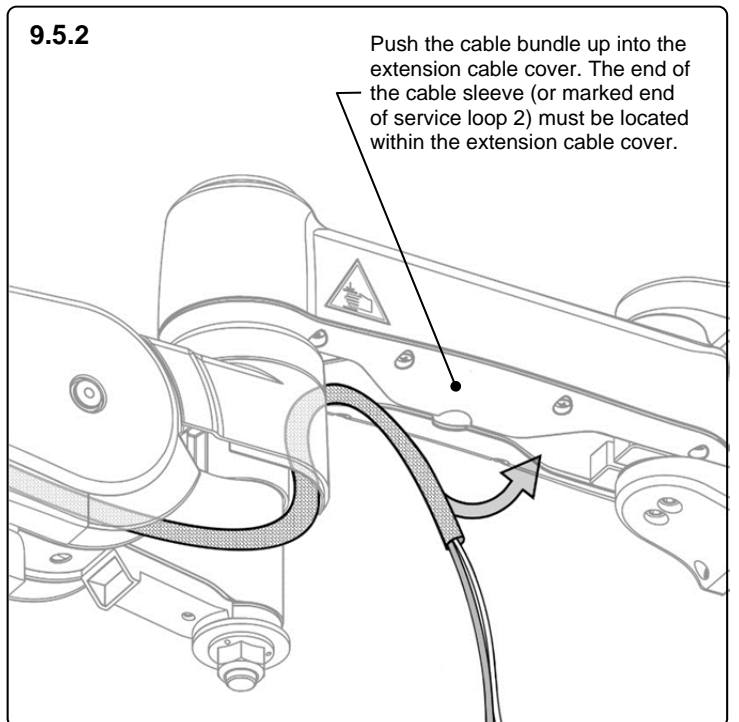
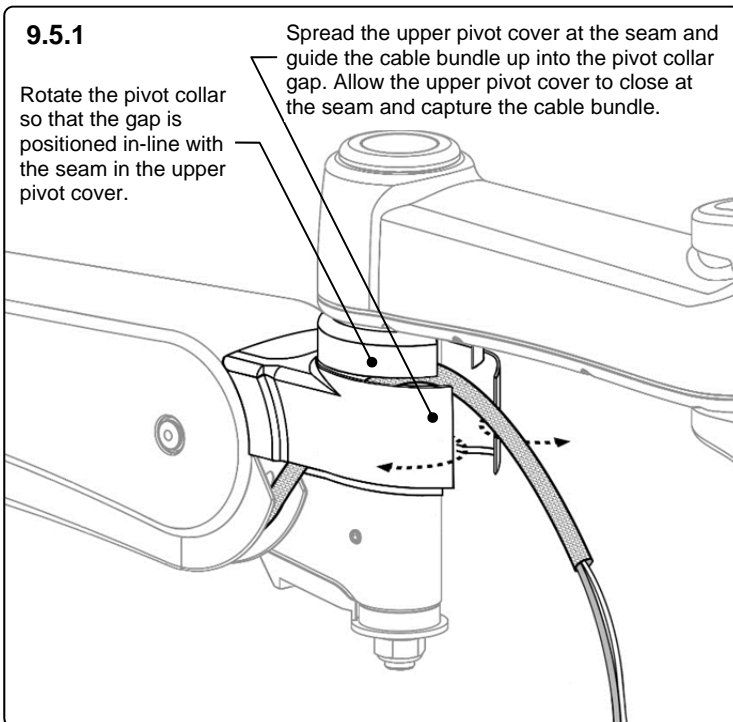

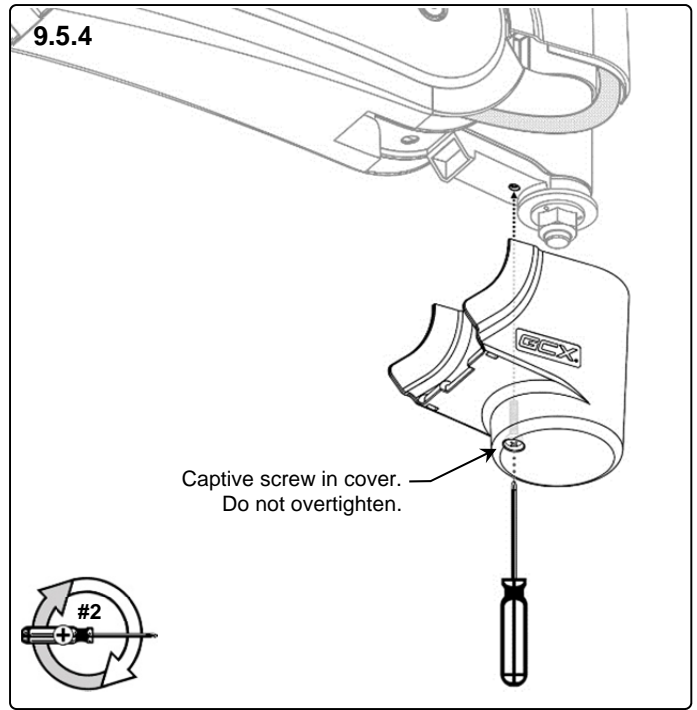
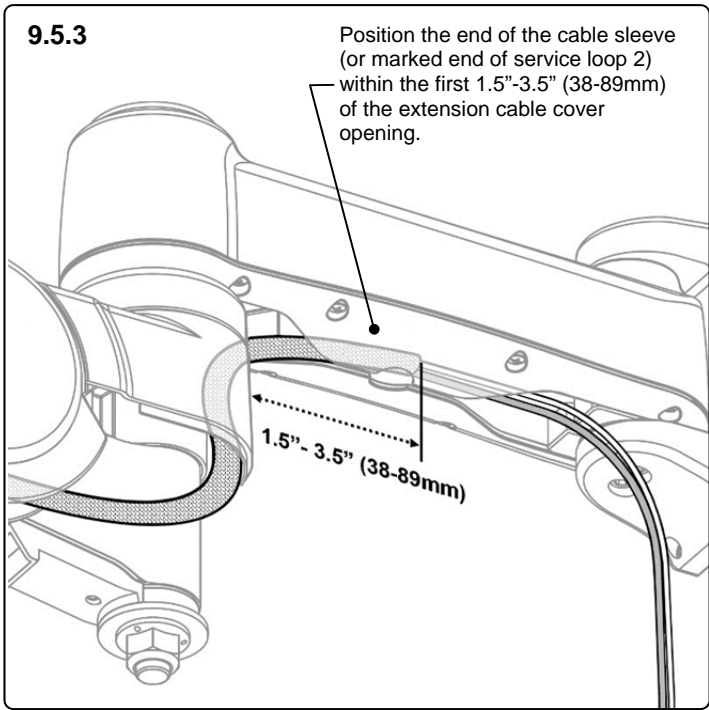

**9.6 Installing the Channel Cover**

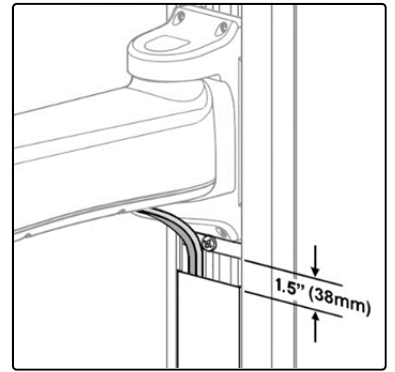
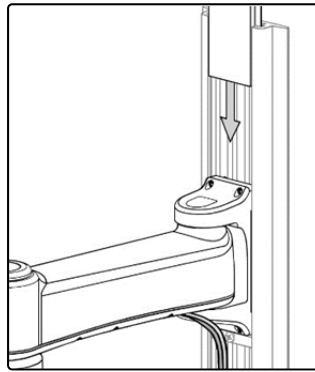
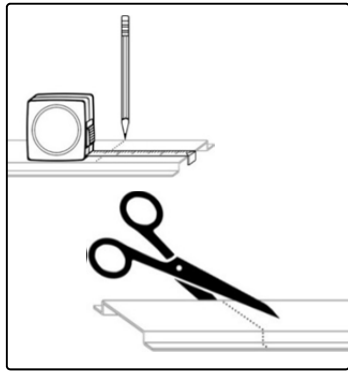
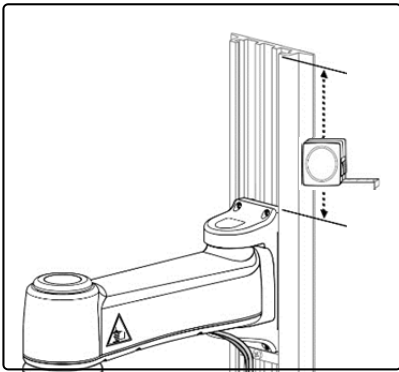

**9.7 Completed Cable Routing**

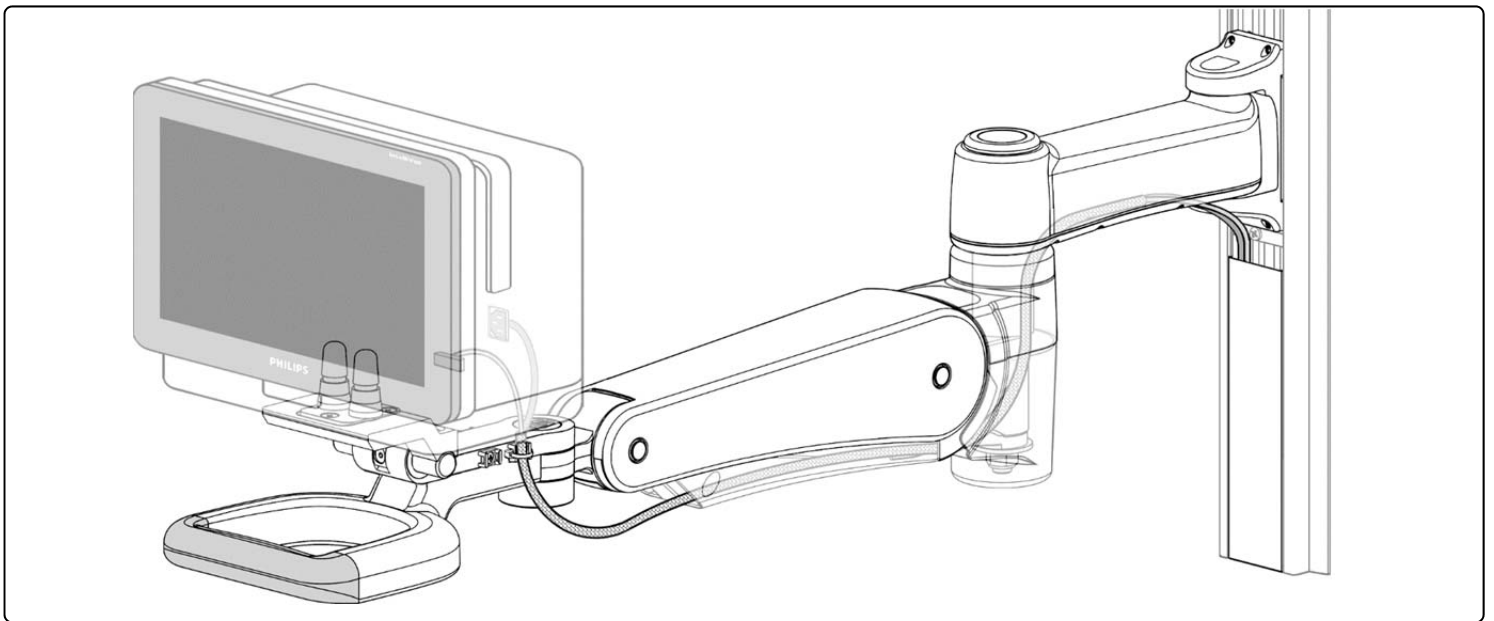

## 10.0 Routine Maintenance

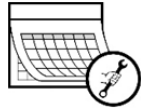

**The arm must be inspected and maintained at least once a year.**

✓	Routine Maintenance Check List	Section
<b>Counterbalance</b>	With the device mounted, move the arm through its entire vertical range of motion. The load should maintain its position at every point in the travel of the arm. If necessary, the counterbalance mechanism may be adjusted.	8.1
<b>Tilt</b>	Grasp the mounted device and tilt it forward and back, through its entire range of motion. There should be enough tension or resistance in the tilt mechanism to prevent the device from tilting forward unexpectedly when in use. If necessary, the tilt tension may be adjusted.	8.2
<b>Swivel</b>	Grasp the handle and swivel the arm from side to side at the front swivel joint. The device should swivel with some tension or resistance, not loosely. If necessary, the swivel tension may be adjusted.	8.3
<b>Pivot</b>	Grasp the arm and pivot it from side to side at the center pivot and rear pivot. The arm should pivot with some tension or resistance, not loosely. If necessary, the pivot tension may be adjusted.	8.4, 8.5
<b>Hardware</b>	Inspect fasteners for looseness. Tighten as required for optimal operation and safety.	5.2, 5.4, 6.1, 6.2, 7.0
<b>Cable Management</b>	Inspect cable management and ensure proper anchorage, service loops, and path routing; adjust as needed. Inspect cables and sleeves for damage and replace as needed.	9.0

## 11.0 Cleaning the VHM-P and VHM-PL Arm

The arm may be cleaned with most mild, non-abrasive solutions commonly used in the hospital environment (e.g. diluted bleach, ammonia, or alcohol solutions).

The surface finish will be permanently damaged by strong chemicals and solvents such as acetone and trichloroethylene.

Steel wool or other abrasive material should never be used.

Damage caused by the use of unapproved substances or processes will not be warranted. We recommend testing any cleaning solution on a small area of the arm that is not visible, to verify compatibility.

Never submerge or allow liquids to enter the arm. Wipe any cleaning agents off of the arm immediately using a water-dampened cloth. Dry the arm thoroughly after cleaning.

**CAUTION:** GCX makes no claims regarding the efficacy of the listed chemicals or processes as a means for controlling infection. Consult your hospital's infection control officer or epidemiologist. To clean or sterilize mounted instruments or accessory equipment, refer to the specific instructions delivered with those products.

## 12.0 Troubleshooting the VHM-P and VHM-PL Arm

Symptom	Possible Cause	Remedy
Mounted device does not appear level or parallel to the floor.	Channel not plumb. Check with level.	Adjust channel to plumb, or reinstall channel.
	Weight of device not compatible with load rating of the arm.	Mount device on arm with compatible load rating (section 3.0).
	Swivel hardware loose.	Adjust swivel tension (section 8.3).
	Pivot hardware loose.	Adjust pivot tension (section 8.4, 8.5).
	Mounting surface (e.g., wall, side of anesthesia machine, etc.) not structurally sound (does not hold mounting hardware).	Mounting surface must be reinforced or channel must be relocated.
	Channel loose at mounting surface.	Check for plumb and tighten, or relocate (reinstall) channel.
Mounted device drifts up or down.	Arm not counterbalanced correctly for weight of the device.	Perform counterbalance adjustment (section 8.1).
	Weight of mounted device not compatible with load rating range of arm.	Use arm with compatible load rating range (section 3.0).
Mounted device is difficult to move up or down.	Arm not counterbalanced correctly for weight of mounted device.	Perform counterbalance adjustment (section 8.1).
Arm pivots too freely.	Pivot tension is too loose.	Adjust pivot tension (section 8.4, 8.5).
Arm is difficult to pivot.	Pivot tension is too tight.	
Device swivels too freely.	Swivel tension is too loose.	Adjust swivel tension (section 8.3).
Device is difficult to swivel.	Swivel tension is too tight.	
Device is difficult to tilt.	Tilt tension is too tight.	Adjust tilt tension (section 8.2).
Device will not maintain tilt position.	Tilt tension is too loose.	
Arm inadvertently slides down channel.	Set screws (4) in slide are loose.	Reposition arm, tighten set screws in slide, and secure adjustable stop (section 5.2 and 5.4).
	Adjustable stop is loose or missing.	Install or secure adjustable stop (section 5.2).
VHM-PL (locking) handle actuation does not operate correctly (arm will not lock or will not unlock).	Internal problem.	Contact GCX / <a href="http://www.gcx.com">www.gcx.com</a>
VHM-PL (locking) remains un-locked.	Handle grip locked open for counter balance adjustment	Remove hex key (section 8.1)
Arm motion feels restricted or limited.	Improper cable routing is causing interference and/or cable binding.	Inspect cable routing and ensure proper anchorage, service loops, and path routing; adjust as needed (Section 9).