

VHM-25™ Channel Mount

Variable Height Mount - 25 with Horizontal Extension

WS-0008-02

- Small profile - space saving design
- 7 - 20 lb / 3.2 - 9.1 kg Weight limit
- Tilt, swivel and pivot adjustments
- Portrait/landscape adjustment
- 100/75 mm VESA compatible
- Smooth continuous surface with minimal seams for easy cleaning
- Flush fold-over ability for minimal foot print
- Dual pivot adjustment
- 7"/17.8 cm Horizontal extension
- 21.8"/55.4 cm maximum reach
- 5"/12.7 cm minimum reach when in the flush position
- 12"/30.5 cm Height adjustment range
- Product weight: 6.2 lbs/2.8 kg

Note: Patent Pending

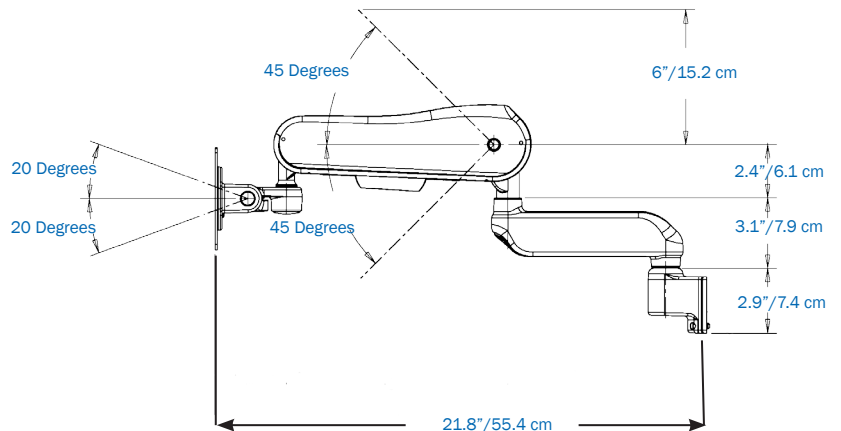
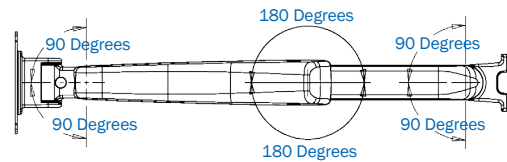

VHM-25

Horizontal Extension

Angled Extension

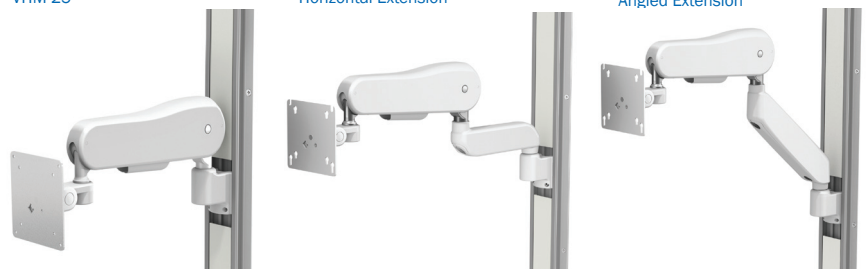

3875 Cypress Drive
 Petaluma, California 94954-5635
 United States
 800-228-2555
 707-773-1100 outside US
 707-773-1180 fax

Postbus 10462
 5000 JL Tilburg
 Netherlands
 +31 (0) 88 627 2600
 +31 (0) 88 627 2609 fax

No. 7, Lane 116, Wugong 3rd Road
 Wugu Township, Taipei County 248
 Taiwan (R.O.C.)
 +01 707-773-1100
 +01 707-773-1180 fax

gcx.com
 one tool. one source.