

VHM-P (Non-Locking) Variable Height Arm with 8"/20.3cm or 14"/35.6cm Extension for Flat Panel / Keyboard Bracket (L Brackets) and Fixed Angle Front End Operation Guide

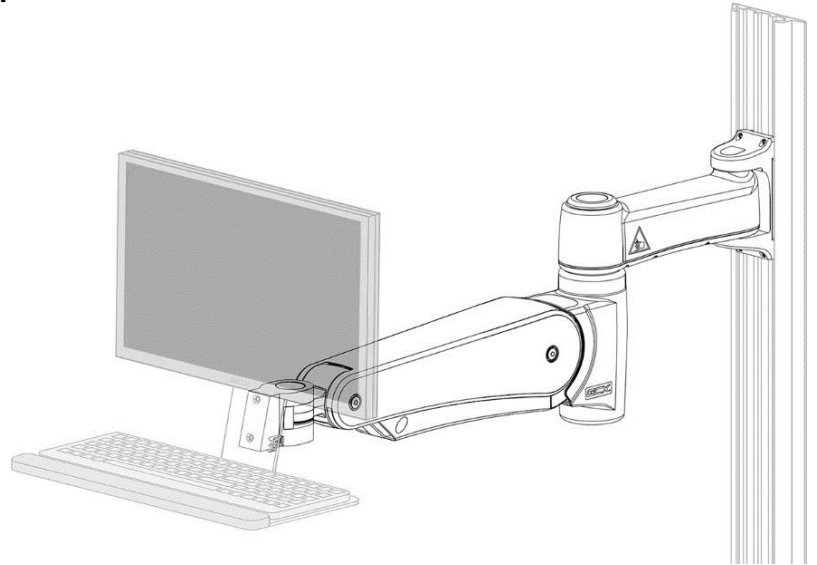

Safety Label Locations (VHM-P Series Arms)

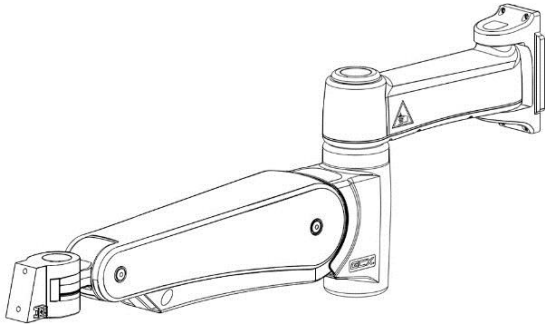
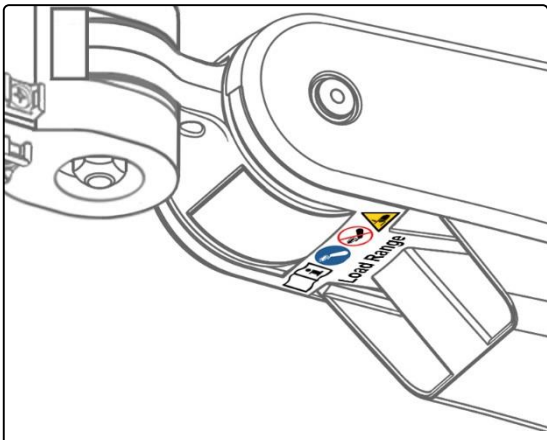
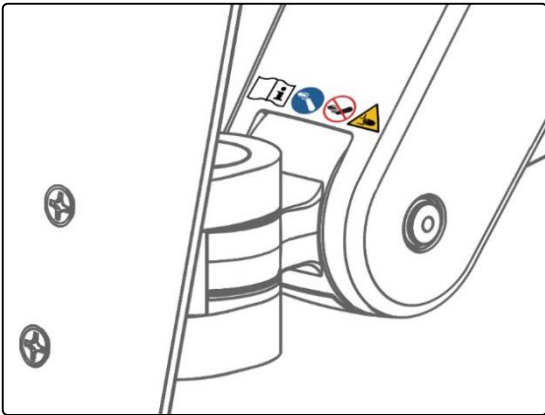

Refer to Installation Guide for additional information.



Remove the Device only when the Arm is at the highest position.



Do not remove device when arm is in a lowered position.



Potential pinch points that may cause personal injury.

Counter Balance Load Range:
25 - 45 lbs / 11.3 - 20.4 kg
or
15 - 30 lbs / 6.8 - 13.6 kg

