

Installation Guide

Power Supply Holster with PolyClamp Interface – Clamp Diameter range: .75” – 2.25”/19mm – 57mm
(Refer to qualified personnel)

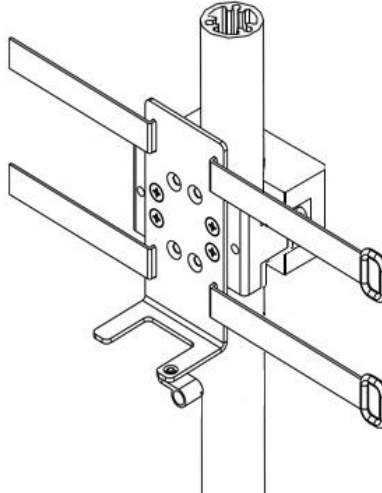

The purpose of this guide is to:

Describe attachment of Power Supply Holster with PolyClamp Interface onto a Post.

Parts Reference

The following parts and hardware are included in this installation kit (Hardware not shown).

Item #	Description	Qty
1	Power Supply Holster	1
2	PolyClamp Hardware	1
3	1/4-20 x 1" Socket Head Cap Screw (SHCS)	2
4	1/4-20 x 1.50" SHCS	2
5	1/4-20 x 2.50" SHCS	2

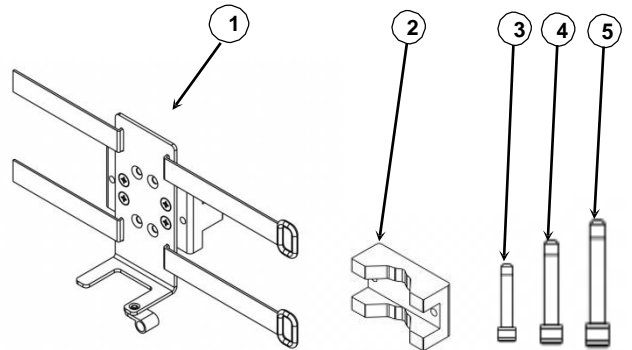

Tools required

- 3/16" Hex Wrench (Provided)



WARNING: Do not position Power Supply above a patient.

Power Supply Holster mounting instructions

1. Identify post diameter and choose proper screw length (see chart below).
2. Using a 3/16" hex wrench, alternately tighten the screws until Basket is secure on post. The side gaps between the Mount Clamp and Clamping Block should be nominally equal.

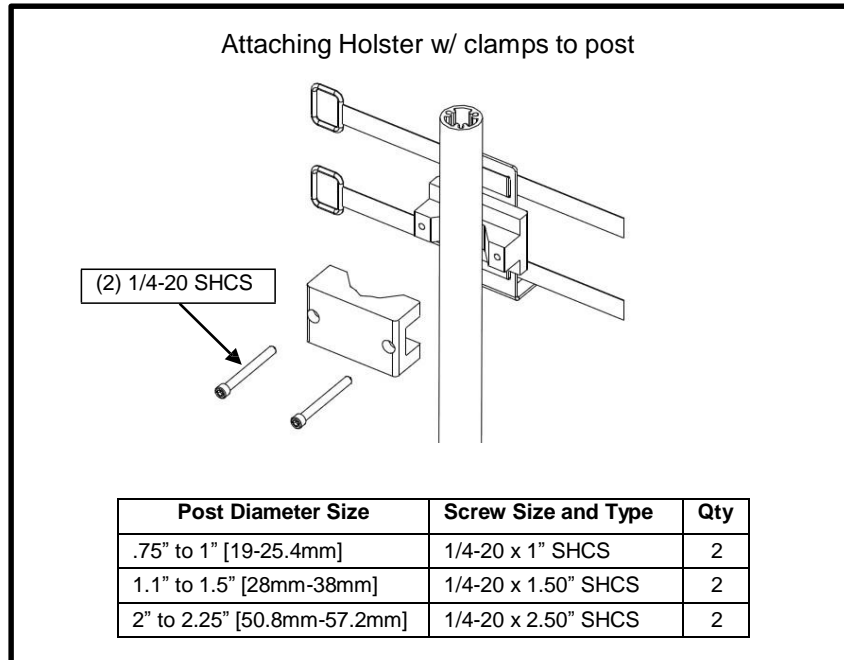

Routine Maintenance

Periodically inspect all fasteners associated with the mounting system. Tighten or adjust fasteners as necessary for Optimal operation and safety.

Cleaning the Mounting Assembly

1. The mounting assembly may be cleaned with most mild, non-abrasive solutions commonly used in the hospital environment (e.g. diluted bleach, ammonia, or alcohol solutions).
2. The surface finish will be permanently damaged by strong chemicals and solvents such as acetone or trichloroethylene.
3. Do not use steel wool or other abrasive material.
4. Damage caused by the use of unapproved substances or processes will not be warranted. It is recommended that you test any cleaning solution on a small area of the mounting assembly that is not visible to verify compatibility.
5. Never submerge or allow liquids to enter the mounting assembly. Wipe any cleaning agents off of the mounting assembly immediately, using water dampened cloth. Dry the mounting assembly thoroughly after cleaning.

CAUTION: GCX makes no claims regarding the efficacy of the listed chemicals or processes as a means for controlling Infection. Consult your hospital's infection control officer or epidemiologist. To clean or sterilize mounted devices or Accessory equipment, refer to the specific instructions delivered with those products before installing the arm in the Channel.