

Installation Guide

Philips X2/MP2/X3/MX100 Tilt/Swivel Post/Rail Clamp
(Post 0.75" [19 mm] to 1.5" [38 mm] Diameter) or Rail (10 mm x 25 mm)
Maximum Load 6.8 kg / 15 lbs

The purpose of this guide is to:

1. Describe attachment of Clamp Assembly to mounting plate (page 2).
2. Describe mounting of X2/MP2/X3/MX100 on post and rail (page 3).

Installation Note: Mounting plate supplied by Philips.



Parts Reference

The following parts and hardware are included with this installation kit (hardware not shown):

Item #	Description	Qty
1	Tilt/Swivel Clamp Assembly	1
2	M4 x 14 mm Pan Head Machine Screw (PHMS)	2
3	M4 x 10 mm PHMS	2

Tools Required: Phillips screwdriver (not provided).

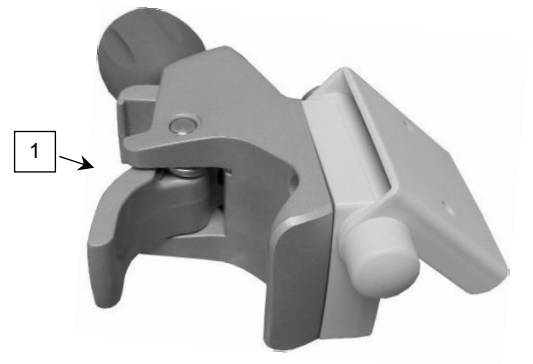

Attaching Clamp Assembly to Mounting Plate, Battery Extension or IntelliVue Dock (supplied by Philips)

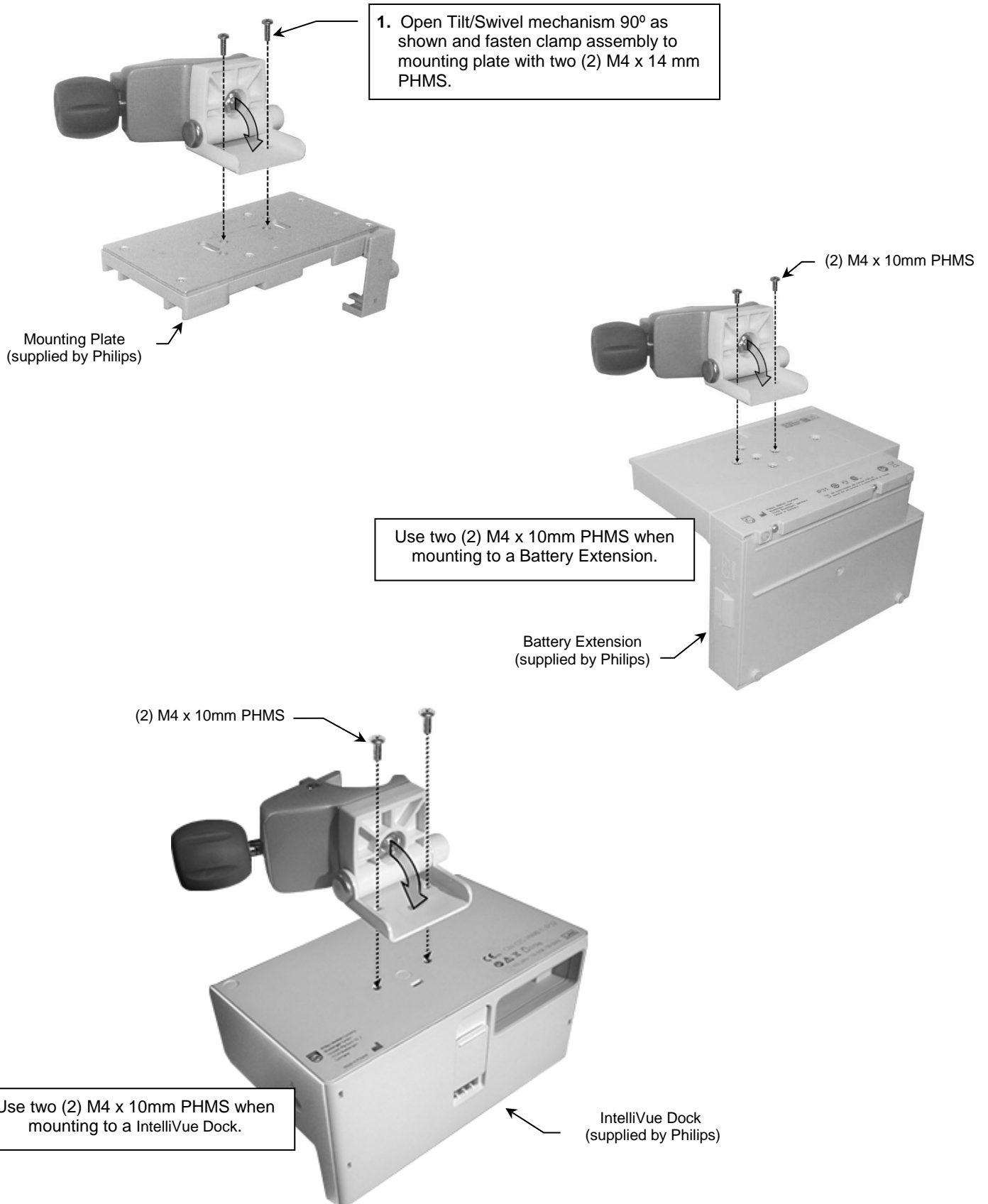

Mounting on Post

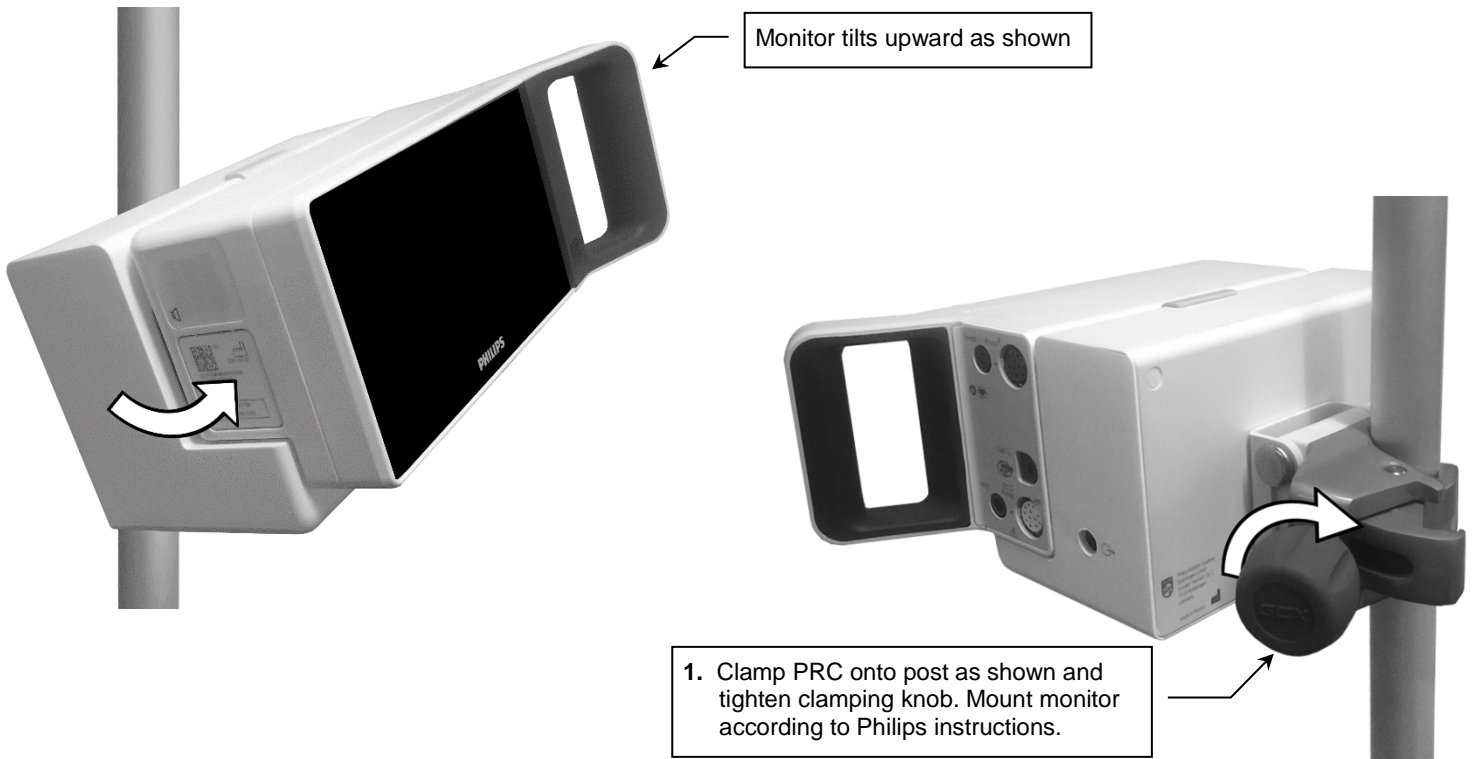

Mounting on Rail

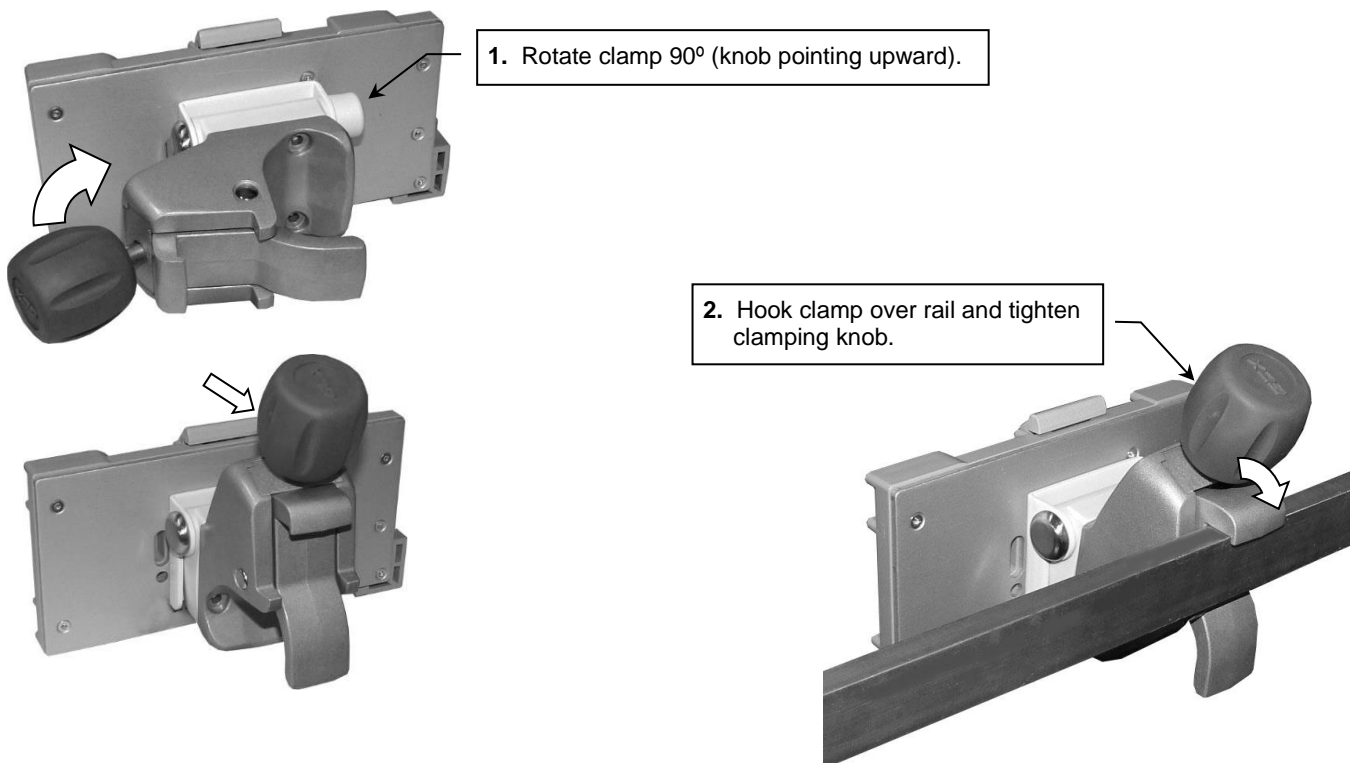

Routine Maintenance

Periodically inspect all mounting hardware. Tighten or adjust as necessary for optimal operation and safety.

Cleaning the Mounting Assembly

CAUTION: GCX makes no claims regarding the efficacy of the listed chemicals or processes as a means for controlling infection. Consult your hospital's infection control officer or epidemiologist. To clean or sterilize mounted instruments or accessory equipment, refer to the specific instructions delivered with those products.

1. The mounting assembly may be cleaned with most mild, non-abrasive solutions commonly used in the hospital environment (e.g. diluted bleach, ammonia, or alcohol solutions).
2. The surface finish will be permanently damaged by strong chemicals and solvents such as acetone and trichloroethylene.
3. Do not use steel wool or other abrasive material to clean the mounting assembly.
4. Damage caused by the use of unapproved substances or processes will not be covered by warranty. We recommend testing of any cleaning solution on a small area of the mounting assembly that is not visible to verify compatibility.
5. Never submerge or allow liquids to enter the mounting assembly. Wipe any cleaning agents off the mounting assembly immediately using a water-dampened cloth. Dry all mounting assemblies thoroughly after cleaning.