

Installation Guide

Philips FM 20/30 Upgrade Kit for PH-0065-80

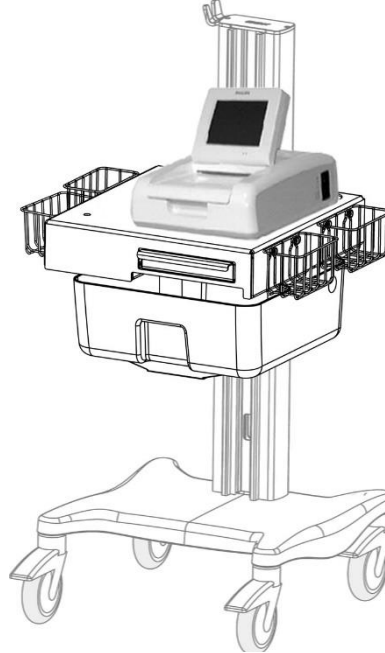

15 lbs
6.8 kg
Max Weight

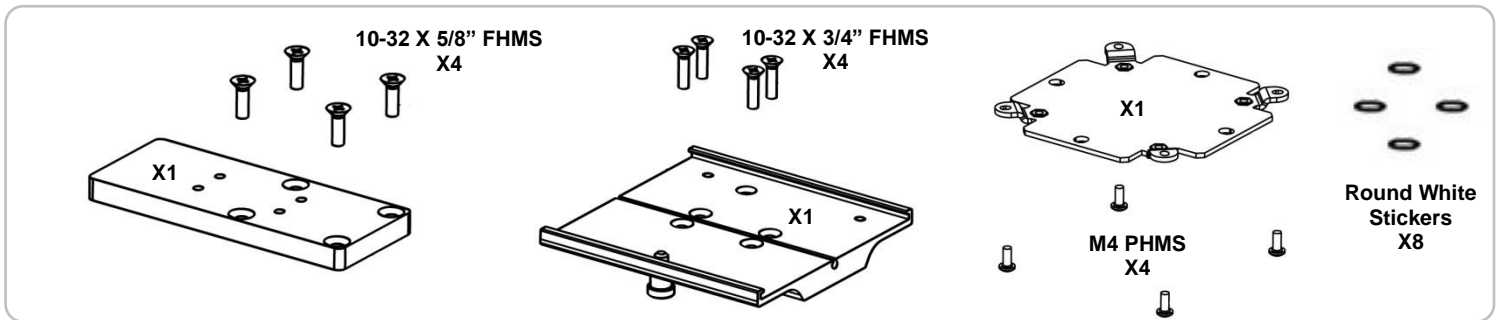

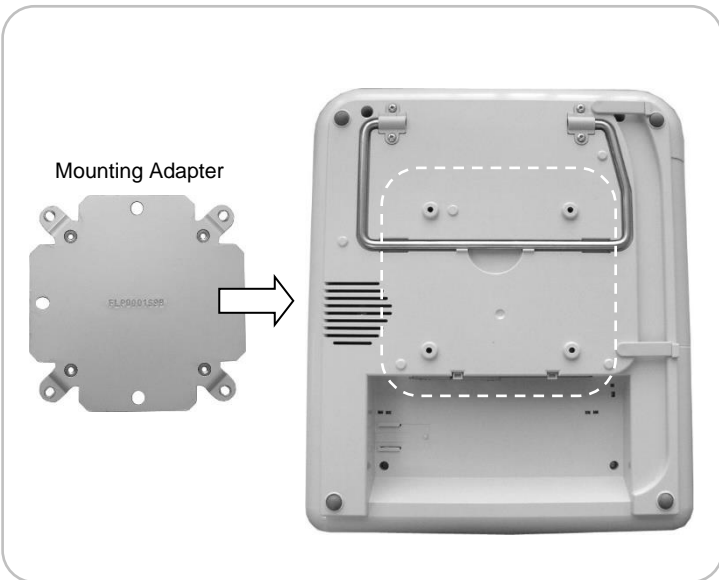
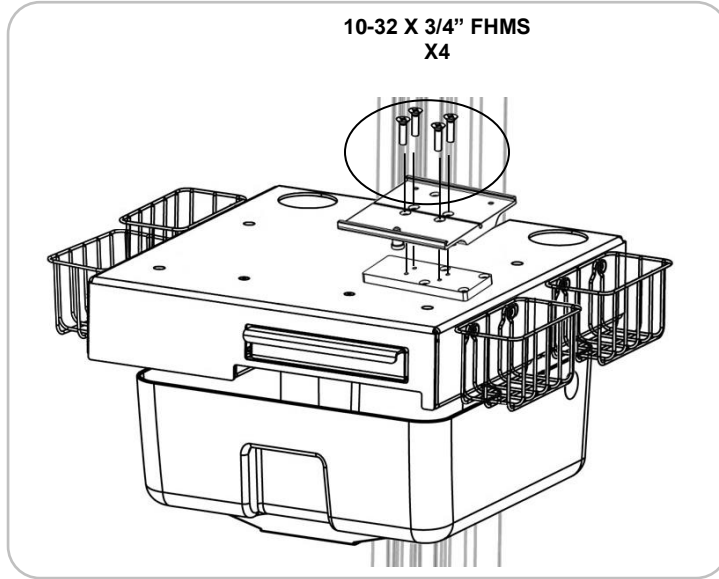
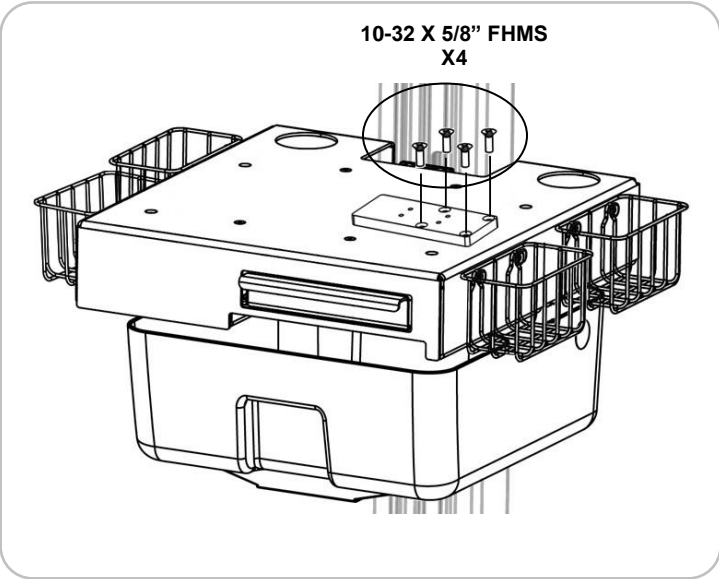
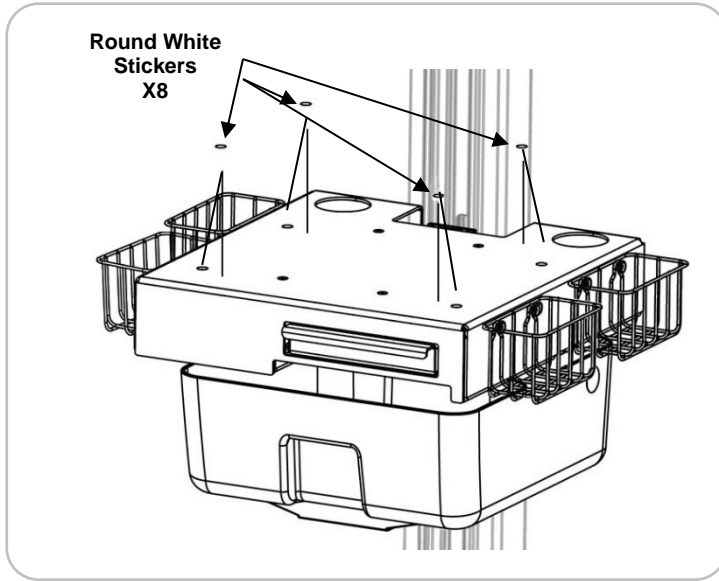
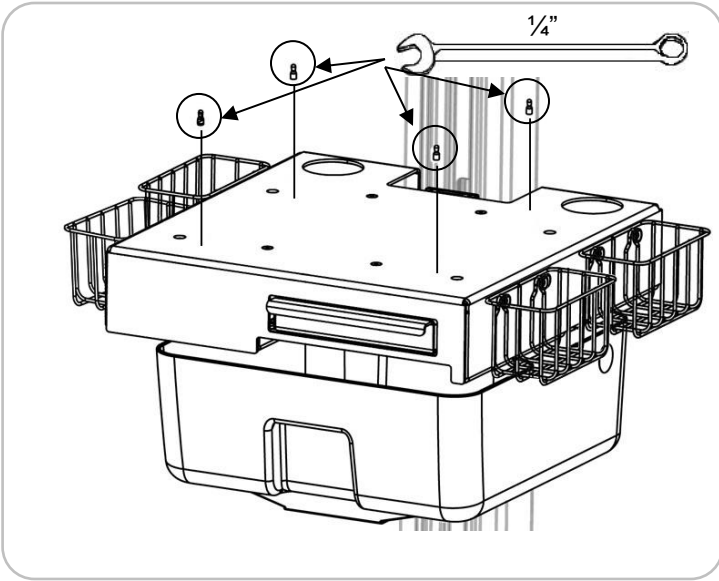

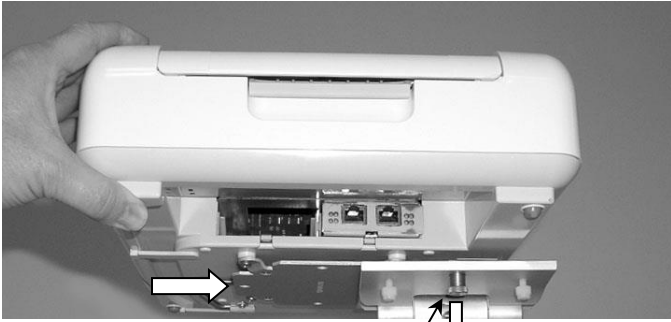

Pull and Release Plunger

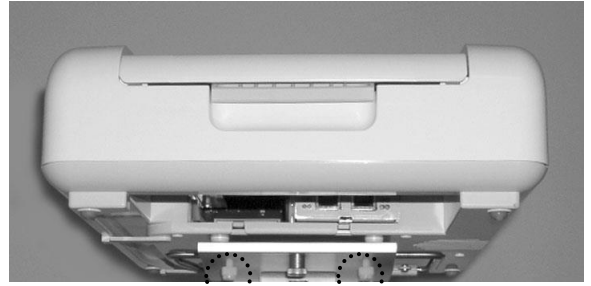

Tighten Nylon
Screws