

Installation Guide

GE/Datex Avance - Aisys 13" Extended Left Side Channel

The purpose of this guide is to:

- Describe mounting the Avance - Aisys 13" Extended left side Channel.



Parts Reference

The following parts are included in this installation kit :

Item #	Description	Qty
1	13" Extended Channel	1
2	1/8" Hex Wrench	1

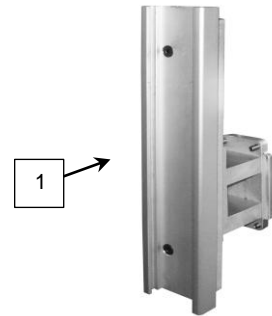

Tools Required:

- 1/8" Hex Wrench (supplied)



Warning – Do not overload Channel. Ensure that the weight of the equipment being mounted does not exceed the GE/Datex published load limits for the Datex Channel. Failure to adhere to this warning may result in damage to equipment or injury.

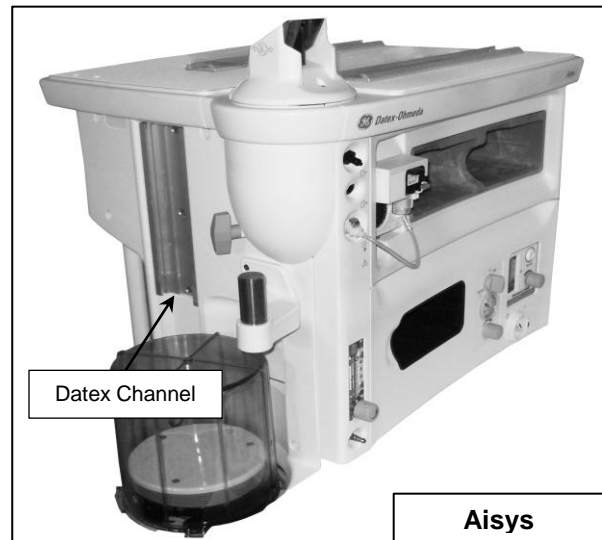

Installing 13" Offset Channel on Avance

1. Slide 13" Extended Channel into the left side Datex/Avance Channel (below left).
2. Using a 1/8" Hex wrench, tighten the (4) Set Screws to secure (below right).



Installing 13" Offset Channel on Aisys

1. Carefully slide the Breathing Unit Assembly away from Aisys to allow Extended Channel installation.



- Slide the 13" Extended Channel up into the left side Datex/Aisys Channel and move to top.

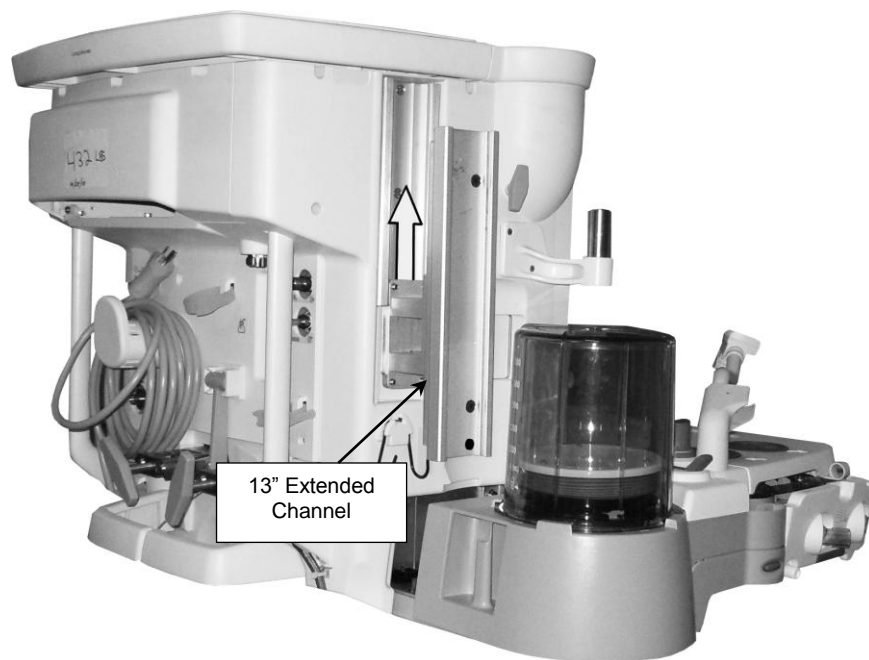

- Using a 1/8" Hex wrench, tighten the (4) Set Screws on the Extended Channel to secure position.
- Close Breathing Unit Assembly.

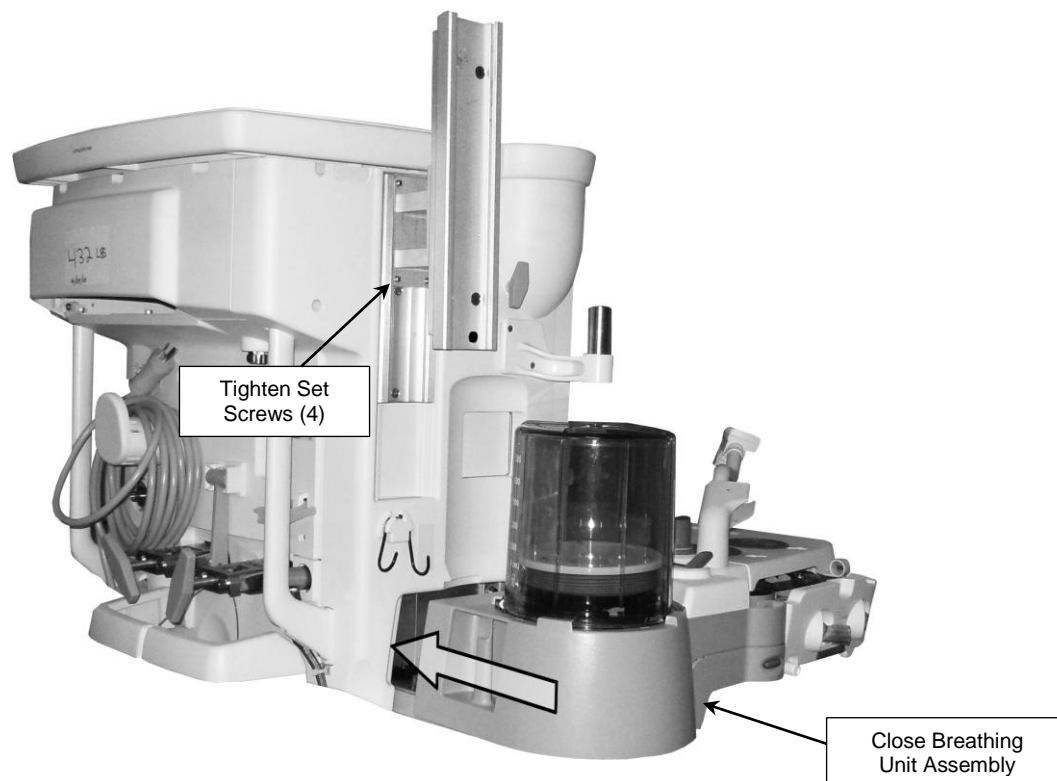

Routine Maintenance

Periodically check all mounting hardware. Tighten as necessary for optimal operation and safety.

Cleaning the Mounting Assembly

1. The mounting assembly may be cleaned with most mild, non-abrasive solutions commonly used in the hospital environment (e.g. diluted bleach, ammonia, or alcohol solutions).
2. The surface finish will be permanently damaged by strong chemicals and solvents such as acetone and trichloroethylene.
3. Do not use steel wool or other abrasive material to clean the mounting assembly.
4. Damage caused by the use of unapproved substances or processes will not be covered by warranty. We recommend testing any cleaning solution on a small area of the mounting assembly that is not visible to verify compatibility.
5. Never submerge or allow liquids to enter the mounting assemblies. Wipe any cleaning agents off the mounting assembly immediately using a water-dampened cloth. Dry all mounting assemblies thoroughly after cleaning.

CAUTION: GCX makes no claims regarding the efficacy of the listed chemicals or processes as a means for controlling infection. Consult your hospital's infection control officer or epidemiologist. To clean or sterilize mounted instruments or accessory equipment, refer to the specific instructions delivered with those products.