

Installation Guide

Philips MP90 VHM™ Wall Mount Kit

The purpose of this guide is to describe the procedures for installing the MP90 VHM™ Wall Mount Kit.



Table of Contents

Section 1.0: Mounting the VHM-Series Arm	2
1.1 Parts Reference	2
1.2 Mounting the VHM Arm in the Wall Channel	3
1.3 Installing the Tilt Adjustment Lever	4
Section 2.0: Attaching Remote Speedpoint/Alert Brackets & Mounting the Display	5
2.1 Attaching Remote Bracket and Mounting 15" (M8031B) Display	6
2.2 Attaching Remote Bracket and Mounting 17" (M8033C) Display	7
2.3 Attaching Alert Bracket and Reinforcing Bar to Remote Bracket	8
2.4 Mounting the Devices and Power Supply Holster	9
2.4.1 Mounting External Alert Device with 15" (M8031B) Display	9
2.4.2 Mounting External Alert Device with 17" (M8033C) Display	9
2.5 Mounting the Remote Speedpoint	10
2.6 Attaching Power Supply Holster (not supplied) to Remote Bracket	11
Section 3.0: Attaching Down Post & Utility Hook to the VHM Arm	12
Section 4.0: Counterbalance Adjustment	13
Section 5.0: Cable Management	14

Section 1.0: Mounting the VHM-Series Arm

This section covers mounting of the VHM Arm.

1.1 Parts Reference

The following parts and hardware are included in the installation kit (hardware not shown):

Item #	Description	Qty
1	VHM Arm with 6" Riser and Philips Mounting Plate	1
2	Lever, Tilt Adjustment	1
3	Remote Speedpoint/External Alert/Display Mounting Kit (see page 5 for parts)	1
4	Down Post Kit, 6" and 12" Posts	1
5	Utility Hook Kit	1
6	Wall Channel Cover, 16"	1
7	1/8" Hex Wrench	1
8	1/4" Hex Wrench	1
9	5/32" Hex Wrench	1
10	9/64" Hex Wrench	1
11	Cable Guide	1

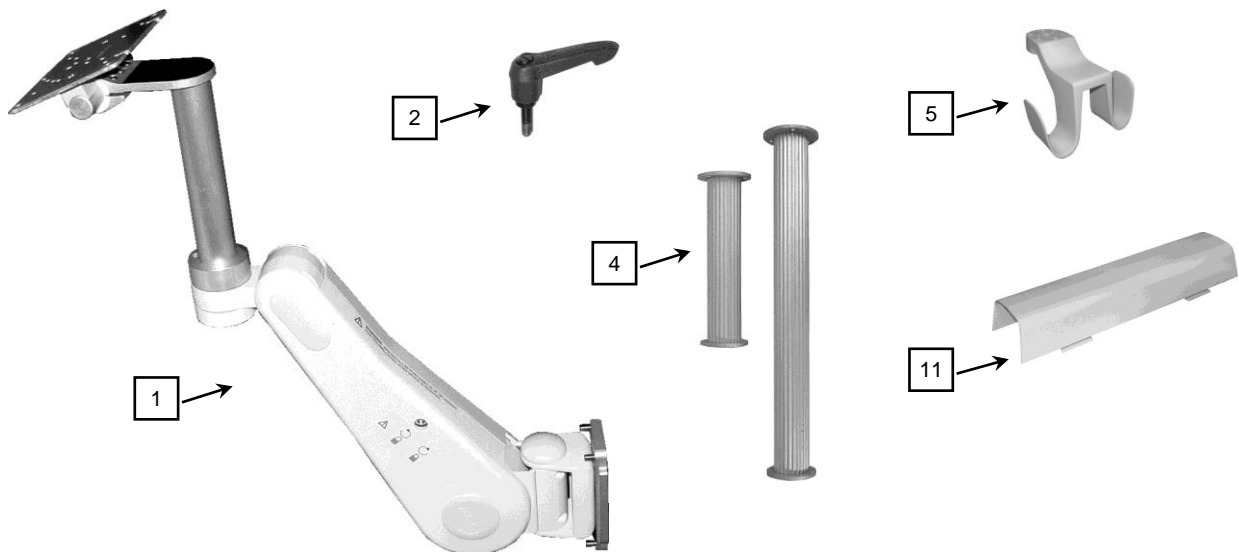

Tools Required

Phillips screwdriver (not provided); 9/64", 1/8", and 1/4" hex wrenches (provided).

1.2 Mounting the VHM Arm in the Wall Channel

Mounting VHM Arm in Wall Channel

1. Thread the Height Locking Lever into the mounting hole in the right side of the Arm. The Lever operates by turning clockwise to tighten or counterclockwise to loosen. Ensure that the Locking Lever is in the locked position before mounting the Arm in the channel.

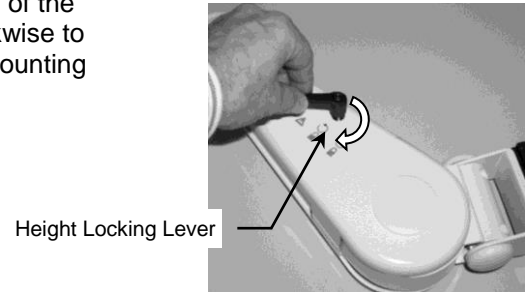

2. While supporting the bottom of the Arm, guide the Slide into the top of the wall channel (below left) and move Arm to required mounting position.
3. Using the 1/8" hex wrench provided, tighten four (4) set screws in Slide to secure position of Arm (below right).

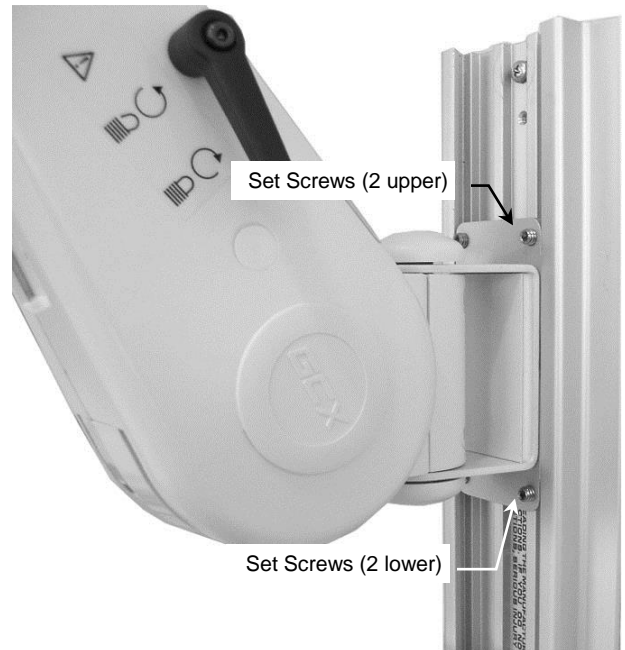

1.3 Installing the Tilt Adjustment Lever

Installation Note: Do not install the Tilt Adjustment Lever if you will be mounting a M8031B (15") display with Power Supply Holster. Tilt tension adjustment (if using Philips-supplied equipment) will be accomplished using a 9/64" hex wrench to loosen/tighten the two (2) socket head cap screws on top of the Manual Tilt Clamp.

1. Using the 1/4" hex wrench, remove the tilt limit screw (right) from the Manual Tilt Clamp.
2. Screw the Tilt Adjustment Lever (clockwise) into the threaded hole on top of the Manual Tilt Clamp. **Note:** It may be necessary to tilt the Mounting Plate down to install the Tilt Lever. Adjust tilt tension screws (below center) if necessary.

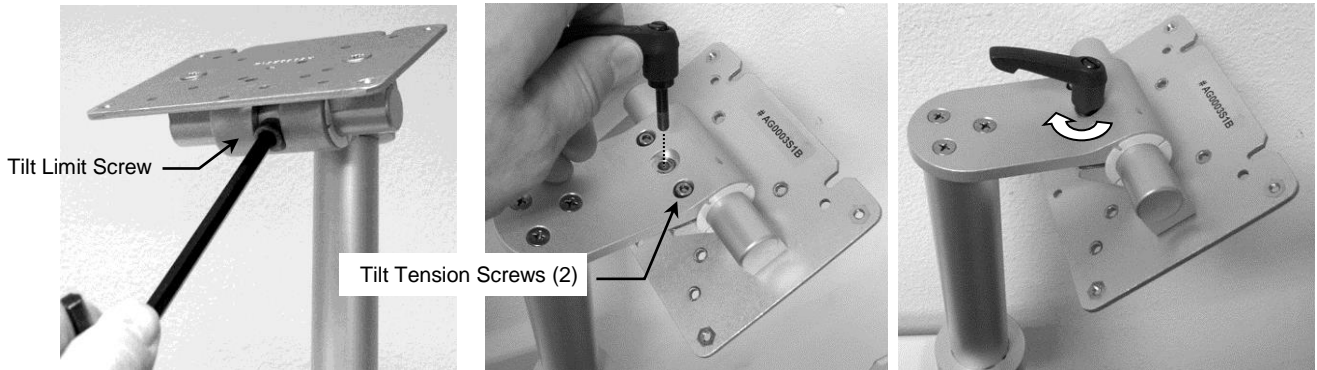

Note: The Tilt Adjustment Lever is a multi-position clamping lever that operates by lifting, rotating, and releasing the handle.

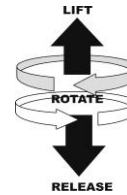

Section 2.0: Attaching Remote Speedpoint/Alert Brackets & Mounting the Display

Parts Reference

The following parts and hardware are included in this installation kit (hardware not shown):

Item #	Description	Qty
1	Remote Bracket	1
2	Alert Bracket	1
3	Remote Speedpoint Adapter	1
4	Reinforcing Bar	1
5	VESA Mounting Adapter, 100mm to 75mm	1
6	Spacer, 17" Display Mounting (P/N AG0019S22A)	1
7	Spacer, 15" Display Mounting (P/N AG0019S15A)	1
8	M4 x 6mm Flat Head Machine Screw (FHMS)	2
9	M4 x 8mm Pan Head Machine Screw (PHMS)	10
10	M4 x 10mm PHMS	2
11	M4 x 12mm PHMS	4
12	M4 x 16mm PHMS	2
13	M4 x 16mm FHMS	3
14	M4 x 20mm FHMS	2
15	M4 x 25mm PHMS	4
16	M4 x 40mm PHMS	2
17	Alert Spacer, 1.25" Aluminum	2
18	Spacer, 1/2" Nylon	2
19	#8 Retention Washer	2

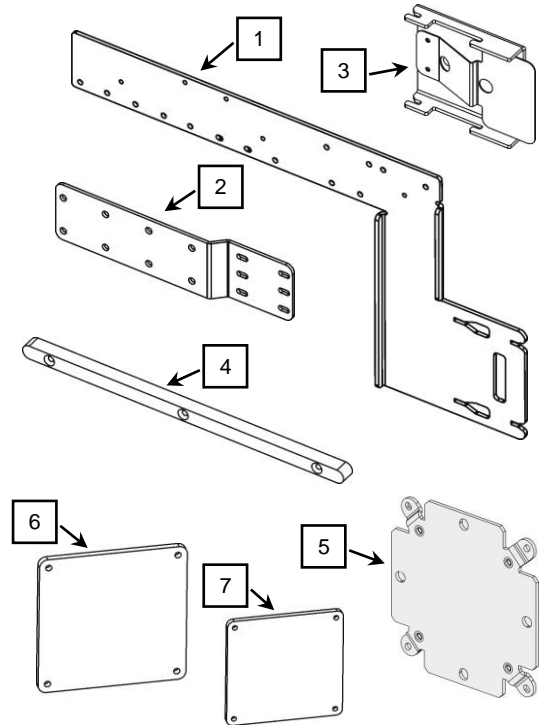

Tools Required

Phillips screwdriver (not provided).

Installation Reference – Remote Bracket Mounting Holes

Mounting holes are identified by shaded areas shown below:

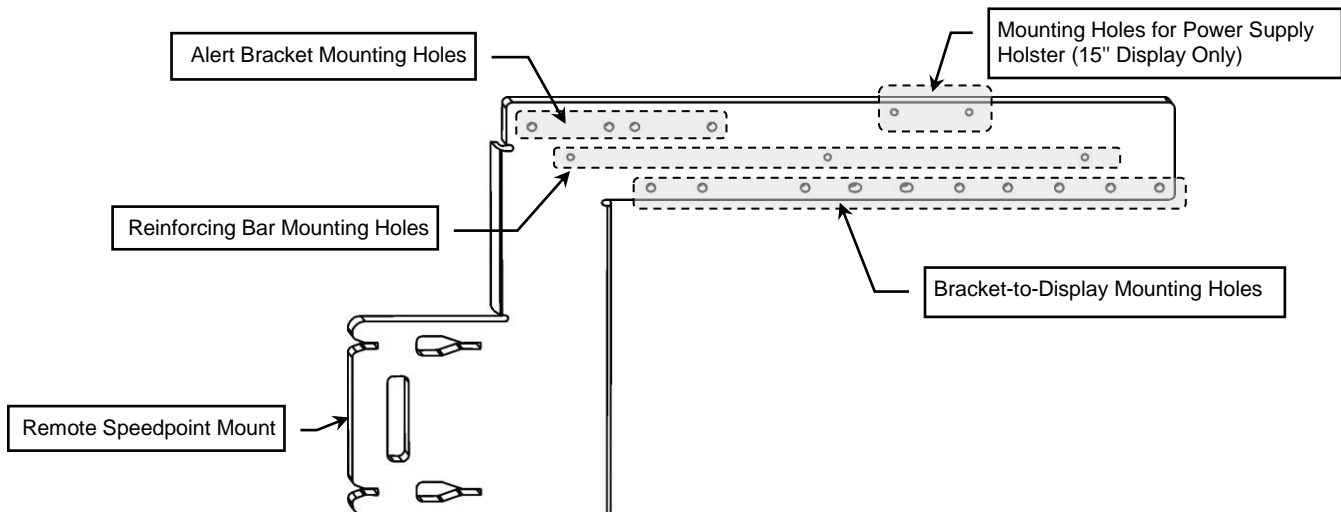

2.1 Attaching Remote Bracket and Mounting 15" (M8031B) Display

The following attachment procedures are for right-side mounting of both Remote and Alert devices on the M8031B display. The mounting holes shown in the following illustrations are typical. The actual application may require the use of different mounting holes.

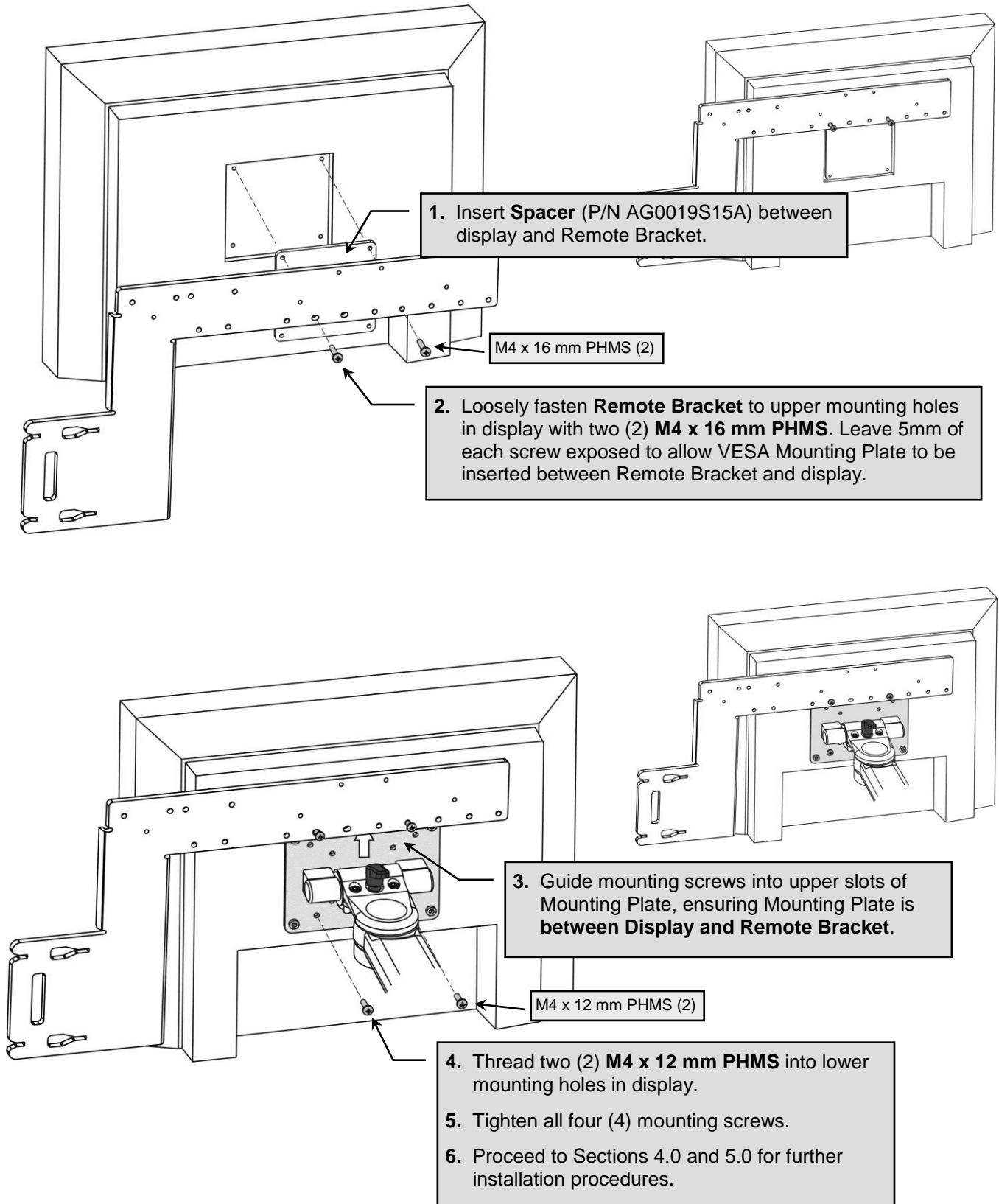

2.2 Attaching Remote Bracket and Mounting 17" (M8033C) Display

The following attachment procedures are for right-side mounting of both Remote and Alert devices on the M8031C display. The mounting holes shown in the following illustrations are typical. The actual application may require the use of different mounting holes.

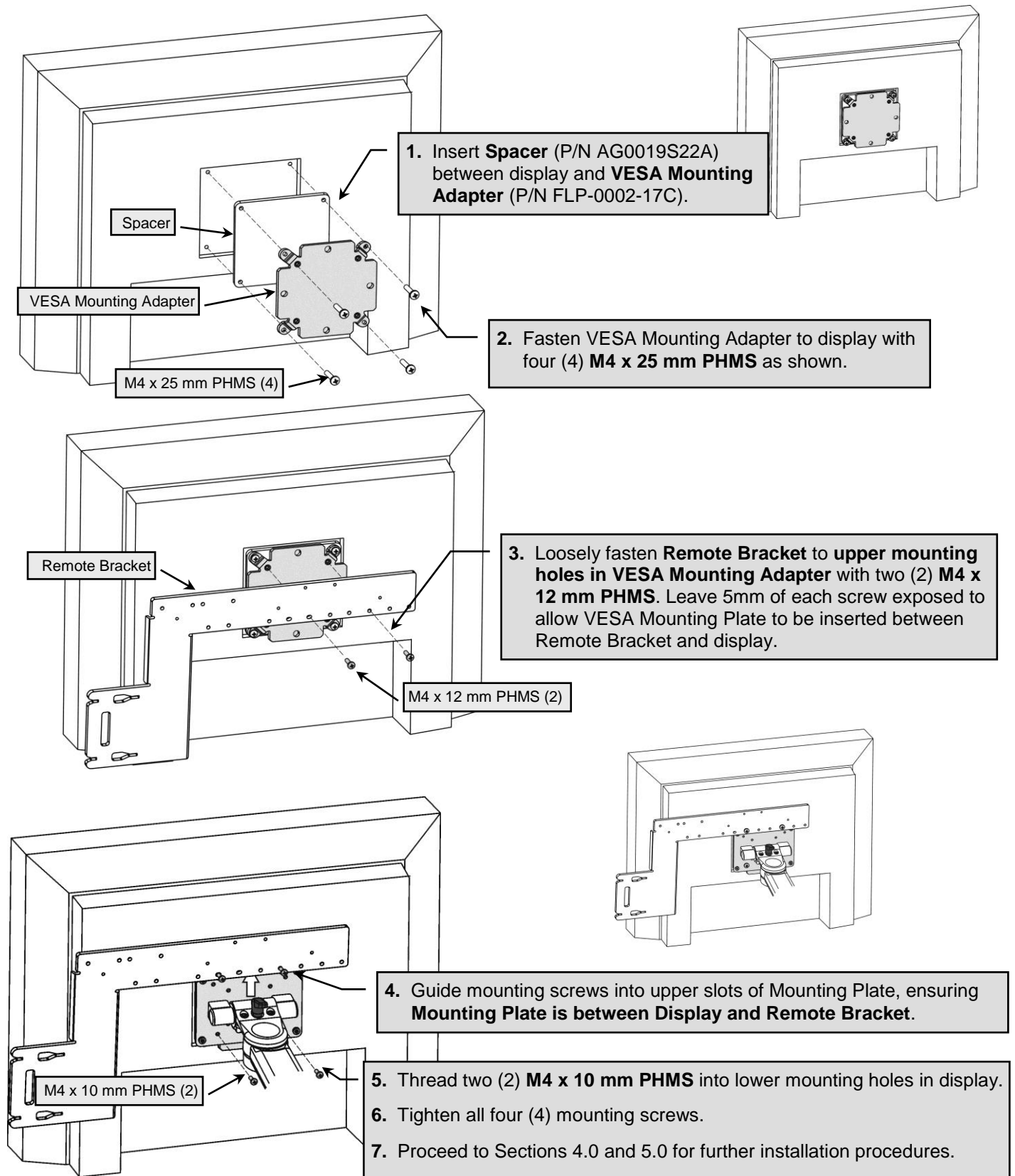

2.3 Attaching Alert Bracket and Reinforcing Bar to Remote Bracket

These procedures apply to both 15" and 17" displays.

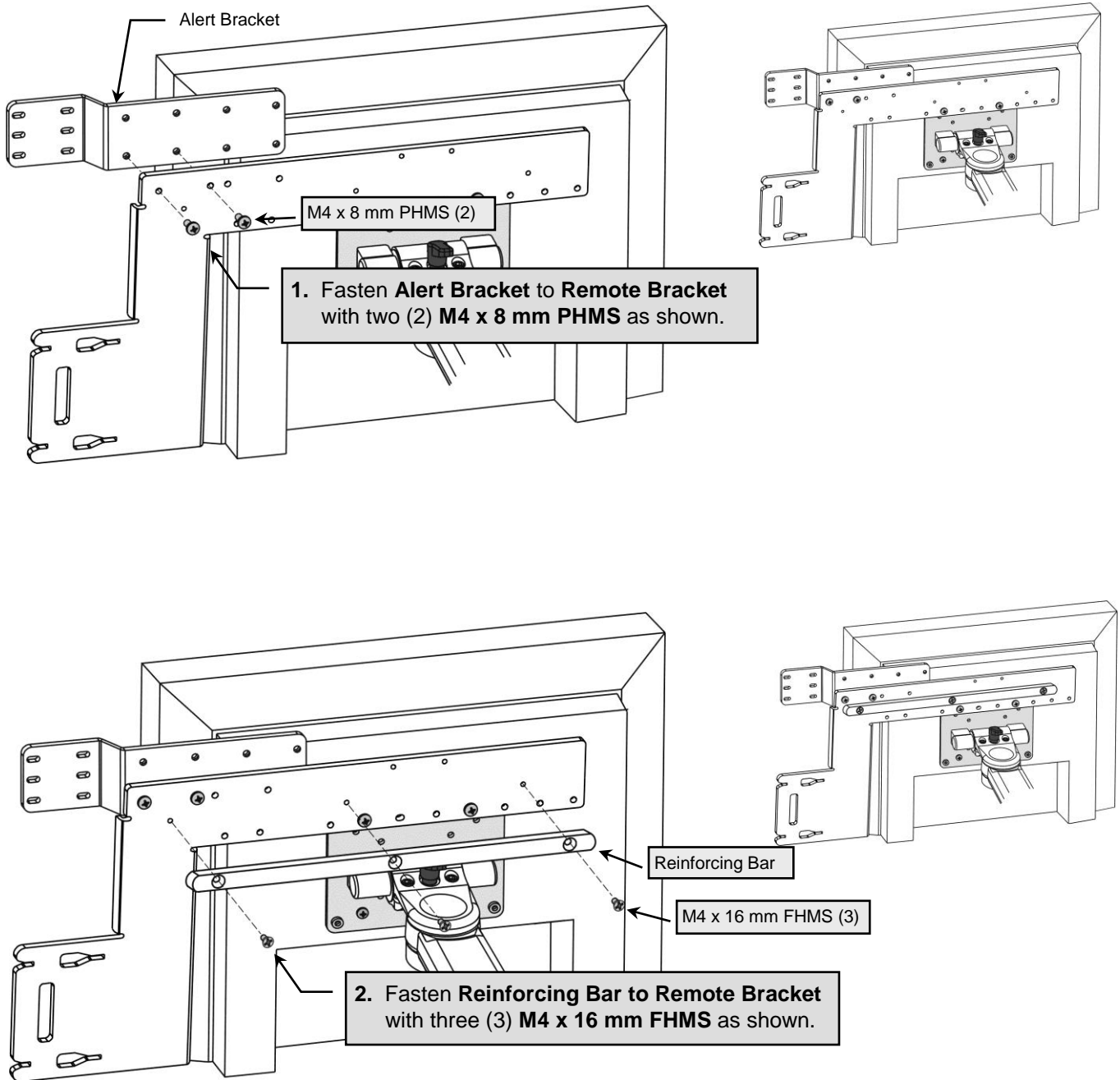

2.4 Mounting the Devices and Power Supply Holster

2.4.1 Mounting External Alert Device with 15" (M8031B) Display

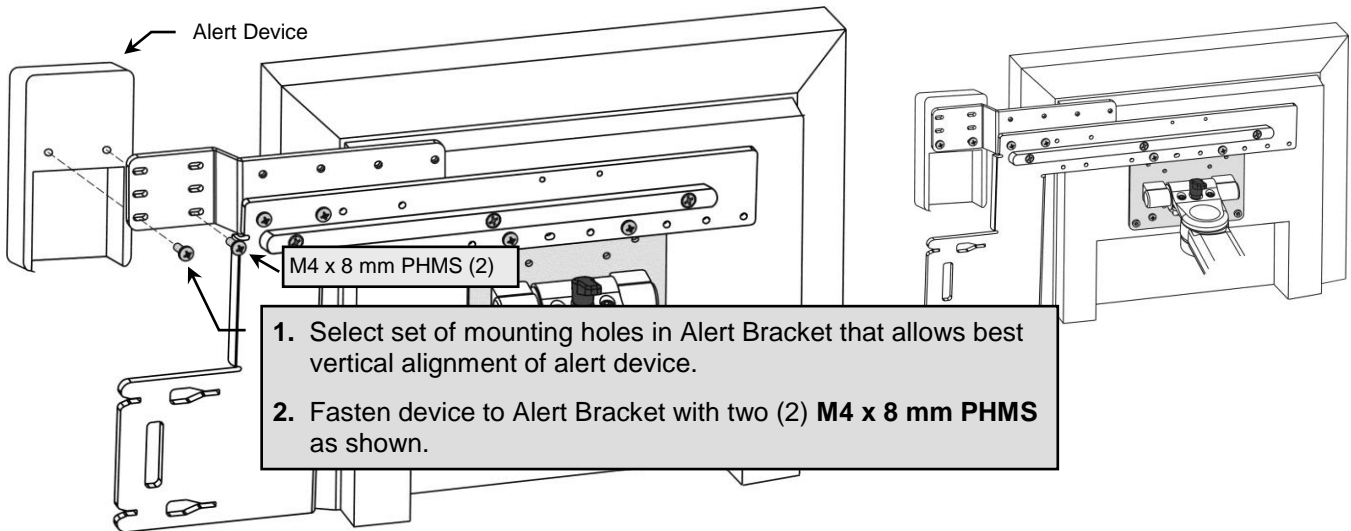

2.4.2 Mounting External Alert Device with 17" (M8033C) Display

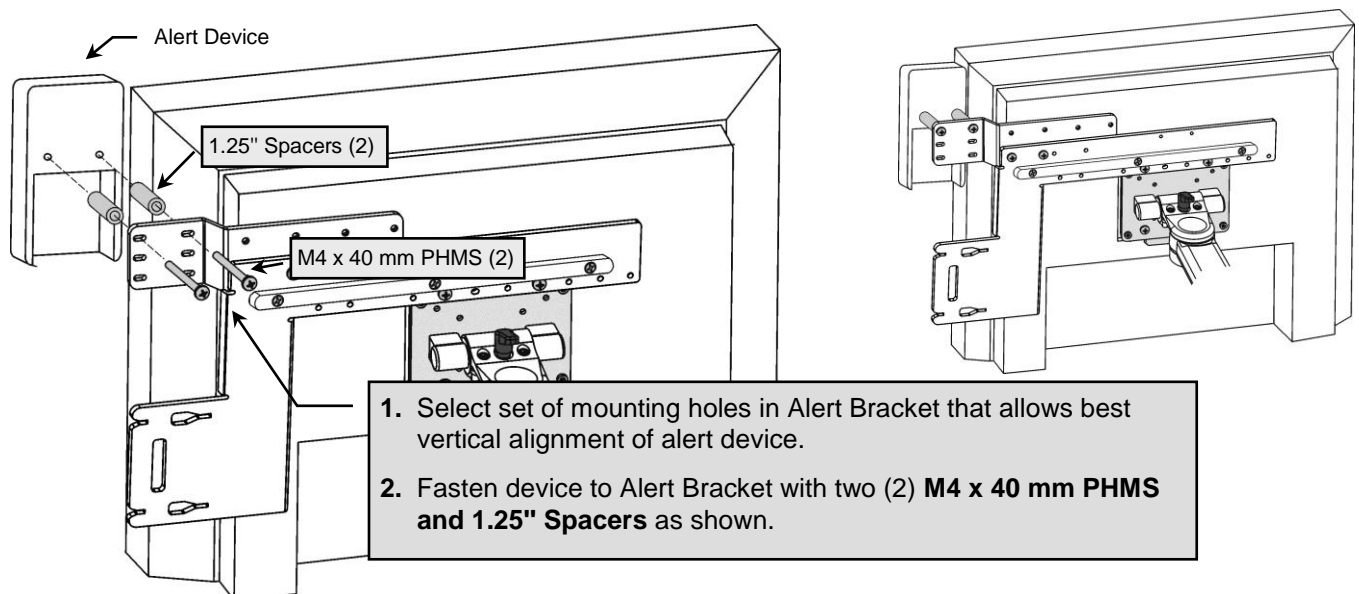

2.5 Mounting the Remote Speedpoint

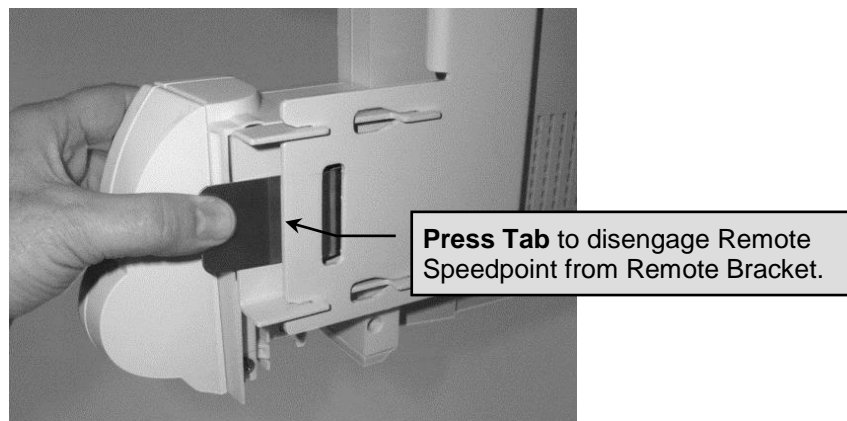
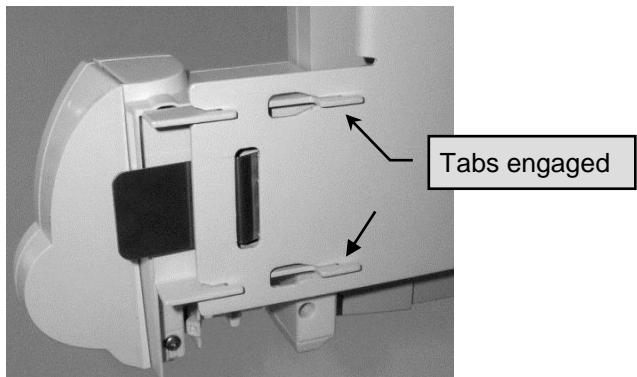
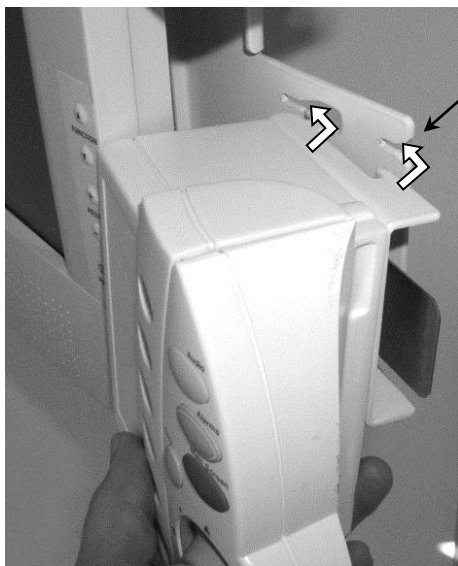
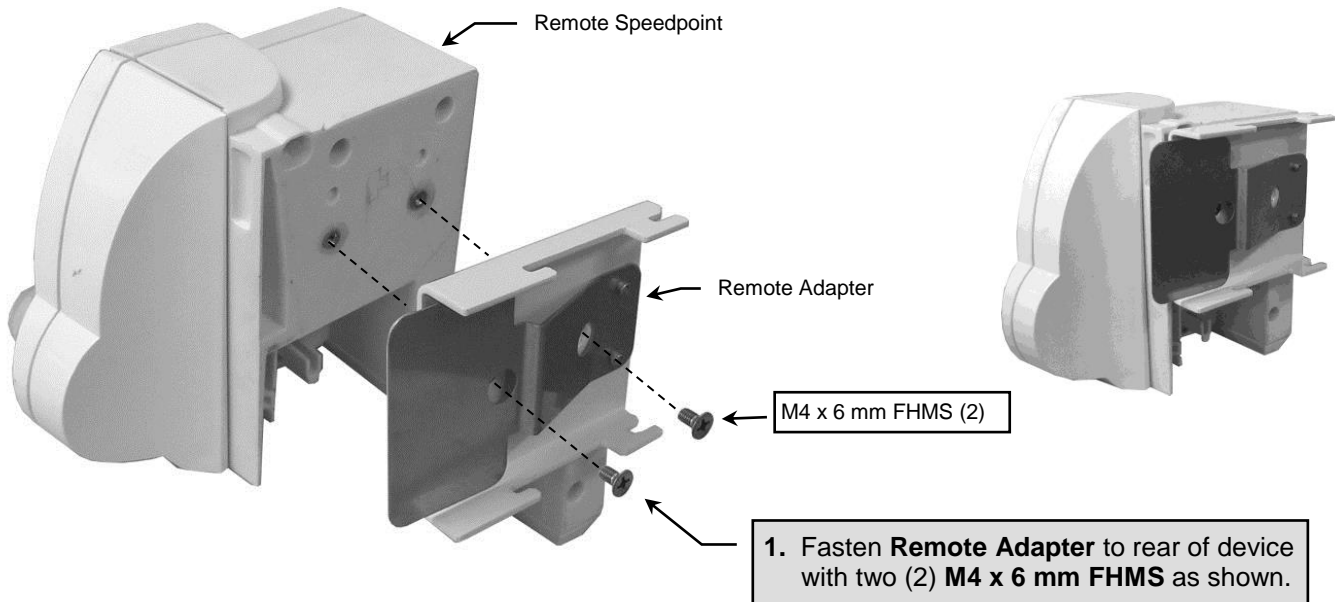

2.6 Attaching Power Supply Holster (not supplied) to Remote Bracket

This procedure applies only to the 15" (M8031B) display. The Power Supply Holster is not supplied in this installation kit.

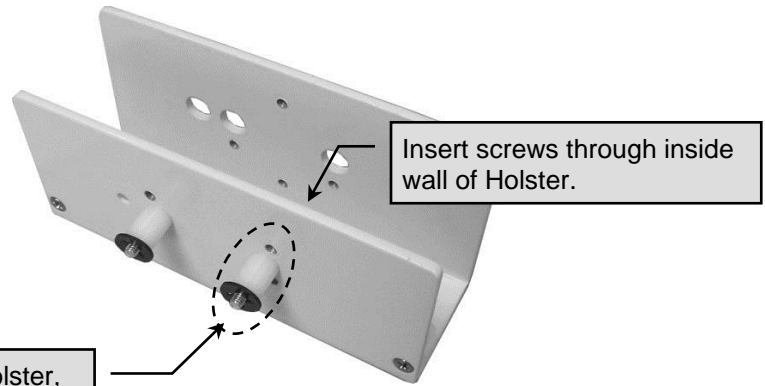

1. Insert **M4 x 20 mm FHMS (2)** from inside Holster, and assemble **Nylon Spacers (2)**, and **Retention Washers (2)** on Screws as shown.

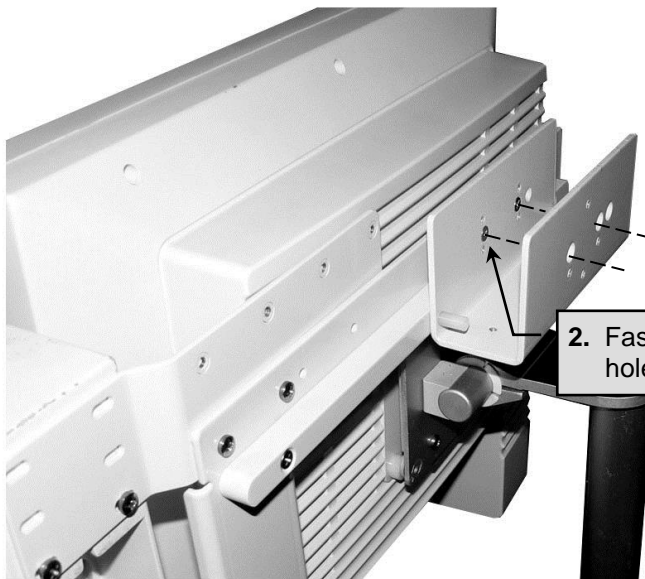
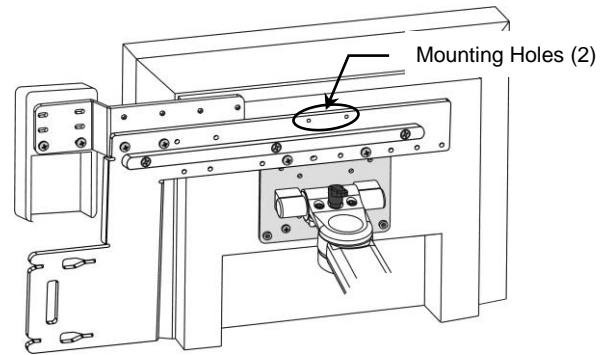

2. Fasten Power Supply Holster to two (2) mounting holes in the Remote Bracket as shown.

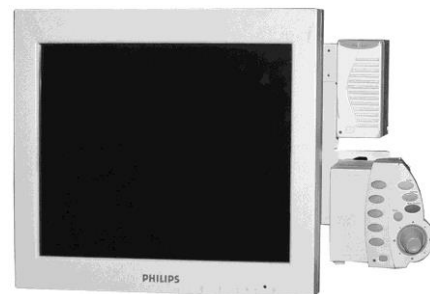

Section 3.0: Attaching Down Post & Utility Hook to the VHM Arm

Installation Note: The Down Post and Utility Hook Kits contain mounting hardware called out below. See Installation Guide DU-WMM-0006-01 and DU-WMM-0006-04 for additional information.

Tools Required: Phillips screwdriver (not provided), 5/32" hex wrench (provided).

1. Remove the round plastic bolt cap from the bottom front end of the arm.
2. Using the 5/32" hex wrench provided, fasten the Post (6" or 12") to the Swivel Cup with three (3) #10-32 x 3/8" SHCS.

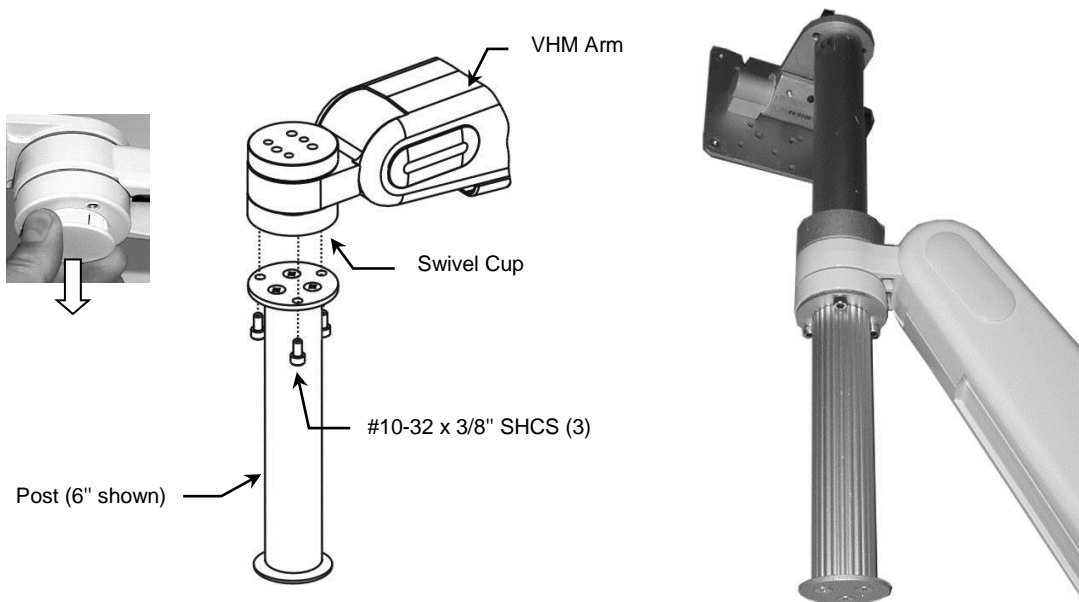

3. Using a Phillips screwdriver, unscrew Lower Post Disc from bottom end of Down Post (below left).
4. Align the offset 3-hole mounting pattern in Cable Hook with mounting holes in bottom of Down Post. Fasten Cable Hook to Post with two (2) #10 x 5/8" PHSMS in the inner holes and one (1) #10 x 1-1/4 PHSMS in the outer hole as shown below right.

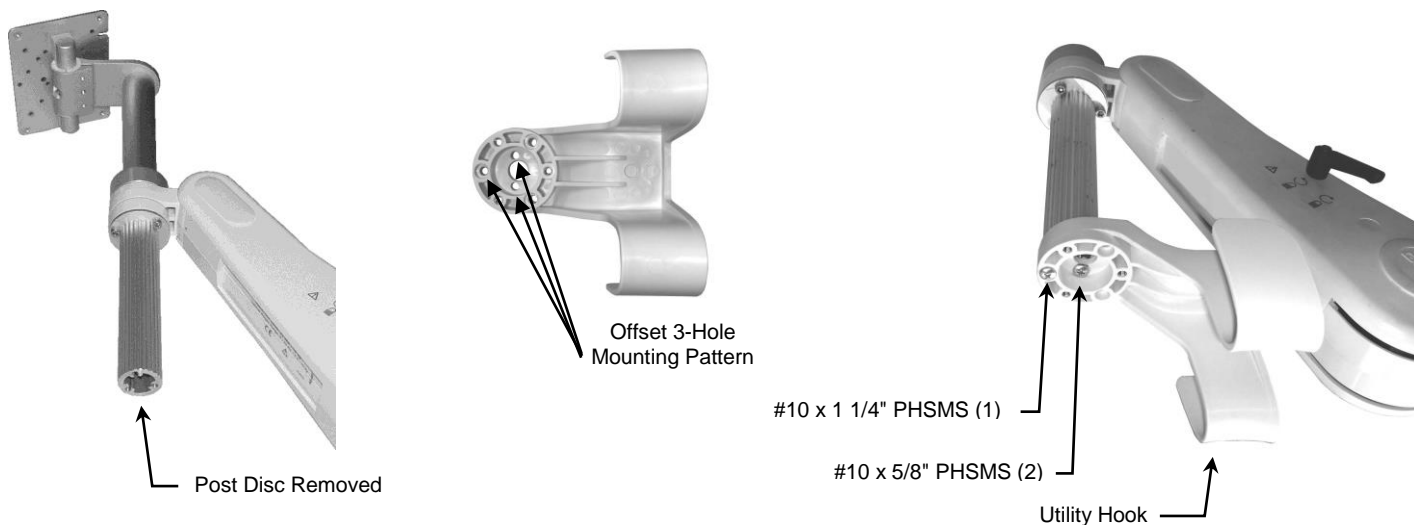

Section 4.0: Counterbalance Adjustment

The VHM Arm must be adjusted to counterbalance the mounted instruments throughout the Arm's vertical range of motion. When properly counterbalanced, the VHM Arm will maintain its height when the Locking Lever is disengaged. Because instrument weights vary, some adjustment is required to achieve optimal performance.

 **Use Caution while performing this procedure. Do not attempt counterbalance adjustment unless the instrument and accessories are mounted on the Arm.**

1. Grasp the Arm behind the mounted instrument(s) to prevent sudden upward motion. Carefully unlock the Arm and move it to a horizontal position that allows access to the Adjuster Cover (below left). Lock Arm in horizontal position.
2. Open the Adjuster Cover by inserting a flat blade screwdriver in the slot at the rear of the Cover and prying upward. If necessary unlock and readjust the Arm until the Counterbalance Adjuster bolt is accessible through the Adjuster Cover (below center). Lock Arm when Counterbalance Adjuster is accessible.
3. With the 1/2" [13mm] socket wrench on the Adjuster, carefully unlock the arm. Turn the Adjuster *counterclockwise* (CCW) to increase counterbalance force, or *clockwise* (CW) to decrease counterbalance force. Counterbalance is correctly adjusted when the mounted instrument can be moved up or down with minimal force and does not rise or fall after releasing the Arm. Close Adjuster Cover.

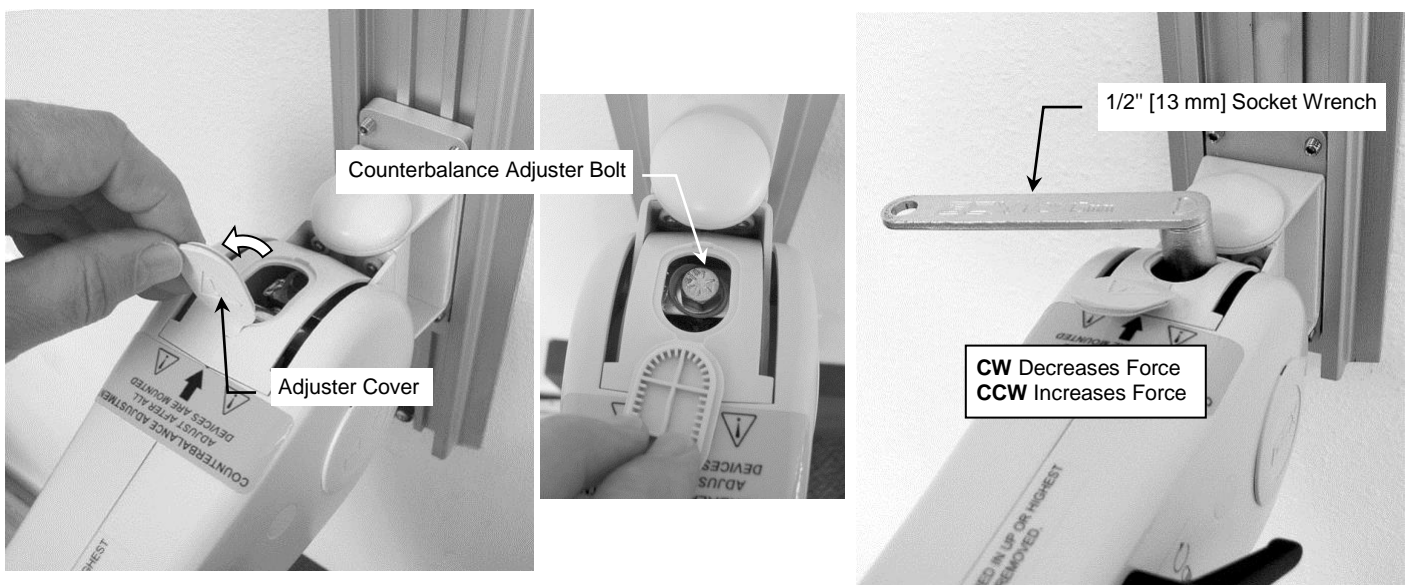

4. Check the pivot, tilt, and swivel functions for proper tension. If adjustments are required, refer to the "VHM Arm Operation & Adjustment" on pages 5 - 6.

Section 5.0: Cable Management

Cable Management

A Cable Guide is provided to facilitate routing of cables along the underside of the arm. Squeeze the Cable Guide until its edges snap into the grooves in the bottom surface of the arm. Leave some extra cable loose at the front and rear of the arm to prevent cable binding, connector damage, or Cable Guide damage.

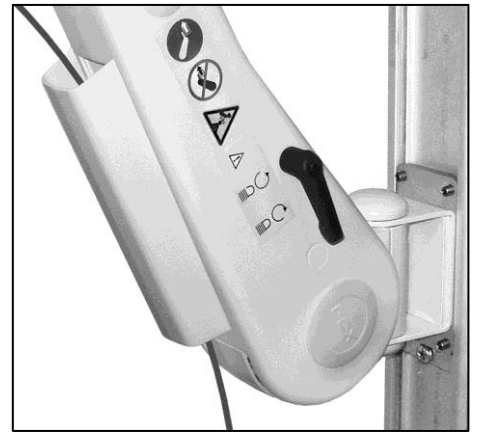
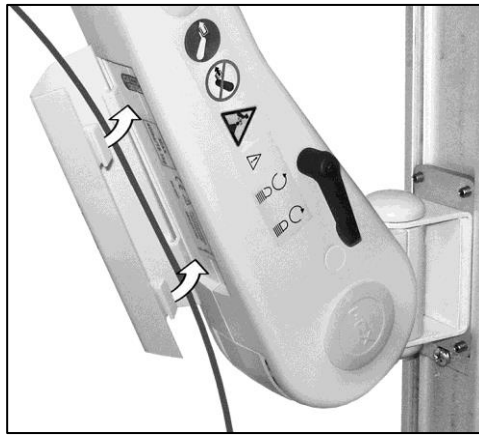
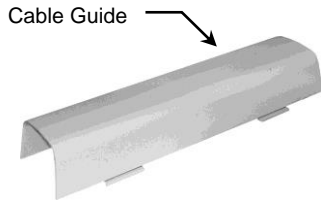

Installing the 16" Wall Channel Cover

Install the Wall Channel Cover in accordance with the *Channel Cover Installation Guide (DU-UT-0001-20)*.