

## Installation Guide

### Single-Wide Module Housing Hanger (Yoke)

The purpose of this guide is to:

1. Describe procedure for attaching Yoke to M-Series Arm or Cross Member (page 2).
2. Describe procedure for mounting module in Yoke (page 3).

### Parts Reference

The following parts and hardware are included with this installation kit (hardware may not be shown):

Item #	Description	Qty
1	Yoke	1
2	#10-32 x 3/8" Socket Head Cap Screw (SHCS)	3
3	Sub Plate (Mounting Adapter)	1
4	#8-32 x 5/8" Pan Head Machine Screw (PHMS)	4
5	#8 Flat Washer	4
6	#8-32 x 1/4" Flat Head Machine Screw (FHMS)	4
7	5/32" Ball-End Hex Wrench	1

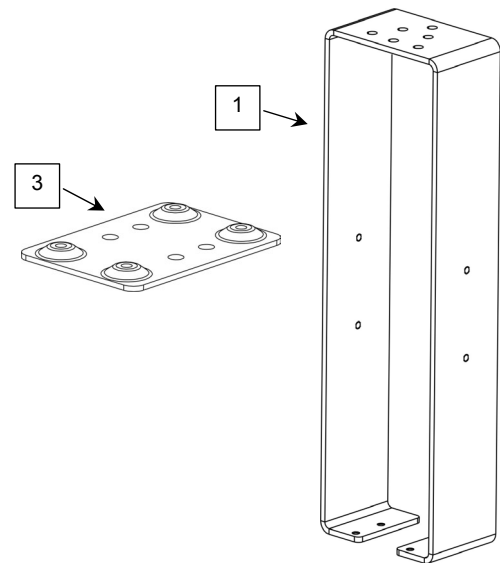

### Tools Required

Phillips screwdriver (not provided), 5/32" hex wrench (provided).

## Attaching Yoke to M-Series Arm or Cross Member

Refer to callouts below.

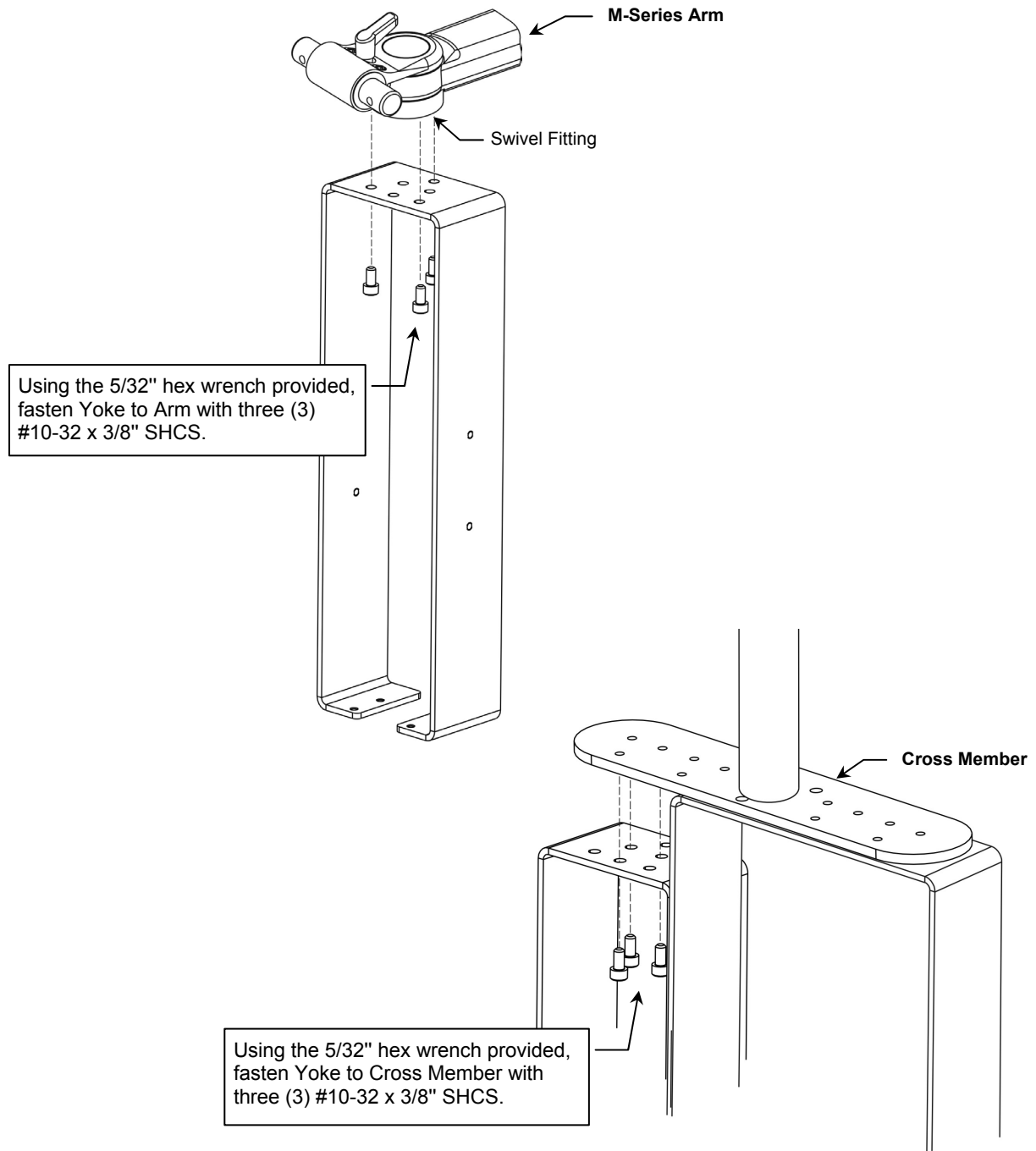

## Mounting Module Housing in Yoke

Follow steps in callouts below.

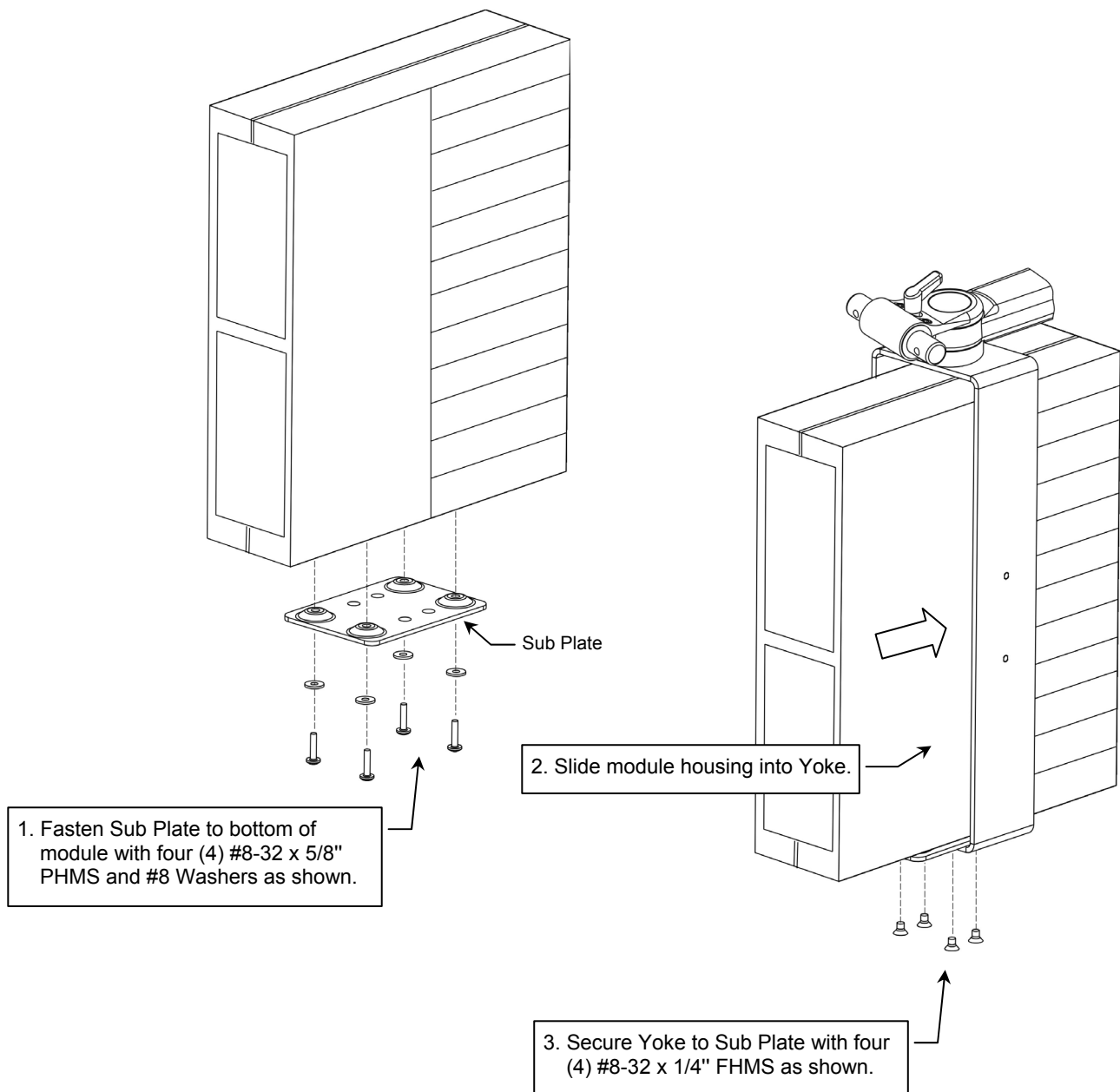

## Periodic Maintenance

Periodically inspect all fasteners associated with the mounting system. Tighten or adjust fasteners as necessary for optimal operation and safety.

## Cleaning the Mounting Assembly

1. The mounting assembly may be cleaned with most mild, non-abrasive solutions commonly used in the hospital environment (e.g. diluted bleach, ammonia, or alcohol solutions).
2. The surface finish will be permanently damaged by strong chemicals and solvents such as acetone or trichloroethylene.
3. Do not use Steel wool or other abrasive material.
4. Damage caused by the use of unapproved substances or processes will not be warranted. It is recommended that you test any cleaning solution on a small area of the mounting assembly that is not visible to verify compatibility.
5. Never submerge or allow liquids to enter the mounting assembly. Wipe any cleaning agents off of the mounting assembly immediately using a water-dampened cloth. Dry the mounting assembly thoroughly after cleaning.

**CAUTION:** GCX makes no claims regarding the efficacy of the listed chemicals or processes as a means for controlling infection. Consult your hospital's infection control officer or epidemiologist. To clean or sterilize mounted devices or accessory equipment, refer to the specific instructions delivered with those products.