

## Installation Guide

### Stack Mount for Philips MP90 CPU and G5

The purpose of this guide is to:

1. Describe attachment of table mount to Stack Mount (page 1).
2. Describe attachment of Stack Mount to MP90 CPU (pages 2 – 3).

#### Parts Reference

The following parts and hardware are included in this installation kit (hardware not shown):

Item #	Description	Qty
1	Stack Mount Assembly	1
2	M6 x 10 mm Flat Head Machine Screw (FHMS)	3
3	M3 x 12mm Pan Head Machine Screw (PHMS)	4
4	Horizontal Mounting Bracket	1

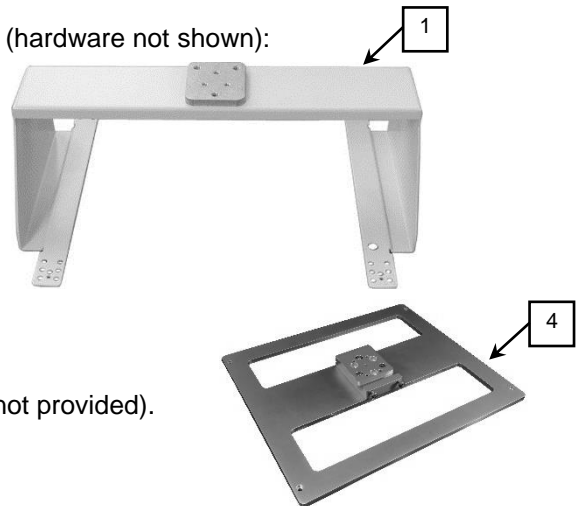

**Tools Required:** Small and medium-tipped Phillips screwdrivers (not provided).

#### Attaching Philips Table Mount to Stack Mount

This procedure requires attachment of a Philips-supplied table mount. The table mount is not included in this installation kit.

1. Fasten table mount to Mounting Adapter with three M6 x 10 mm FHMS as shown below.

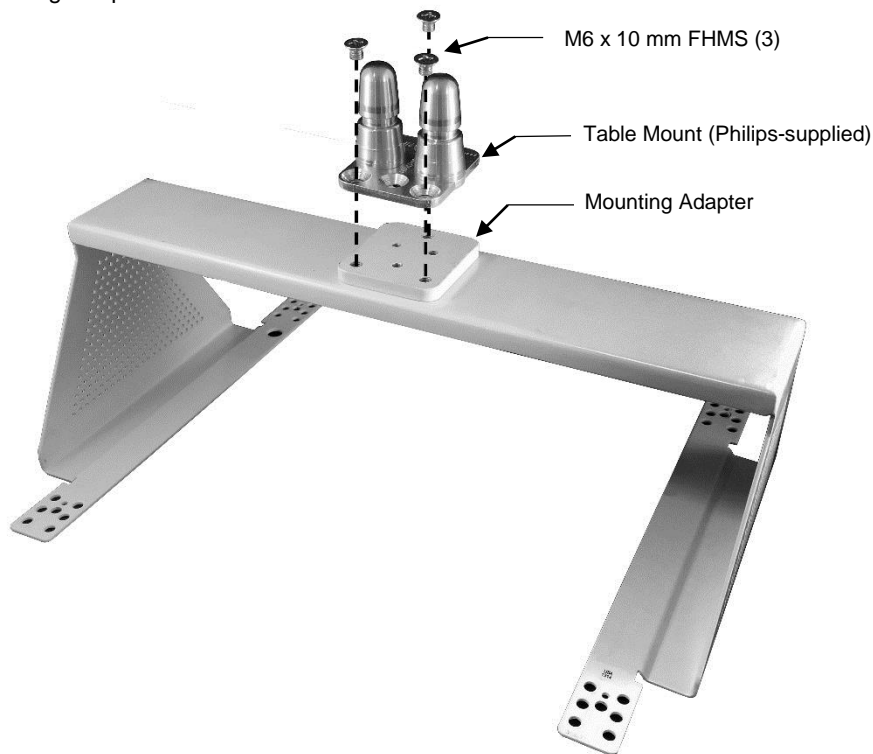

## Attaching Mount to CPU

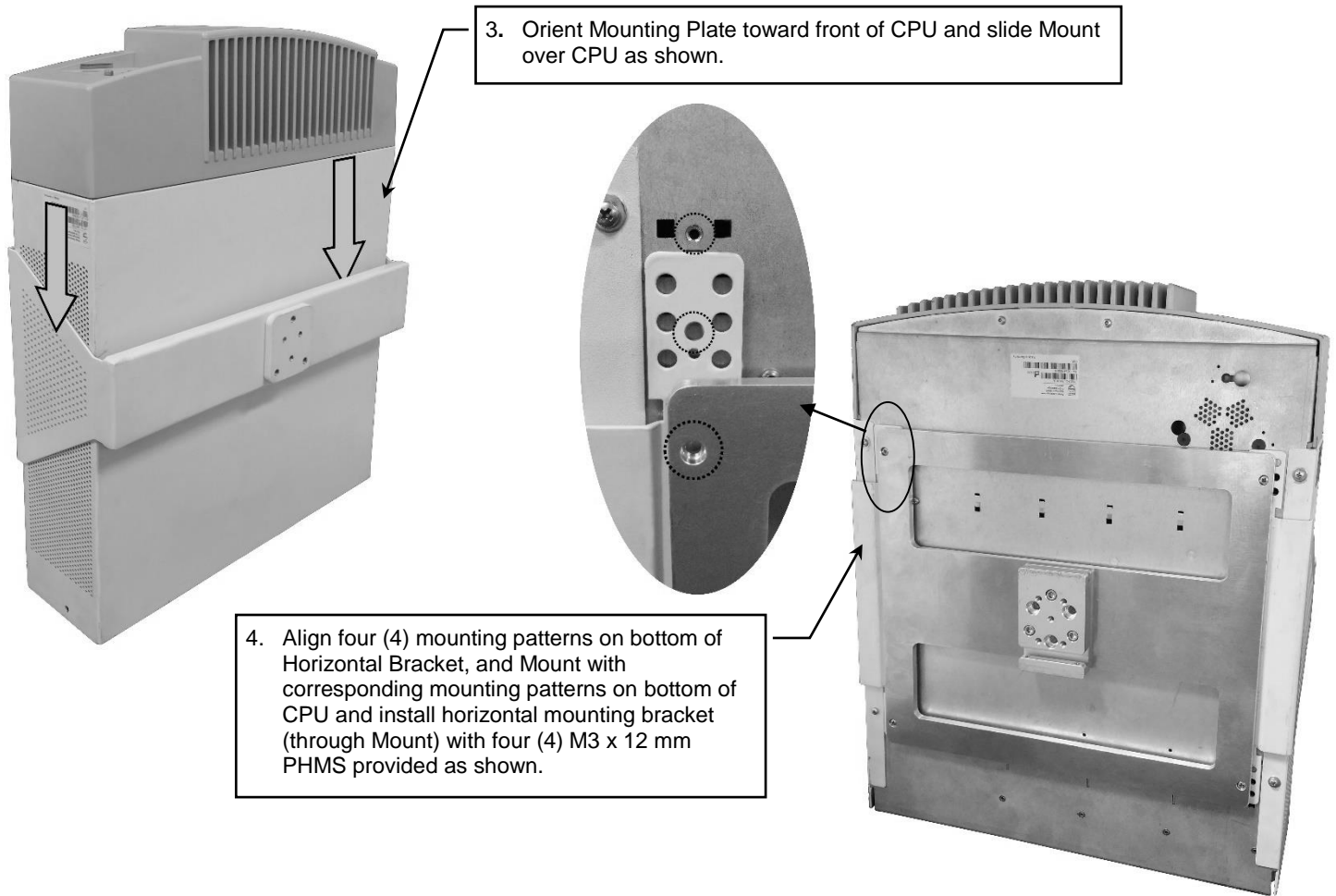
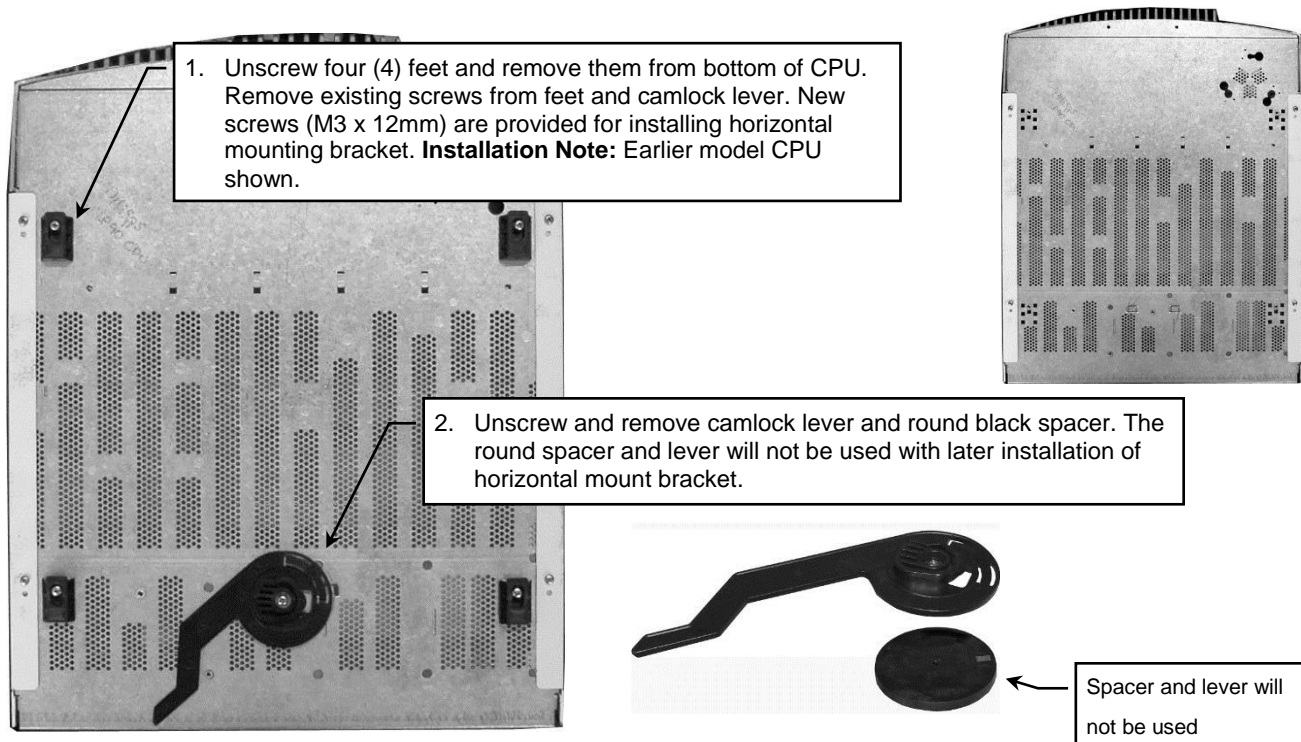

## Attaching Stack Mount to Horizontal Channel



Slide the horizontal adaptor into the horizontal channel and move to desired location.

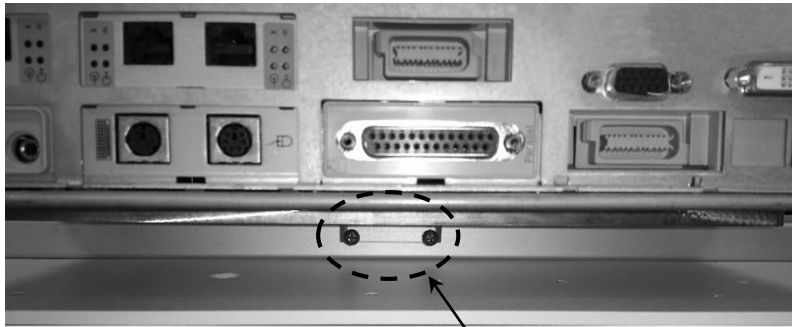

Tighten both (2) 8-32 PHMS when desired position has been reached.

## Mounting G5 on Stack Mount

1. Mount G5 on table mount in accordance with Philips installation instructions. Installation shown below.

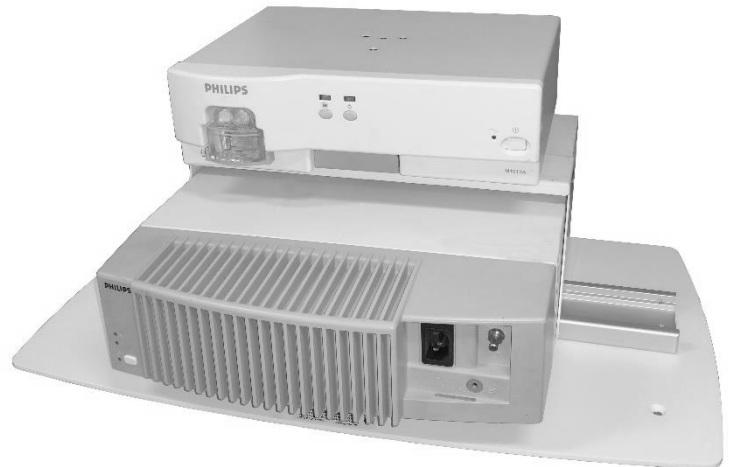
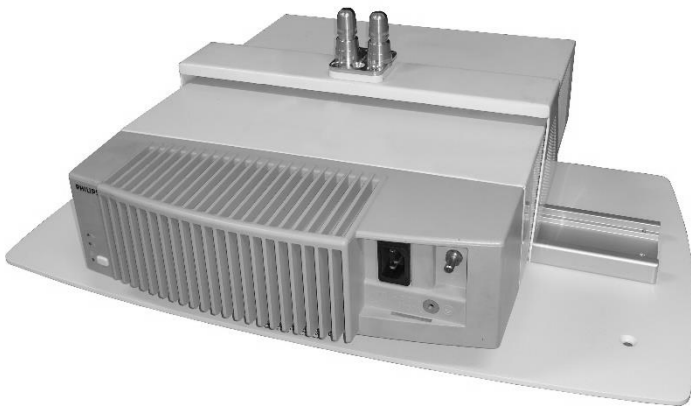

## **Routine Maintenance**

Periodically inspect all hardware associated with the mounting system. Tighten or adjust as necessary for optimal operation and safety.

## **Cleaning the Mounting Assembly**

1. The mounting assembly may be cleaned with most mild, non-abrasive solutions commonly used in the hospital environment (e.g. diluted bleach, ammonia, or alcohol solutions).
2. The surface finish will be permanently damaged by strong chemicals and solvents such as acetone and trichloroethylene.
3. Do not use steel wool or other abrasive material to clean the mounting assembly.
4. Damage caused by the use of unapproved substances or processes will not be covered by warranty. We recommend testing of any cleaning solution on a small area of the arm that is not visible to verify compatibility.
5. Do not submerge or allow liquids to enter the arm. Wipe any cleaning agents off of the arm immediately using a water-dampened cloth. Dry the arm thoroughly after cleaning.

**CAUTION:** GCX makes no claims regarding the efficacy of the listed chemicals or processes as a means for controlling infection. Consult your hospital's infection control officer or epidemiologist. To clean or sterilize mounted instruments or accessory equipment, refer to the specific instructions delivered with those products.