

**Installation Guide**  
**Channel Mount Arm Counterweight Upgrade**

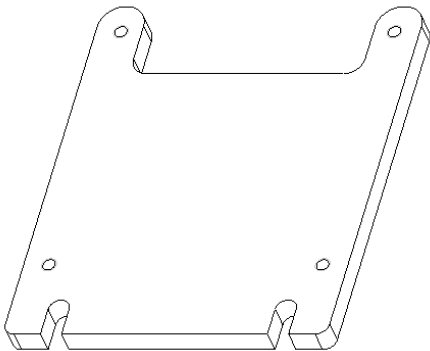

**(1X) Counterweight**



**(1X) 8mm Combination Wrench**

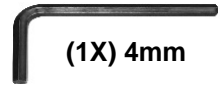

**(1X) 4mm**



**(1X) T10**

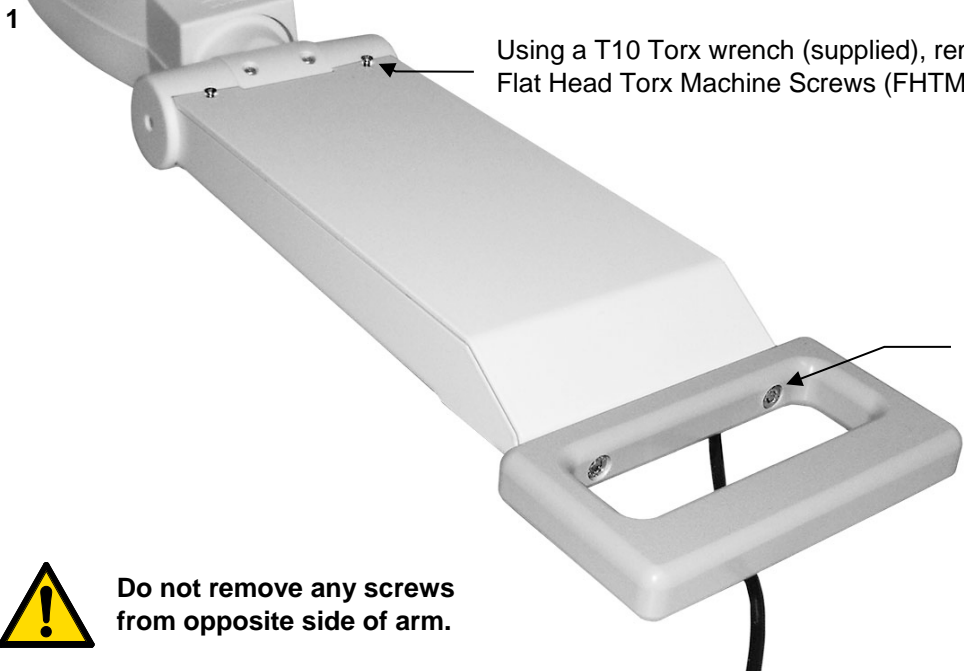

1 Using a T10 Torx wrench (supplied), remove the (2) M3 x 10mm Flat Head Torx Machine Screws (FHTMS) and set aside.

Using the 4mm hex wrench (supplied), loosen the (2) handle screws by approximately 3 complete turns. Remove cover and set aside.



Do not remove any screws from opposite side of arm.

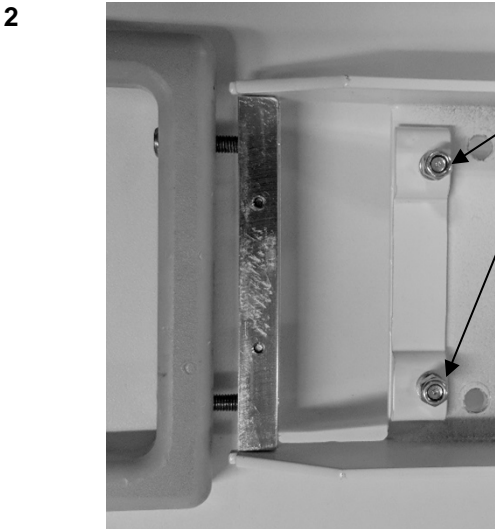
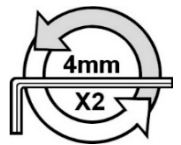
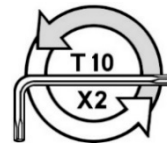

2 Remove (2) nuts, (2) washers and bar. Set aside.

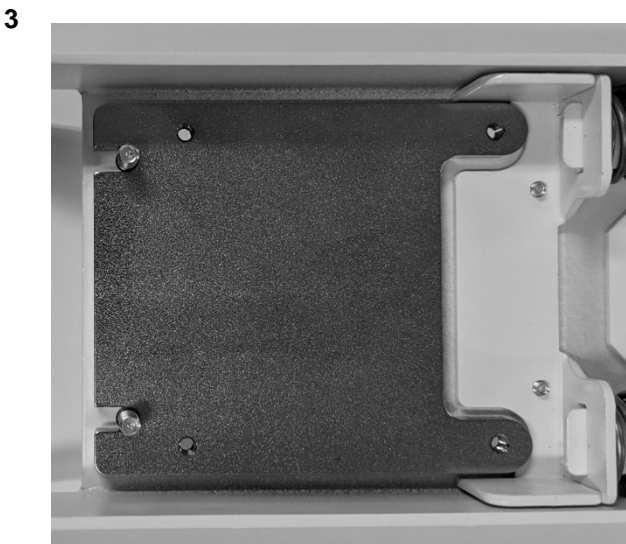
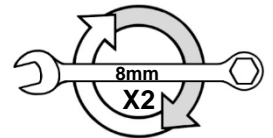

3 Install counterweight as shown. Replace bar, oriented as below.

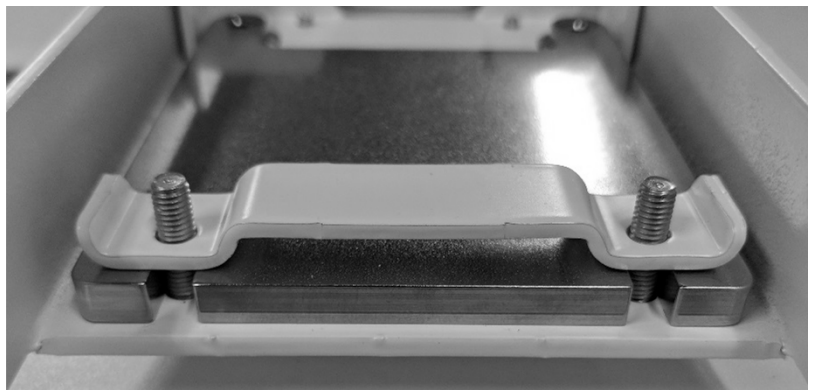

4

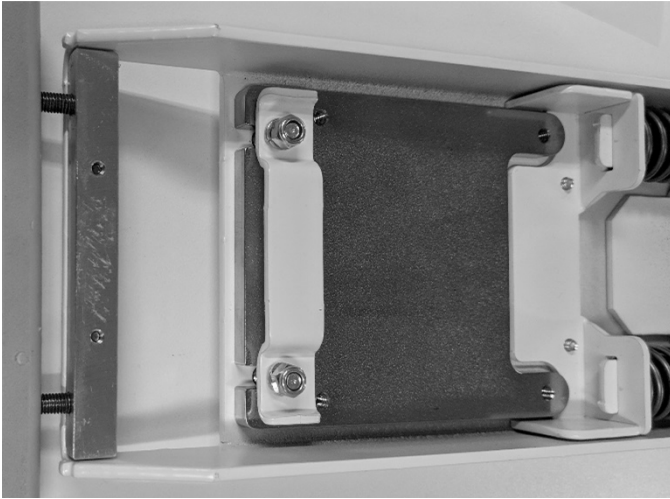

Install (2) washers and (2) nuts. Tighten with wrench.

75mm VESA mount holes are now threaded M4

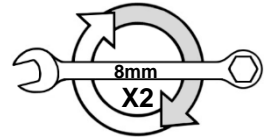
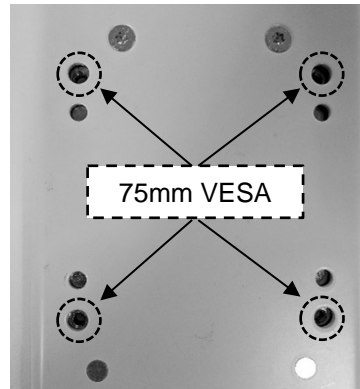

5

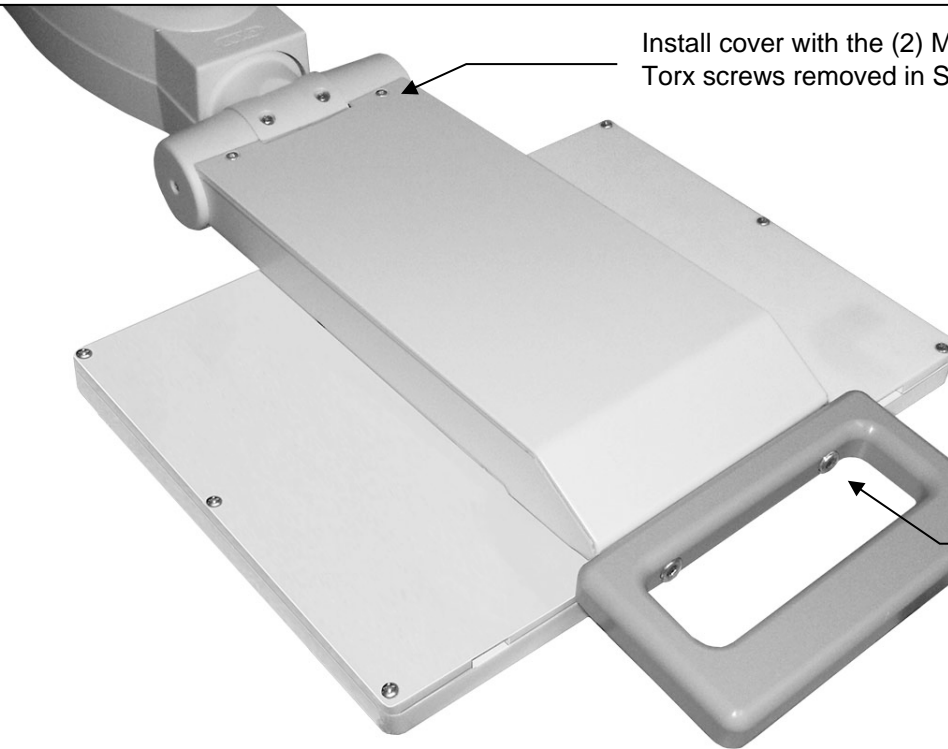

Install cover with the (2) M3 x 10mm Torx screws removed in Step 1.

Tighten the (2) handle screws.

