

VHM™ Variable Height Support Arm For Spacelabs Medical

Ultraview 1700

Description	GCX P/N
VHM for 91415A Flat Panel	SL-0042-12
Power Supply Holster	SL-0037-16
Ultraview 1700 Hanger	SL-0032-88
Dual Power Supply Holster	SL-0037-18



*Model 1050**

Description	GCX P/N
VHM for 1050	SL-0019-12
Power Supply Holster (119-0251-00)	SL-0031-17



VHM Features:

- Smooth variable height adjustment to accommodate clinician needs
- Vertical and lateral movement combined with independent tilt and swivel adjustment at the head of the arm permits optimal positioning of equipment
- Parallel linkage provides consistent viewing angle at any arm position
- Compatible with standard GCX wall channels
- 30 pound (13.6 Kg) Max. duty rating, counterbalanced via an adjustable internal gas spring
- +/- 60 degrees vertical motion range (17" (43.18 cm) total travel)
- +/- 90 degrees lateral motion range (from perpendicular to wall)
- Vertical position lock via locking lever
- Integrated cable management track
- Rugged, durable construction assures reliable operation

GCX® offers a complete range of mounting solutions. Please contact us or visit our web site for additional information.

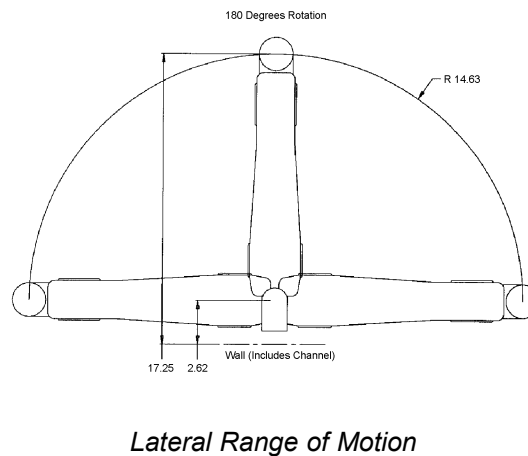
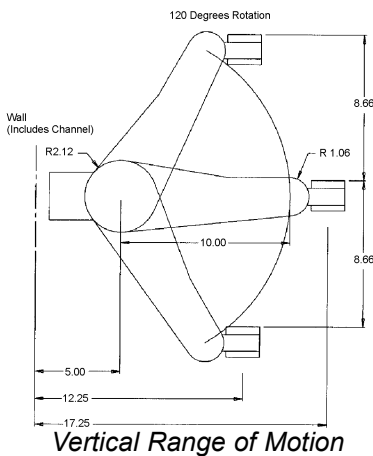

GCX CORPORATION
 3875 Cypress Drive
 Petaluma, CA 94954-5635
 707.773.1100
 800.228.2555 US/CAN
 Fax 707.773.1180
 www.gcx.com

GCX is an ISO9001 registered company.

3/01-2

