

M Series - 12" Pivot Arm

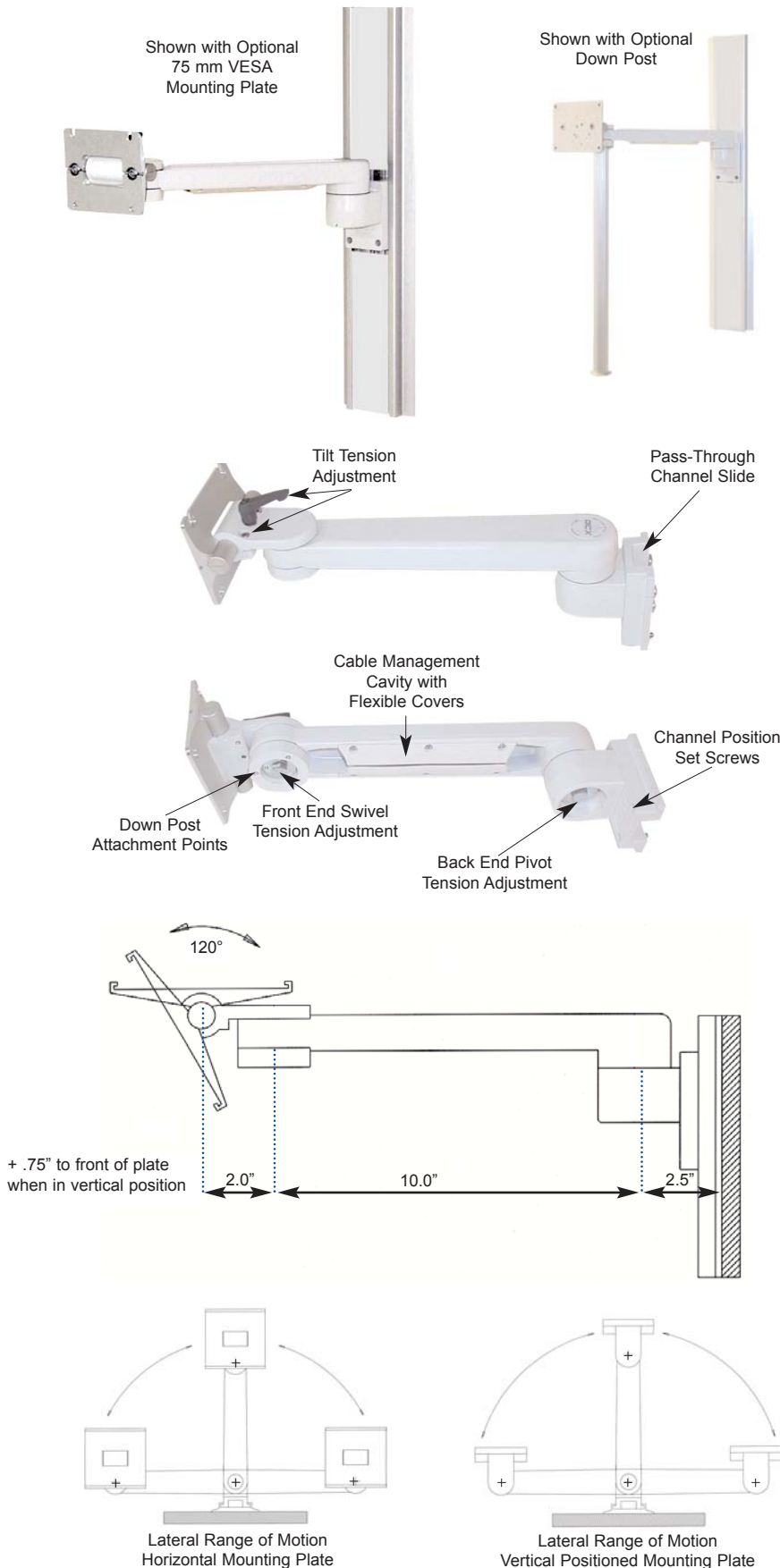

12" Pivot Arm

The M-Series arm provides many performance and aesthetic enhancements including:

- 12" (30.5 cm) arm length
- Pivot at the slide for lateral adjustability
- 180° nominal lateral pivot range¹
- Smooth tilt and swivel adjustments at the front end
- 60 lbs. (27.2 kg) Arm / 30 lbs. (13.6 kg) Tilt duty ratings²
- Cable management:
 - Cavity in the bottom of the arm with flexible covers
 - Pass-through channel slide
- Includes channel cover
- Powder coat durable paint finish
- Integrated channel position set screws
- Optional integrated down post or hanger attachments with keyed or independent swivel
- Accommodates rear and bottom mounted devices
- Wall channel lengths³ vary from 7" (17.8 cm) to 55" (139.7 cm)

¹ Arm length and/or device size may limit lateral pivot range

² Based on GCX Manual Tilt front-end mounting option

³ Sold separately or as part of complete kits with Channel Cover

GCX® offers a complete range of mounting solutions. Please contact us or visit www.gcx.com for additional information.



3875 Cypress Drive
 Petaluma, CA 94954-5635
 707.773.1100
 800.228.2555 US/CAN
 Fax: 707.773.1180
 E-mail: sales@gcx.com
www.gcx.com

GCX is an ISO9001 registered company.



GCX, PolyMount and PolyQuip are registered trademarks of GCX Corporation.

© Copyright 2003

7/03-4