

Installation Guide

Folding Keyboard Bracket – Flush Wall Mount

The purpose of this guide is to:

1. Describe mounting of Folding Keyboard Bracket in wall channel.
2. Describe attachment of typical keyboard tray to the Folding Keyboard Bracket.
3. Describe adjustment of folding tension.

Parts Reference

The following parts and hardware are included in this installation kit (hardware not shown):

Item #	Description	Qty
1	Folding Keyboard Bracket	1
2	1/8" Hex Wrench	1



Tools Required: 1/8" hex key (provided), Phillips screwdriver.

Mounting the Folding Keyboard Bracket

1. Slide the Folding Keyboard Bracket into the Channel and move to desired mounting position. Using the 1/8" hex key provided, tighten the two (2) socket set screws at bottom of Slide.

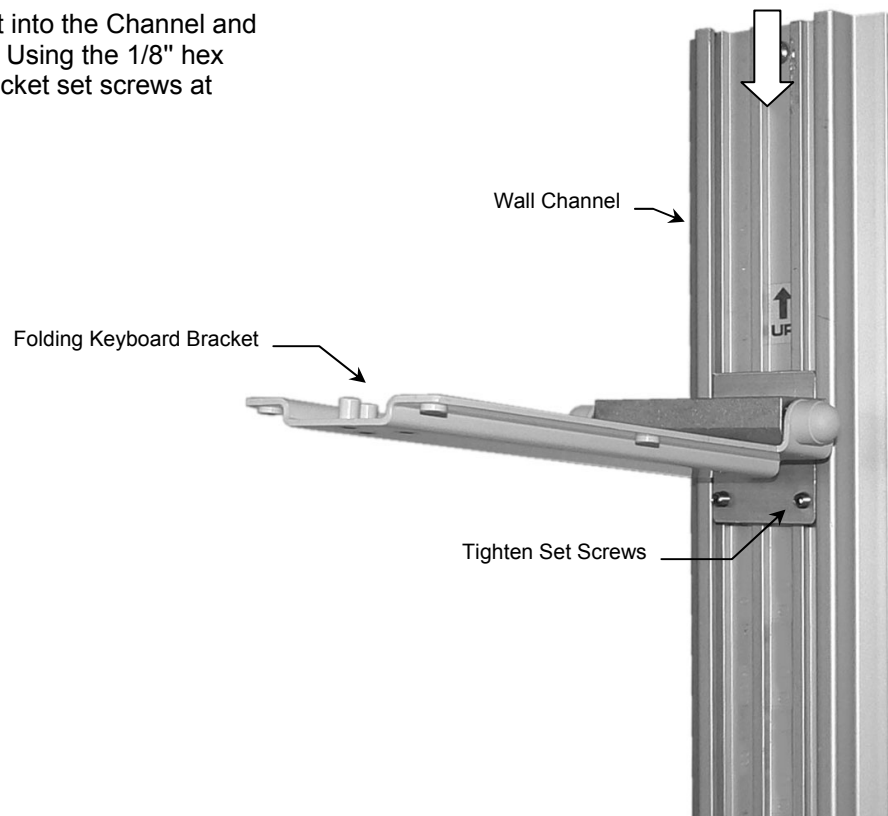

Attachment of Typical Keyboard Tray or Plate to Folding Keyboard Bracket

Installation Note: Hardware for attaching Keyboard Tray or Plate to Keyboard Bracket is supplied with the Tray or Plate.

1. Align mounting pattern on Keyboard Tray or Plate with corresponding threaded holes in Folding Bracket. Fasten Tray/Plate to Bracket with #10-32 flat head machine screws (FHMS). **Installation Note:** If Keyboard Tray is equipped with mouse trays, it may be necessary to slide both left and right mouse trays outward a few inches before attaching Tray to Bracket.

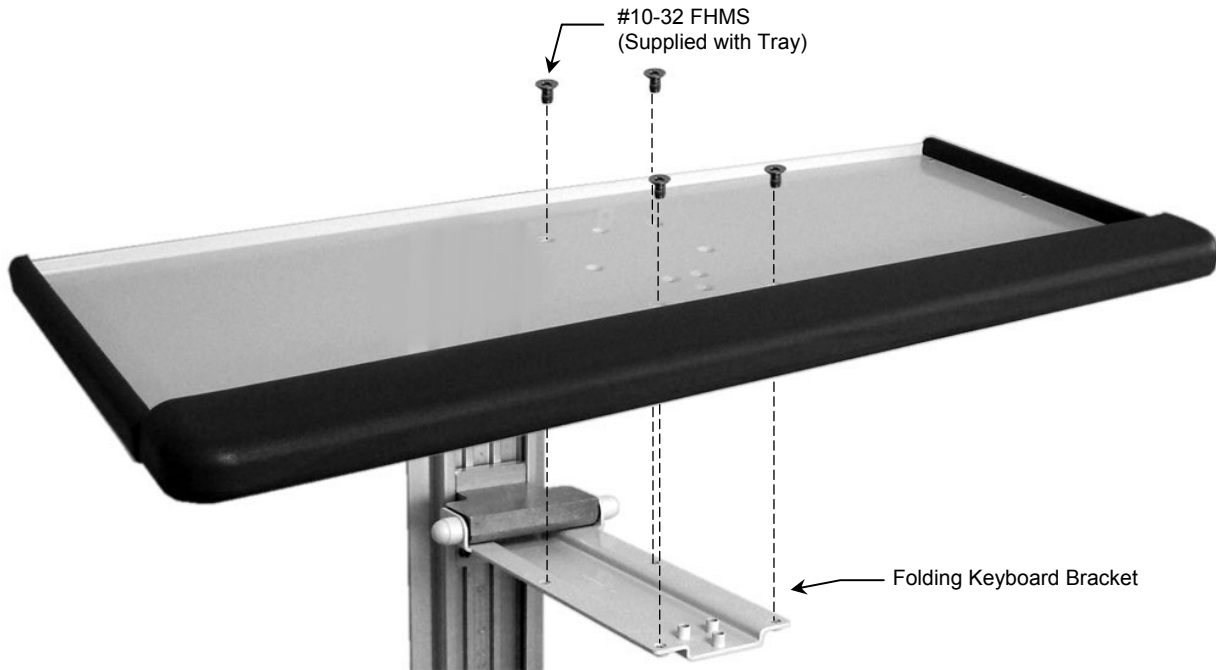

Wall-Mounted Folding Keyboard Bracket
(Keyboard Tray Mounted)



Adjusting Folding Tension

If the Folding Keyboard Bracket becomes difficult to fold or will not maintain the folded (upward) position, adjust folding tension as described below:

1. Pry plastic bolt covers off each end of the hinge bolt.
2. Using a 1/2" wrench on each end of the bolt, tighten or loosen bolt until desired tension is achieved.
3. Replace bolt covers.

